



WELD THE WORLD

# MicroMag 302 MFK



# MicroMag 302 MFK

Multi Process Portable Synergic



## 302 MFK: Applications

- Thanks to its dimensions and the ratio weight/ power duty/ cycle 302, MFK is the best option on the market, for small and medium workshops, ideal for table welding and car body repair.
- Easy to transport, only 22 kg, it is the best option for maintenance and repair on field, shipyard and off-shore operations.
- MicroMag 302 MFK is designed for welders at all levels and it is ideal machine for colleges and welding schools.



## Remote Controls

- Connector with insulated pins for remote control of welding parameters.
- Torches with potentiometers and up/down switches can be used as well



## 302 MFK: Wire Feeder

- Solid metallic 4 rolls motor drive-system for any type of wire.
- Wire diameters from 0,6 to 1,2mm.
- Wire speed from 2 to 20 meters per minute.
- Wire spools till 300 mm /15 kg.

## Integrated phases control

- Net's phases detector led.



## Innovative System to clean the machine without opening the external structure body



Ventilation grids and ventilators removable to allow an easy cleaning of the heat sink, by means of compressed air.

# MicroMag 302 MFK

Multi Process Portable Synergic



W.eco Technology Inside

- This symbol highlights Weco's constant care for ecological issues and new technologies which have been introduced to reduce the environmental impact.
- MicroMag 302MFK introduce new technological solutions in order to reduce the harmonic current emissions according to the future International Standards, to increase even more the power inverter efficiency.
- The same welding deposit is achieved with less electrical power, less total power and less CO2 emission for the safety of Planet Earth.

## Easy setting of welding parameters

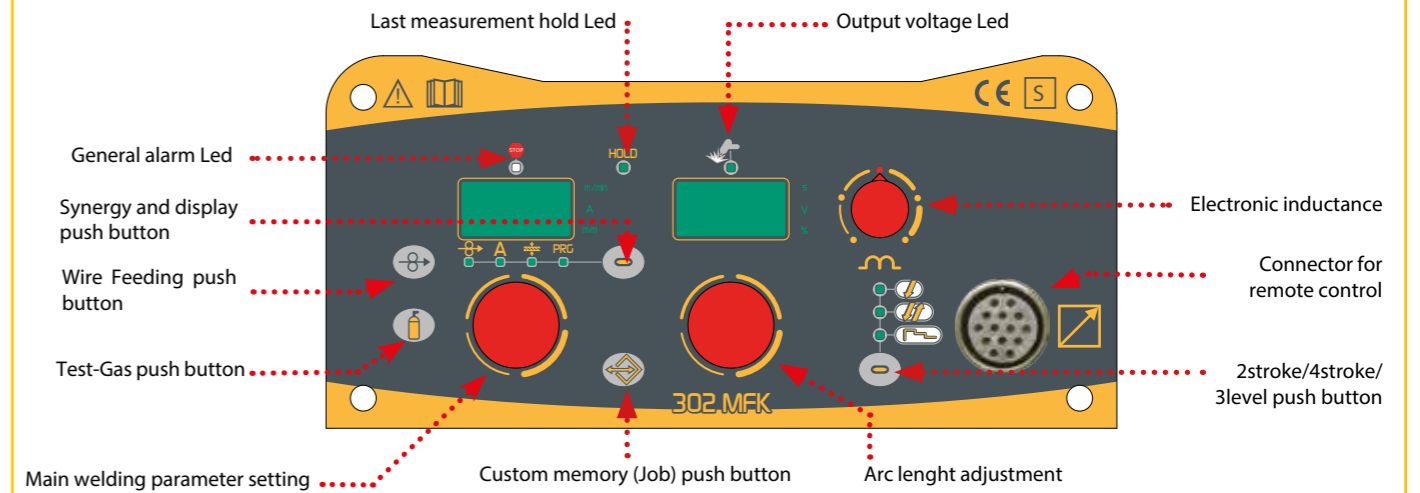

## Easy selection of synergic welding curves



Set desired Synergic Curve

Select main welding parameter

Adjust main welding parameter

Welding!



# MicroMag 302 MFK

Multi Process Portable Synergic



## Digital Intelligence Inside

- Power source functions self-check in real time.
- Synergic programs for many applications available.
- Customized welding parameters.
- Welding operations can be replicated in time.
- A top quality instrument in certified welding procedures.



## Digital Inductance

- Allows you to optimize arc dynamic in any welding condition.
- Step-less regulation.
- Precise and complete synergic settings.



**BURN BACK:**  
An optimal wire cutting at the end of welding helps perfect starts.



**SOFT START:**  
Approaching speed of wire and welding dynamics are totally synergic giving low spattering at start, in any type of material.

**SPOT WELDING:**  
Dedicated controls, low spattering and high execution-speed allow you to get perfect welding spots.

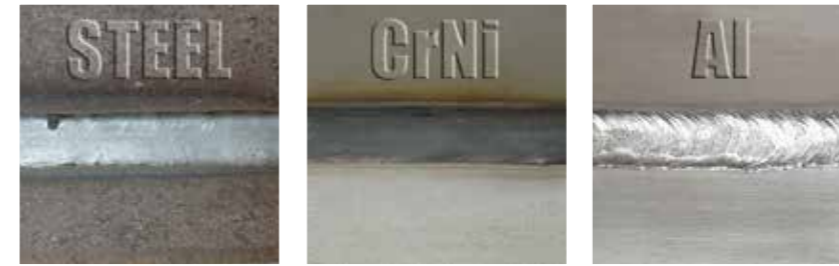

## HAC (Hybrid Arc Control) Flawless Welding Arc

- Soft and very stable welding arc.
- Low heat input both in Short and Spray Arc.
- Small Globular arc range. Welding is always perfect.
- Low spattering even with a high level of CO<sub>2</sub> mixed gas
- Quality of weld beams is just like the one you have in pulsed welding.
- Inductance and start/finish parameters are optimized in the synergic setting.
- Recommended for special applications like welding on Laser cut sheets without reworking, fillet welds on thin sheets with small deformations, and low residual stress. Accurate when you need to weld plates with relevant gaps...

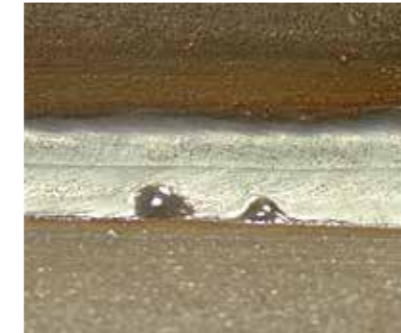

**SPRAY ARC:** HAC allows you to have a short spray arc with better penetration of the root, lower heat input and higher welding speed with no edge cutting and spattering.



**WELDING POSITION:** HAC gives an optimal fusion of the bead's edges in short arc welding and to make overhead and vertical up position welding easier.



**PG POSITION:**  
HAC allows thin plates welding in vertical down position with gap up to 5mm wide.



**THIN PLATES:**  
HAC gives smooth and controlled short arc at lower parameters too. Low spattering, good edge wetting, low heating and small deformation are achieved in thin plate welding.

## Real Synergic Welding (all you need is a knob!)

- 35 synergic programs.
- Optimized programs for Flux Core Wires and high Performance Wires.
- Optimal welding results for welders at all levels.
- Second level menu available for experts.

Synergic programs					
Wire Diameter	0,8	1,0	1,2	1,4	
Display	on the right				on the left
Manual Welding	P0				nPr
SG2/SG3 (80%Ar-20%CO <sub>2</sub> )	P1	P2	P3	--	FE
SG2/SG3 (92%Ar-8%CO <sub>2</sub> )	P4	P5	P6	--	FE
SG2/SG3 (100%CO <sub>2</sub> )	P7	P8	P9	--	FE
INOX 308 (98%Ar-2%CO <sub>2</sub> )	P10	P11	P12	--	S.S.
INOX 316 (98%Ar-2%CO <sub>2</sub> )	P13	P14	P15	--	S.S.
AlMg5 (100%Ar)	--	P17	P18	--	AL
AlSi5 (100%Ar)	--	P20	P21	--	AL
CuSi3 (100%Ar)	P22	P23	--	--	CU.S
CuAl8 (100%Ar)	--	--	--	--	CU.A
RFCW (80%Ar-20%CO <sub>2</sub> )	--	--	P28	P29	rFC
BFCW (80%Ar-20%CO <sub>2</sub> )	--	--	P30	P31	bFC
MFCW (80%Ar-20%CO <sub>2</sub> )	--	--	P32	P33	mFC
Free Programs	P34				nPr



Display, Led and Knob for Synergic programs setting.

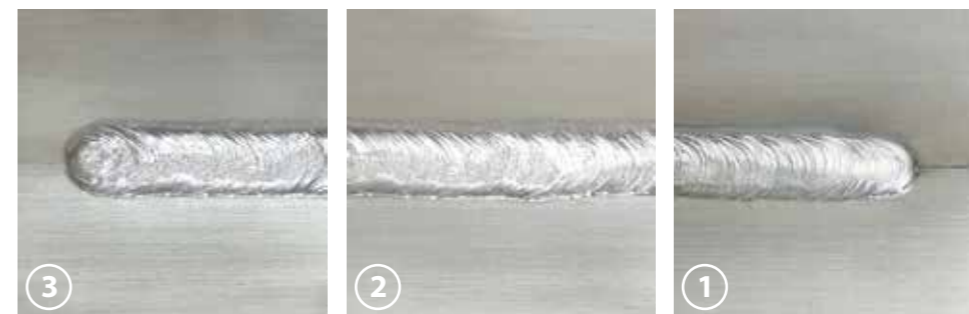

**LEVEL 3:** A low current ends the welding optimally by filling the crater on weld beads.

**LEVEL 2:** The welding current is optimized with the plate thickness and the requested weld.

**LEVEL 1:** A correct initial current gives optimal penetration from welding start.



**3T SPECIAL:** Allows you to set and recall 3 different current levels by pushing the trigger switch in order to achieve top quality weld beads: Highly recommended for Aluminum welding.



# MicroMag 302 MFK

Multi Process Portable Synergic

# MicroMag 302 MFK

Multi Process Portable Synergic



## MMA

Up to 5 mm electrodes in MMA Adjustable Arc Force and Hot Start



## MIG MAG

MIG MAG welding system allows High productivity and flexibility



## TIG DC LIFT





Lift Tig ignition to reduce tungsten inclusions



## APPLICATION FIELD



- Industrial assembly
- Maintenance and servicing
- Naval shipbuilding industry
- Used in car-body shops
- Electro-mechanical assembly
- Agricultural machine servicing
- Air conditioning plants
- Hydraulics
- Pipe welding
- Window and door frames
- Fabrication
- Schools & Colleges

MicroMag 302 MFK									
	3x400Vac ± 15% @ 50-60Hz								
	16A								
	MIG-MAG			TIG - WIG			MMA		
% <sub>40°C</sub>	35%	60%	100%	50%	60%	100%	40%	60%	100%
-I <sub>2</sub>	300A	230A	200A	250A	240A	210A	250A	220A	190A
% <sub>RT</sub>	-	60%	100%	-	-	100%	-	-	100%
-I <sub>2</sub>	-	300A	250A	-	-	250A	-	-	250A
I <sub>2</sub>	5A - 300A			5A - 250A			5A - 250A		
U <sub>0</sub>	11/60V								
P <sub>T MAX</sub>	10,3KVA -9,7KW								
IP	23S								
	560 x 280 x 390mm								
	21,0Kg								



EN60974-1/10  
EN60974-1/12



Distributor:

WECO srl  
Corso Noblesville n.8,  
35013, Cittadella, (Padova) Italy  
+39 049 7301120  
www.weco.it