



WELD THE WORLD

WF-204

WF-205



Instruction manual

ENGLISH

Translation of original instructions





INDEX



1	INTRODUCTION.....	6
1.1	PRESENTATION.....	7
2	INSTALLATION AND ASSEMBLY	8
2.1	CONNECTIONS AND SOCKETS.....	8
2.2	MIG/MAG INSTALLATION.....	10
2.3	POSITIONING THE SPOOL AND THE WIRE IN THE WIRE FEEDER.....	12
2.4	PREPARING FOR MMA WELDING.....	14
2.5	PREPARING FOR TIG WELDING.....	15
3	USER INTERFACE.....	16
3.1	MAIN SCREEN.....	17
3.2	SETTING UP THE WELDING PARAMETERS.....	18
4	PRELIMINARY SETTINGS.....	21
4.1	SETTING THE LANGUAGE.....	21
4.2	FIRMWARE UPGRADE.....	22
4.3	SETTING THE DATE AND TIME.....	25
4.3.1	SETTING THE TIME ZONE.....	26
4.3.2	SETTING THE DATE.....	27
4.3.3	SETTING THE TIME.....	28
4.4	SETTING UP THE WELDER.....	29
4.4.1	SETTING UP THE WIRE FEED.....	30
4.4.2	WIRE FEEDER SETUP.....	31
4.4.3	COOLING UNIT SETUP.....	32
4.4.4	DISPLAY SETUP.....	33
4.4.5	PUSHPULL SETUP.....	35
4.4.6	ROBOT INTERFACE SETUP.....	36
4.4.7	LOCK (LOCK/UNLOCK THE CHANGES).....	39
4.4.8	IMPORT / EXPORT.....	42
4.4.9	WIRE FEEDER SET UP.....	44
4.4.10	SETTING UP THE GUARD LIMITS.....	45
4.4.11	DOCUMENTATION.....	48
5	MIG/MAG WELDING.....	50
5.1	WELDING CIRCUIT CALIBRATION.....	50
5.2	GAS FLOW REGULATION.....	52
5.2.1	VERSION WITHOUT FLOWMETER.....	52
5.2.2	VERSION WITH FLOWMETER.....	53
5.3	TORCH LOADING.....	55
5.4	SETTING UP THE WELDING PARAMETERS.....	56
5.4.1	MIG/MAG WELDING PROCESSES.....	58
5.4.2	MIG/MAG WELDING FUNCTIONS.....	59
5.5	SETTING UP THE MIG/MAG TORCH TRIGGER MODE.....	60
5.5.1	PROCESS PARAMETERS WITH TORCH TRIGGER IN 2 STROKE AND 4 STROKE MODE.....	62
5.5.2	PROCESS PARAMETERS WITH TORCH TRIGGER IN CRATER 2 STROKE MODE.....	62
5.5.3	PROCESS PARAMETERS WITH TORCH TRIGGER IN CRATER 4 STROKE MODE.....	64
5.5.4	MIG/MAG 2S OPERATION.....	66
5.5.5	MIG/MAG 2S SPOT OPERATION.....	67
5.5.6	MIG/MAG 4S OPERATION.....	68
5.5.7	MIG/MAG 4S B-LEVEL OPERATION.....	69
5.5.8	MMIG/MAG CRATER 2S OPERATION.....	70

ENGLISH

5.5.9	MMIG/MAG CRATER 2S OPERATION	71
5.5.10	MMIG/MAG CRATER 4S OPERATION	72
5.5.11	MIG/MAG CRATER 4S B-LEVEL OPERATION.....	73
6	PARAMETERS SETTING.....	74
6.1	SETTING THE PROCESS PARAMETERS	75
6.2	SETTING THE DOUBLE PULSE PARAMETERS	77
6.2.1	DOUBLE PULSE PARAMETERS	79
6.2.2	POWER MIX PARAMETERS.....	80
6.3	SETTING THE JOB SELECTION	81
6.4	SETTING THE B-LEVEL.....	82
6.5	SETTING THE SPOT/PAUSE FUNCTION	84
6.6	K DEEP PROCEDURE SETUP	86
6.7	SETTING DSI (Digital Sense Ignition) PROCEDURE	88
7	MMA WELDING.....	90
7.1	SETTING THE MMA PROCESS.....	90
7.2	SETTING THE PROCESS PARAMETERS	91
7.2.1	MMA PARAMETERS (PARAMETRESMENU).....	92
7.2.2	MMA PARAMETERS (MAIN SCREEN).....	93
8	ARC AIR WELDING	94
8.1	SETTING THE ARC AIR PROCESS.....	94
8.2	SETTING THE PROCESS PARAMETERS	94
9	TIG LIFT WELDING.....	96
9.1	SETTING THE TIG LIFT PROCESS.....	96
9.2	SETTING UP THE TIG TORCH TRIGGER MODE.....	97
9.2.1	PROCESS PARAMETERS WITH TORCH TRIGGER IN 2 STROKE AND 4 STROKE MODE.....	99
9.2.2	TIG LIFT 2T OPERATION.....	99
9.2.3	TIG LIFT 4T OPERATION.....	100
10	JOBS MANAGEMENT	101
10.1	CREATING A JOB.....	101
10.1.1	KEYBOARD FUNCTIONS	102
10.1.2	NAMING A JOB.....	102
10.2	RENAMING A JOB.....	103
10.3	LOADING A JOB	104
10.4	DELETING A JOB	104
10.5	EXPORTING JOBS.....	105
10.6	IMPORTING JOBS.....	106
10.7	ADDING JOBS.....	108
11	SETTING THE FAVOURITE KEY	109
12	RESET	111
12.1	RESET PARAMETERS.....	111
12.2	RESET PARAMETERS AND JOBS	112
12.3	RESET DISPLAY SETTINGS	114
12.4	FACTORY SETTINGS	115
13	ALARM MANAGEMENT	117
14	SYSTEM INFO.....	123
15	WELDING LOG	126
16	SERVICE	129

17	TECHNICAL DATA	130
17.1	WF-204 TECHNICAL DATA	130
17.2	WF-205 TECHNICAL DATA	131
18	WIRING DIAGRAM.....	132
18.1	WF-204 WIRING DIAGRAM	132
18.2	WF-205 WIRING DIAGRAM	133
18.3	CABLE HARNESS: GENERATOR - WIRE FEEDER	134
18.4	REMOTE CONTROL CONNECTOR	135
19	SPARES.....	137
19.1	WF-204	137
19.2	WF-205	139
19.3	WIRE FEEDER MOTOR.....	141
19.4	WIRE FEED ROLLERS	143

1 INTRODUCTION

 	<h3>IMPORTANT!</h3> <p><i>This handbook must be handed over to the user prior to installation and commissioning of the unit. Read the "General prescriptions for use" handbook supplied separately from this manual before installing and commissioning the unit.</i></p> <p><i>The meaning of the symbols in this manual and the associated precautionary information are given in the "General prescriptions for use".</i></p> <p><i>If the "General prescriptions for use" are not present, it is mandatory to request a replacement copy from the manufacturer or from your dealer.</i></p> <p><i>Retain these documents for future consultation.</i></p>
---	--

KEY

	<h3>DANGER!</h3> <p><i>This pictogram warns of danger of death or serious injury.</i></p>
--	--

	<h3>WARNING!</h3> <p><i>This pictogram warns of a risk of injury or damage to property.</i></p>
--	--

	<h3>CAUTION!</h3> <p><i>This pictogram warns of a potentially hazardous situation.</i></p>
--	---

	<h3>INFORMATION!</h3> <p><i>This pictogram gives important information concerning the execution of the relevant operations.</i></p>
--	--

NOTE

The figures in this manual are simply provided to depict the operations and may contain differences with respect to the actual equipment to which they refer.

1.1 PRESENTATION

The **WF-205** has been designed to provide welders with a light welder (weighing only 11.5 kg) which, thanks to its reduced footprint, can be easily moved anywhere, including hard-to-reach places. Moving the welder is also made easier by its ergonomic top handle, which ensures a balanced grip.

The cables are safely and securely fastened in order to protect the signal cable and the power cable, thus prolonging the life of the extension cable. The welder can communicate with the generator up to a distance of 50 metres.

The welding shield protects the user from welding spatter and prevents the grinding sparks from damaging the front panel. The LED lights in the wire feeder compartment make it easier to insert and change the rollers even in poorly lit locations.

The spool storage compartment is fitted with an inspection window to enable the welder to monitor the amount of wire left in the spool.

The 4 drive roller system (optional) ensures a smooth wire unwinding operation, particularly with special wires (Aluminium, Stainless Steel, CuSi, ...). The four roller, wire feeder motor with optical Encoder ensures a more effective and accurate wire feeding operation.

The USB port allows:

- The generator to be fully updated
- The JOBS to be saved and transferred from one generator to another

2 INSTALLATION AND ASSEMBLY

2.1 CONNECTIONS AND SOCKETS

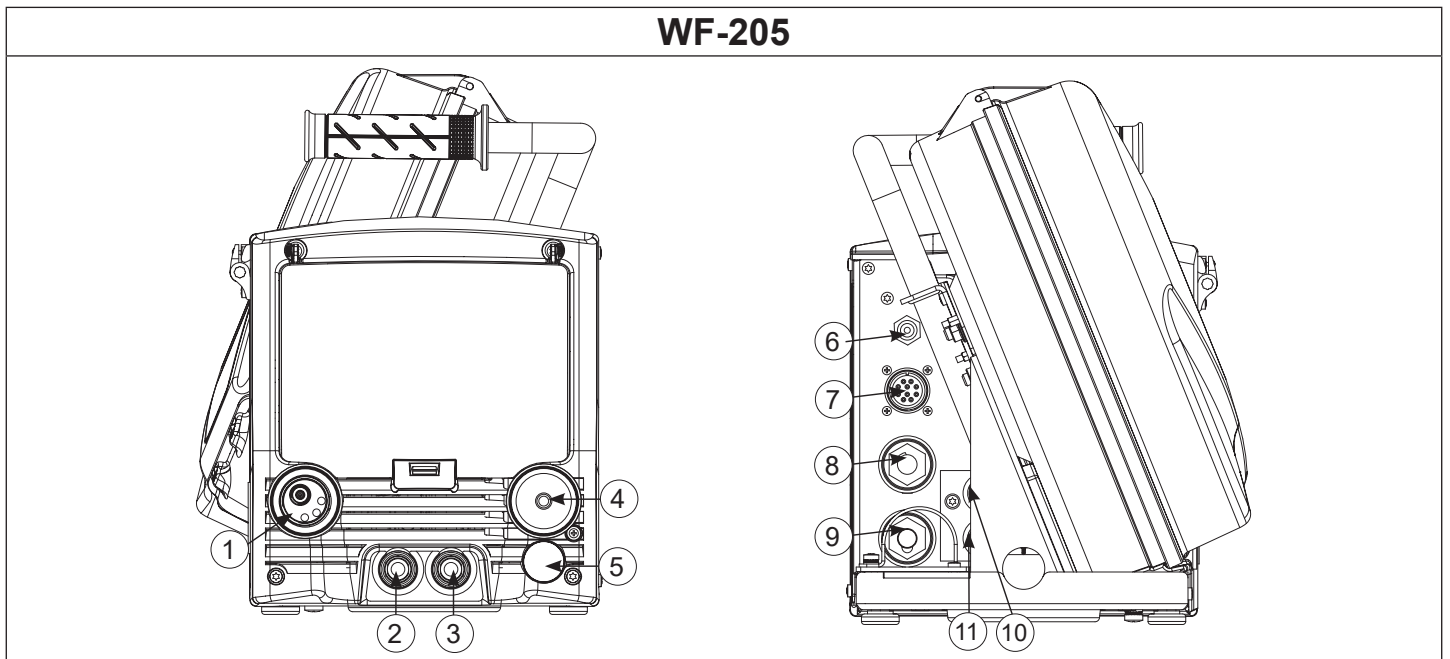
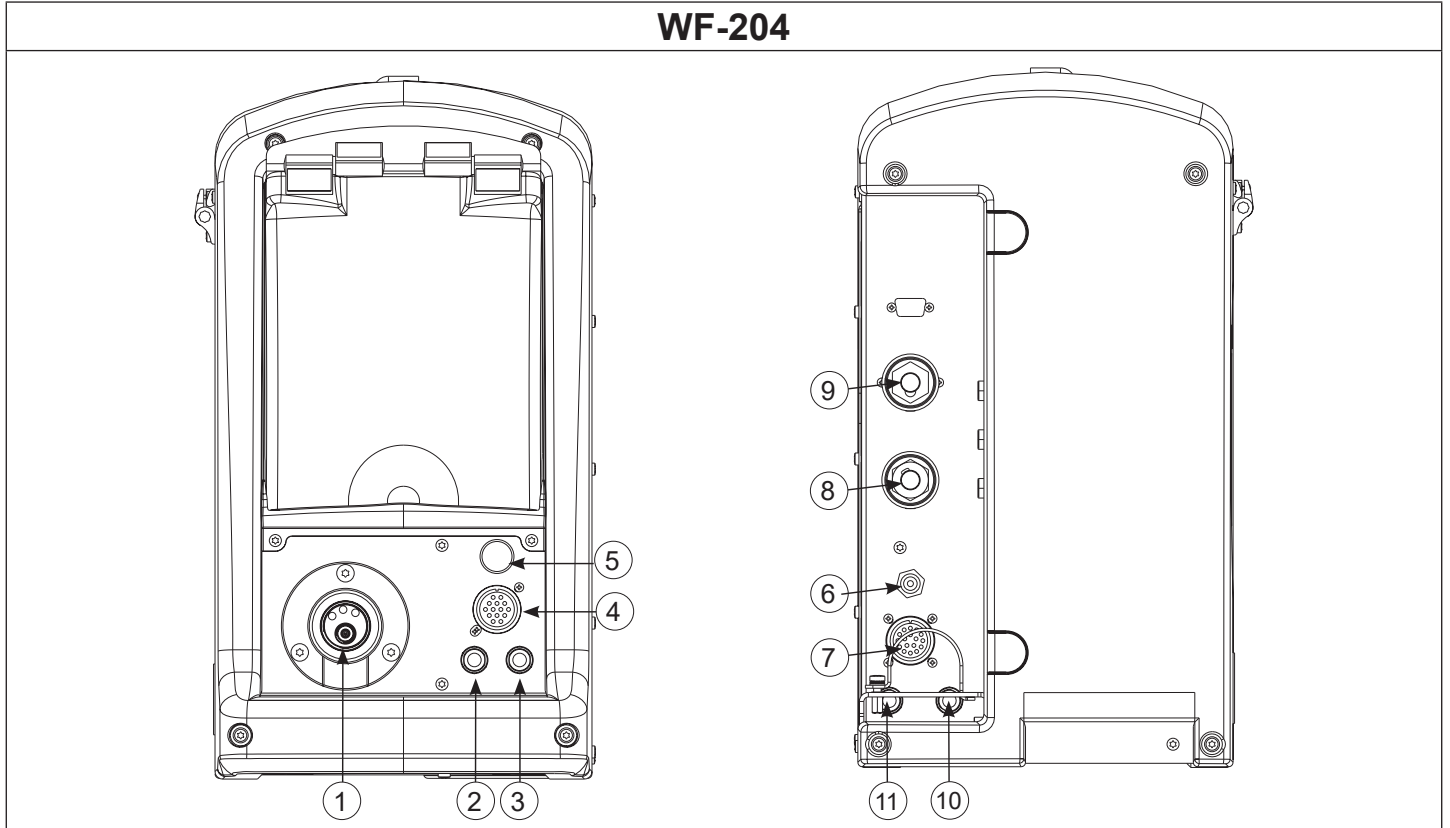

1. Torch socket with EURO connector.
2. Connector for torch coolant return hose (red).
3. Connector for torch coolant delivery hose (blue).
4. Remote control connector.

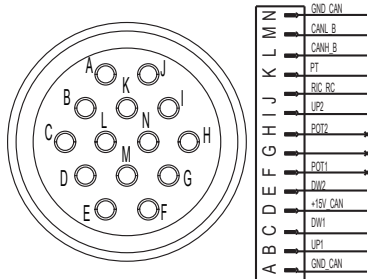

5. Provision for connecting the push pull torch (by purchasing and installing the relevant kit).

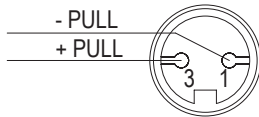

6. Gas rear connector. Provided to connect the gas pipe coming from the cable harness.
7. Cable harness signal connector.

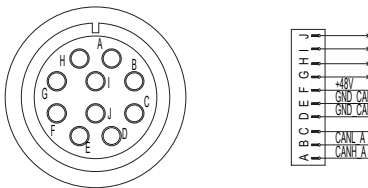

8. Socket provided to connect the power cable coming from the cable harness.
9. MMA socket for welding with coated electrode directly from the wire feeder.
10. Connector to connect the coolant delivery hose from the cooling unit (blue).
11. Connector to connect the coolant return hose from the cooling unit (red).



2.2 MIG/MAG INSTALLATION

 The pictures show the model WF-205 but also apply to model WF-204.



DANGER!
Electric shock hazard!

Read the warnings highlighted by the following symbols in the "General prescriptions for use".





DANGER!
Lifting and positioning

Read the warnings highlighted by the following symbols in the "General prescriptions for use".



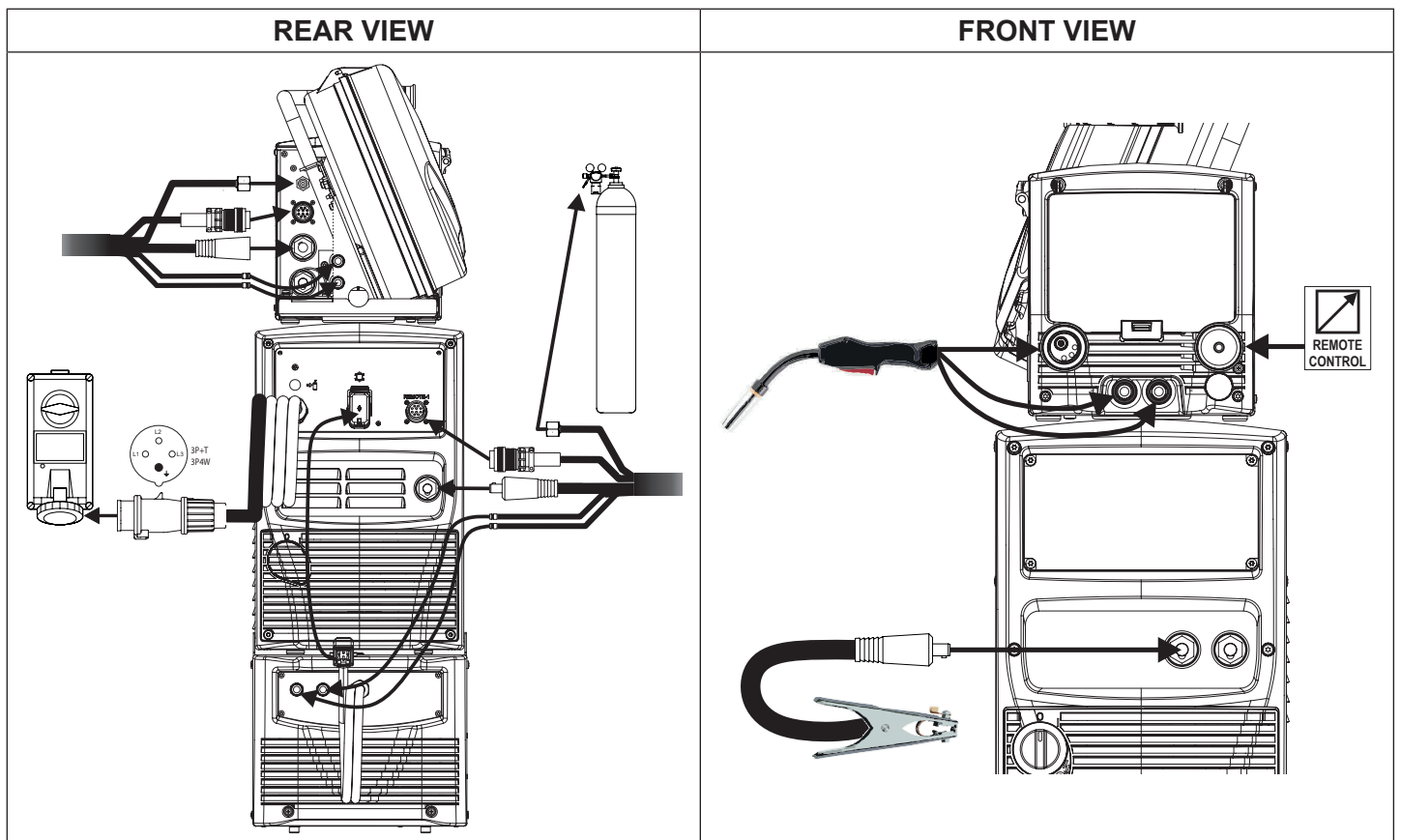

1. Assemble the various units as described in the instruction manual of the power source trolley.
2. Set the welding power source ON/OFF switch to "O" (unit switched off).
3. Connect the power source mains supply cable to the mains socket outlet.
4. Secure the cable harness connectors to the wire feeder.
5. Secure the cable harness connectors to the generator.
6. Connect the power supply cable for the cooling unit to the auxiliary power socket on the power generator.
7. Connect the MIG/MAG torch coolant delivery and return hoses to the coolant fittings located in the wire feeder.
8. Connect the MIG/MAG torch coolant delivery and return hoses of the cable harness to the fittings on the cooling unit and on the wire feeder.
9. Secure the cable harness by fastening the locking device.
10. Connect the earth clamp plug to the power generator earth socket.
11. Connect the earth clamp to the workpiece being processed.
12. Connect the MIG/MAG torch plug to the EURO TORCH welding socket.

2.3 POSITIONING THE SPOOL AND THE WIRE IN THE WIRE FEEDER

The pictures show the model WF-205 but also apply to model WF-204.

WARNING!



Mechanical Hazards

Read the warnings highlighted by the following symbols in the "General prescriptions for use".



<ol style="list-style-type: none"> 1. Fit the spool in the spool holder, ensuring it is located correctly. 2. Secure the spool with the ferrule. 3. Adjust the spool holder braking system by tightening/loosening the screw in such a way that the wire feed force is not excessive and when the spool stops rotating no excess wire is released. 																																																		
<ol style="list-style-type: none"> 4. Check that the feed rolls are suitable for the wire gauge. <ul style="list-style-type: none"> ○ The diameter of the roll groove must be compatible with the diameter of the welding wire. ○ The roll must be of suitable shape in relation to the composition of the wire material. 5. Feed the wire between the wire feeder rolls and insert it into the MIG/MAG TORCH connector plug. 6. Make sure the wire is located correctly in the roll grooves. 	<table border="1" style="margin-top: 10px; font-size: 8px;"> <thead> <tr> <th>Ø mm</th> <th>U</th> <th>V</th> <th>VK</th> </tr> </thead> <tbody> <tr> <td>0,6-0,8</td> <td></td> <td>002.0000.0140</td> <td></td> </tr> <tr> <td>0,8-1,0</td> <td>002.0000.0144</td> <td>002.0000.0141</td> <td></td> </tr> <tr> <td>1,0-1,2</td> <td>002.0000.0145</td> <td>002.0000.0142</td> <td>002.0000.0143</td> </tr> <tr> <td>1,2-1,6</td> <td>002.0000.0146</td> <td>002.0000.0143</td> <td>002.0000.0150</td> </tr> <tr> <td>1,6-2,0</td> <td>002.0000.0147</td> <td></td> <td></td> </tr> <tr> <td>2,4-3,2</td> <td>002.0000.0148</td> <td></td> <td>002.0000.0151</td> </tr> </tbody> </table> <table border="1" style="margin-top: 10px; font-size: 8px;"> <thead> <tr> <th>Ø mm</th> <th>U</th> <th>VK</th> </tr> </thead> <tbody> <tr> <td>1,0-1,2</td> <td>002.0000.0145</td> <td>002.0000.0149</td> </tr> <tr> <td>1,2-1,6</td> <td>002.0000.0146</td> <td>002.0000.0150</td> </tr> <tr> <td>2,4-3,2</td> <td></td> <td>002.0000.0151</td> </tr> </tbody> </table> <table border="1" style="margin-top: 10px; font-size: 8px;"> <thead> <tr> <th>Ø mm</th> <th>U</th> <th>U TEFLON</th> </tr> </thead> <tbody> <tr> <td>1,0-1,2</td> <td>002.0000.0163</td> <td>002.0000.0171</td> </tr> <tr> <td>1,2-1,6</td> <td>002.0000.0169</td> <td>002.0000.0172</td> </tr> </tbody> </table> <p style="font-size: 8px; margin-top: 5px;">U= (Al) V= (Fe/SS) VK= (Cu)</p>	Ø mm	U	V	VK	0,6-0,8		002.0000.0140		0,8-1,0	002.0000.0144	002.0000.0141		1,0-1,2	002.0000.0145	002.0000.0142	002.0000.0143	1,2-1,6	002.0000.0146	002.0000.0143	002.0000.0150	1,6-2,0	002.0000.0147			2,4-3,2	002.0000.0148		002.0000.0151	Ø mm	U	VK	1,0-1,2	002.0000.0145	002.0000.0149	1,2-1,6	002.0000.0146	002.0000.0150	2,4-3,2		002.0000.0151	Ø mm	U	U TEFLON	1,0-1,2	002.0000.0163	002.0000.0171	1,2-1,6	002.0000.0169	002.0000.0172
Ø mm	U	V	VK																																															
0,6-0,8		002.0000.0140																																																
0,8-1,0	002.0000.0144	002.0000.0141																																																
1,0-1,2	002.0000.0145	002.0000.0142	002.0000.0143																																															
1,2-1,6	002.0000.0146	002.0000.0143	002.0000.0150																																															
1,6-2,0	002.0000.0147																																																	
2,4-3,2	002.0000.0148		002.0000.0151																																															
Ø mm	U	VK																																																
1,0-1,2	002.0000.0145	002.0000.0149																																																
1,2-1,6	002.0000.0146	002.0000.0150																																																
2,4-3,2		002.0000.0151																																																
Ø mm	U	U TEFLON																																																
1,0-1,2	002.0000.0163	002.0000.0171																																																
1,2-1,6	002.0000.0169	002.0000.0172																																																
<ol style="list-style-type: none"> 7. Adjust the pressure system so that the arms press the wire with a force that does not deform it while also ensuring constant feed rate without slipping. 	<table border="1" style="margin-right: 10px; font-size: 8px;"> <tbody> <tr> <td>mild steel</td> <td>2,5</td> </tr> <tr> <td>stainless steel</td> <td>3,5</td> </tr> <tr> <td>brazing</td> <td></td> </tr> <tr> <td>aluminium</td> <td>1-2</td> </tr> <tr> <td>flux-cored</td> <td>2-3</td> </tr> </tbody> </table>	mild steel	2,5	stainless steel	3,5	brazing		aluminium	1-2	flux-cored	2-3																																							
mild steel	2,5																																																	
stainless steel	3,5																																																	
brazing																																																		
aluminium	1-2																																																	
flux-cored	2-3																																																	
<ol style="list-style-type: none"> 8. Press the key to feed the wire until it protrudes from the torch tip. 																																																		

The wire feed can also be activated by the torch trigger in this manner:

- press the key  and the torch trigger at the same time,
- release the key  but keep the torch trigger pressed. The wire will continue to be fed;
- release the torch trigger to stop wire feeding.

2.4 PREPARING FOR MMA WELDING

1. Set the welding power source ON/OFF switch to “O” (unit switched off).
2. Plug the power cable plug into a mains socket outlet.
3. Choose the electrode based on the type of material and thickness of the workpiece to be welded.
4. Insert the electrode in the electrode holder.
5. Connect the electrode holder cable to the welding socket based on the polarity requested by the type of electrode used.
6. Connect the plug of the ground clamp to the welding socket on the basis of the polarity required.
7. Connect the earth clamp to the workpiece being processed.



DANGER!

Electric shock hazard!

Read the warnings highlighted by the following symbols in the “General prescriptions for use”.



8. Set the welding power source ON/OFF switch to “I” (unit switched on).

9. Select the following welding mode on the user interface: MMA

10. Set the required welding parameter values on the user interface.

When the remote controller [RC] is connected and the relative locking screw is tightened, welding current can be adjusted using the remote controller.

The system is ready to start welding.

REAR VIEW

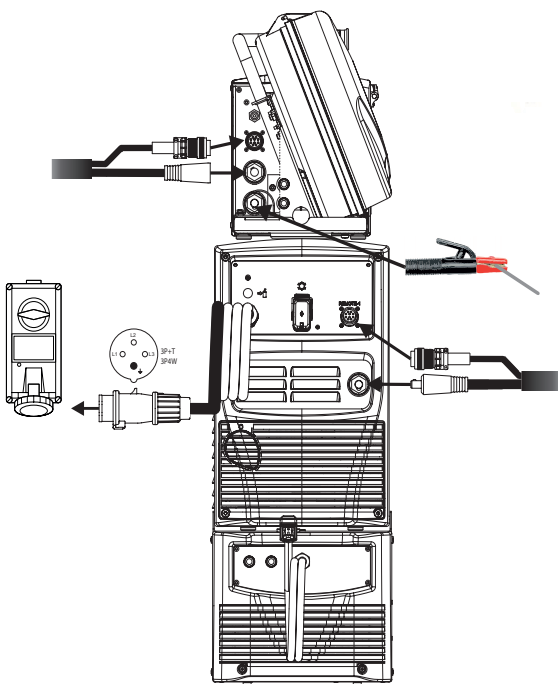

FRONT VIEW
(polarity to basic electrode)

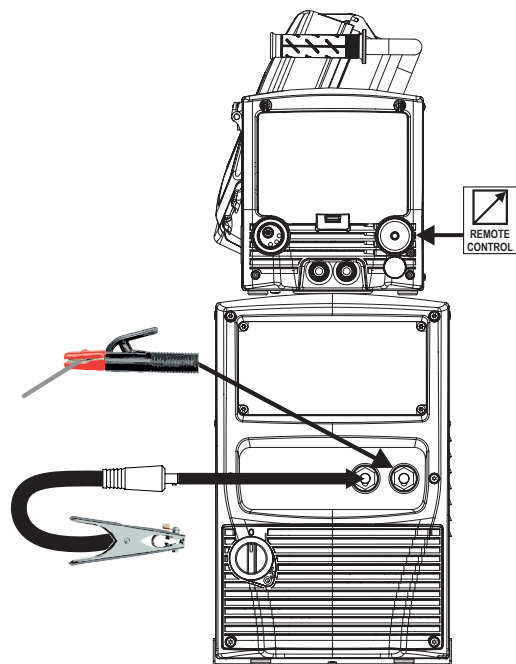

2.5 PREPARING FOR TIG WELDING

NOTE: Refer to the cooling unit instruction manual for the cooling unit to power source assembly procedure.

1. Set the welding power source ON/OFF switch to "O" (unit switched off).
2. Plug the power cable plug into a mains socket outlet.
3. Connect the gas hose from the welding gas cylinder to the rear gas connection.
4. Open the cylinder gas valve.
5. Choose the electrode based on the type of material and thickness of the workpiece to be welded.
6. Insert the electrode in the TIG torch.
7. Connect the torch plug to the welding socket on the basis of the polarity required by the type of electrode in question.
8. Connect the plug of the ground clamp to the welding socket on the basis of the polarity required.
9. Connect the earth clamp to the workpiece being processed.
10. Set the welding power source ON/OFF switch to "I" (unit switched on).
11. Select the following welding mode on the user interface: DC TIG
12. Press the torch trigger with the torch well clear of any metal parts. This serves to open the gas solenoid valve without striking the welding arc.
13. Use the flow control valve to adjust the flow of gas as required while the gas is flowing out.
14. Set the required welding parameter values on the user interface.

When the remote control pedal is connected and the relative locking screw is tightened the welding current will vary in relation to the pressure exerted on the pedal.

The system is ready to start welding.

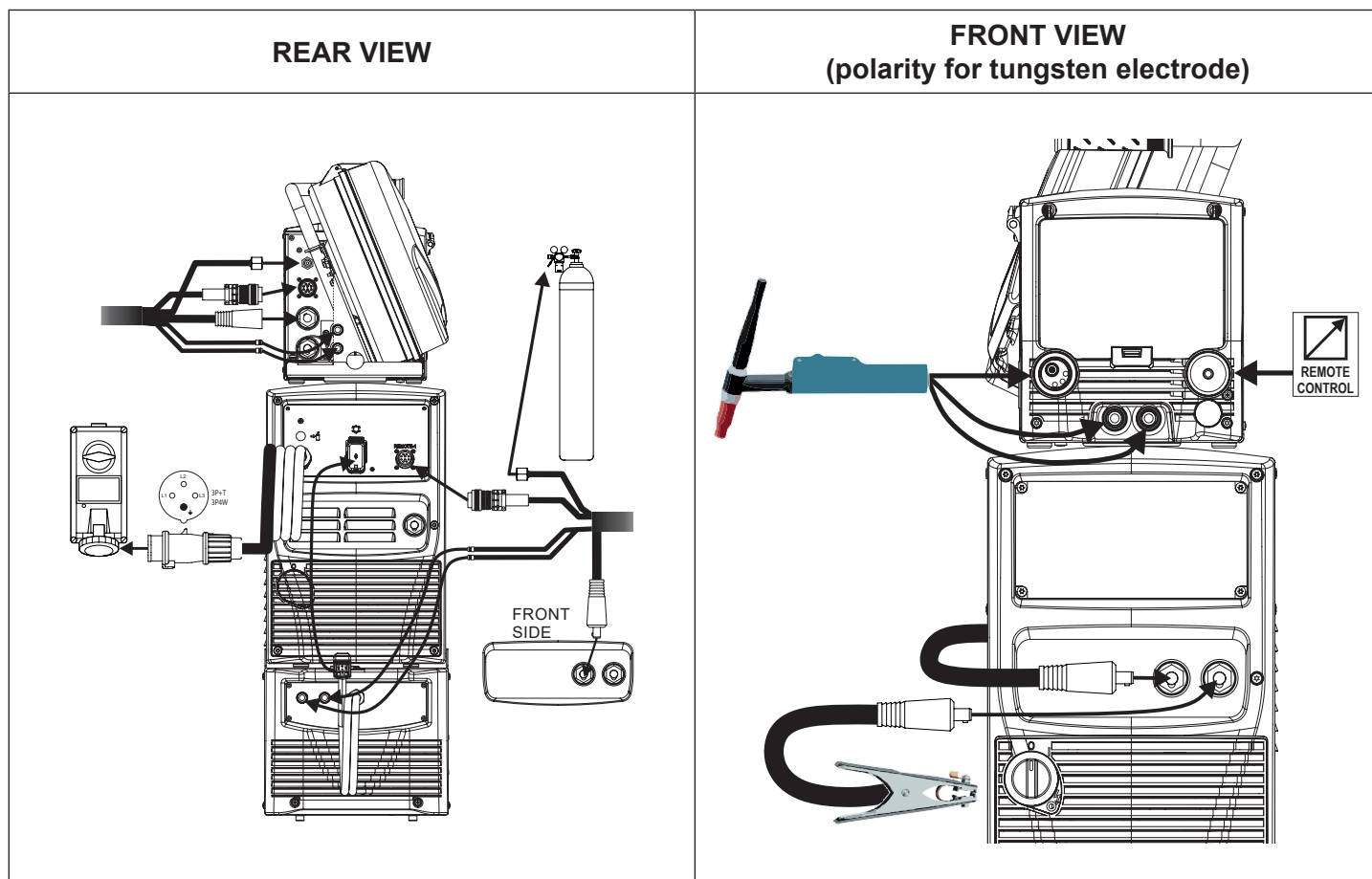

3 USER INTERFACE

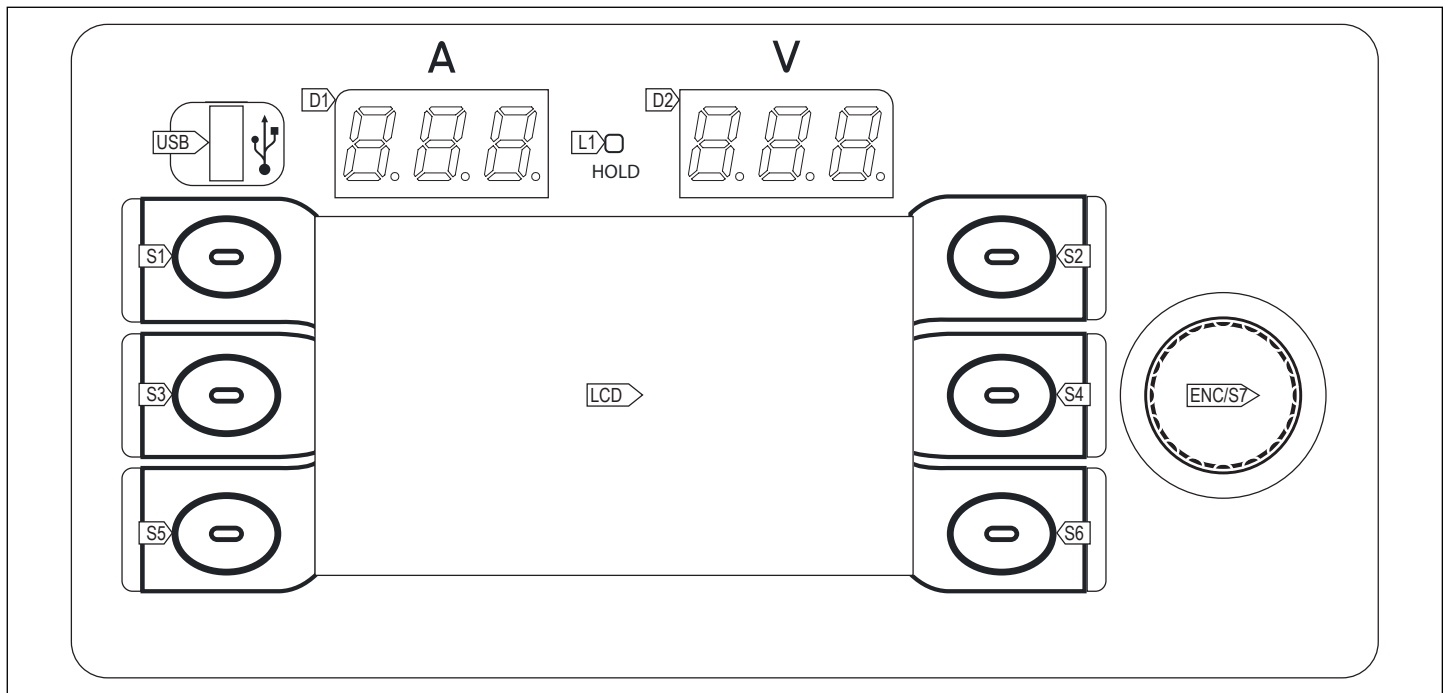







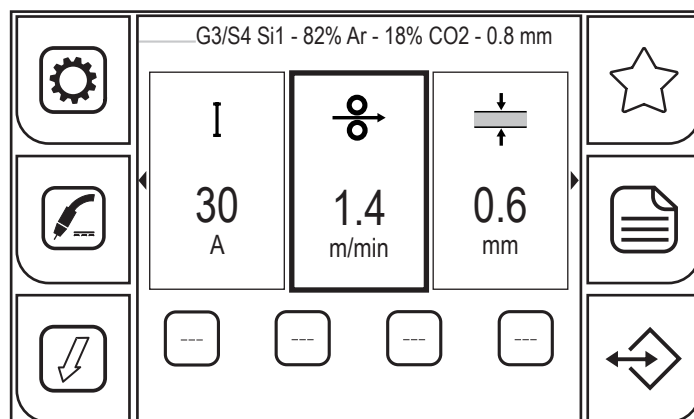

CODE	SYMBOL	DESCRIPTION
L1		When the indicator light goes on, it shows the last voltage and current value measured during the welding operation on displays D1 and D2. The LED is switched off when a new welding procedure is started, or when any of the welding settings is changed.
D1		During the welding operation: The display shows the effective amperes used when welding. With HOLD led on: The display shows the last measured current value..
D2		During the welding operation: The display shows the effective voltage used when welding. With HOLD led on: The display shows the last measured voltage value.
LCD		The display shows the menus available to set up the welder and its functions. During the welding operation: The display shows the welding parameters set.
S1, S2, S3, S4, S5, S6		Multi-function keys: these keys are associated with specific functions, which vary according to the currently viewed menu screens and to the currently used settings. The function assigned to each key is shown by the icon that appears next to it.
ENC/S7		ENCODER WITH BUILT-IN KEY In the menu screens: By using the encoder, the parameters/settings list can be scrolled. By pressing the encoder (ENCODER KEY) the highlighted settings can be selected. During the welding operation: the encoder changes the value of the active parameter.
USB		Porta per connettere una chiavetta USB per l'esportazione/importazione dei JOB. Tramite la porta USB è possibile aggiornare il firmware di sistema dell'impianto

The touchscreen panel allows the user to set up the functions through the mechanical keys or by touching the icons displayed on the screen.

3.1 MAIN SCREEN



KEYS WITH SYMBOLS

	<p>- (MIG/MAG): The (PROGRAM) key allows the user to access a sequence of screens to be used to program the parameters required to specify a welding curve.</p> <p>- (MMA): Press the (PROGRAM) key to select the type (material) of electrode.</p>
	<p>The (FAVORITE) key allows the user to access the SHORTCUT menu, which allows the  (SHORTCUT) keys to be associated to a specific function selected from the available functions.</p>
	<p>Press the (PROCESS) key to select the welding process. The following processes can be selected: PULSED MIG/MAG, MIG/MAG SHORT/SPRAY, MMA, ARC AIR, TIG LIFT.</p> <p>In MIG/MAG mode the user can select through a sequence of screens the welding processes compatible with the material, wire diameter and gas values which have been previously set through the program key.</p>
	<p>The (PARAMETERS MENU) allows the user to access the menu used to set up the main welding features. This menu also contains special functions, such as the welding circuit calibration and the system menu. It also contains special functions, such as: the welding circuit calibration, the system menu, import/export.</p>
	<p>The (MODE) key allows the user to access the menu used to select the torch trigger mode.</p>
	<p>The (JOB) key allows the JOB management menu to be accessed.</p>
	<p>The (SHORTCUT) key allows the associated function to be directly accessed. By pressing this key, the function is enabled (yellow background); by pressing it again, the function is disabled. This key only works with the touch screen.</p> <p>Keep the  (SHORTCUT) key pressed for 3 seconds to access the functions screen.</p>

3.2 SETTING UP THE WELDING PARAMETERS

This area of the screen displays the welding parameters that can be directly set from the main screen.

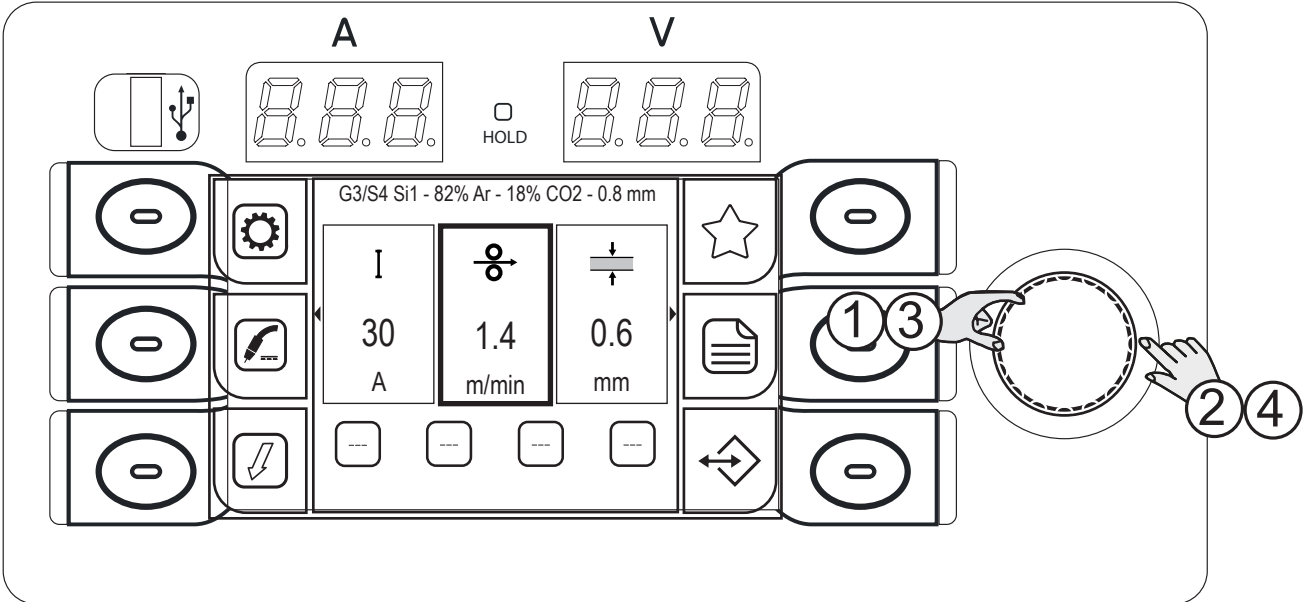

1. Turn the encoder to select the parameter to be changed; the selection made is highlighted by the thicker edge around the box.
2. Press the (ENCODER) key; the background of the box will change colour.
3. Turn the encoder to set the desired value.
4. Press the (ENCODER) key again to return to the parameter selection mode.

The following parameters can be set:

U
20.0
V

(MIG/MAG)
Welding voltage
Sets the welding voltage.

I
140
A

(MIG/MAG, MMA, ARC AIR, TIG LIFT)
Welding current
Sets the welding current.

⊘
10.4
m/min

(MIG/MAG)
Wire speed
Sets the wire speed for welding.

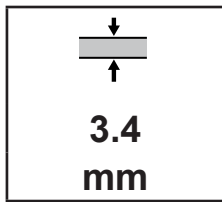

(MIG/MAG)
Material thickness
Sets the thickness of the material to be welded.

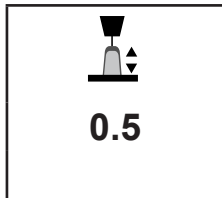

(MIG/MAG)
Arc length correction
Sets up the welding arc length correction in relation to the preset value from the synergic curve.



(MIG/MAG)
Inductance (in the short-spray process)
Changes the energy when a short circuit occurs.

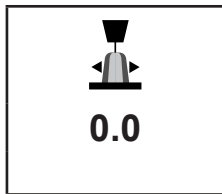

(MIG/MAG)
Dynamic (in the pulsed process)
Corrects the energy of the pulsed arc pulses.

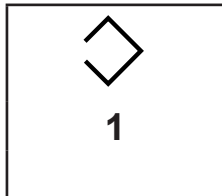

(MIG/MAG, MMA, ARC AIR, TIG LIFT)
Selected JOB
Displays the currently loaded JOB.
The icon is displayed only if a JOB is loaded.

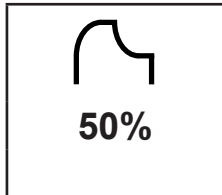

(MMA)
Hot-start
Set the HOT-START peak current value to allow the electrode welding to be easily triggered.

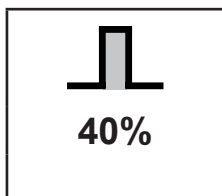

(MMA)
Arc-Force
Set the ARC-FORCE peak current value to allow the electrode to slide during the welding process and to prevent electrode sticking.

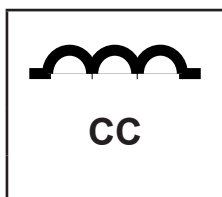

(MMA)
Dynamic (in the electrode welding process)
Changes the short-circuit energy when the drop is detached

VIEWING ADDITIONAL INFORMATION

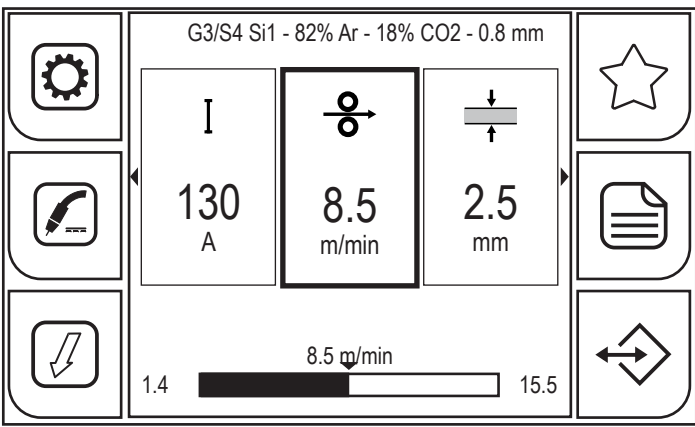
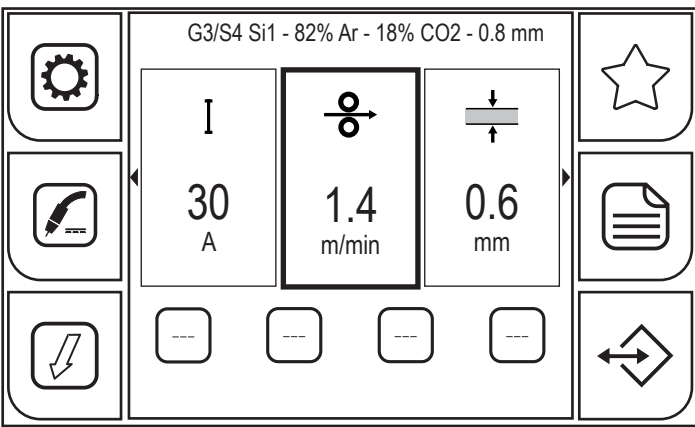
	
<p>During a parameter setting operation The bar displays the minimum value, the currently set value and the selected parameter maximum value.</p>	<p>Outside a parameter setting operation The active welding settings are displayed (filler wire material, gas, thickness of the material to be welded, b-level activation, double pulse mode activation, loaded JOB).</p>

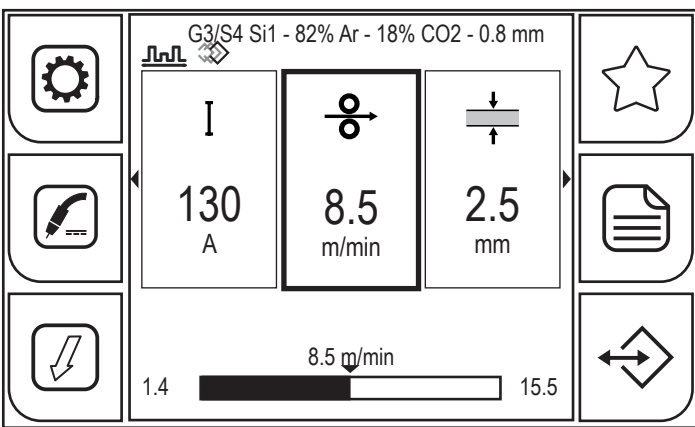

<p>After activating a function Below the active synergic curve wording, the icons of the active functions will appear.</p>

4 PRELIMINARY SETTINGS

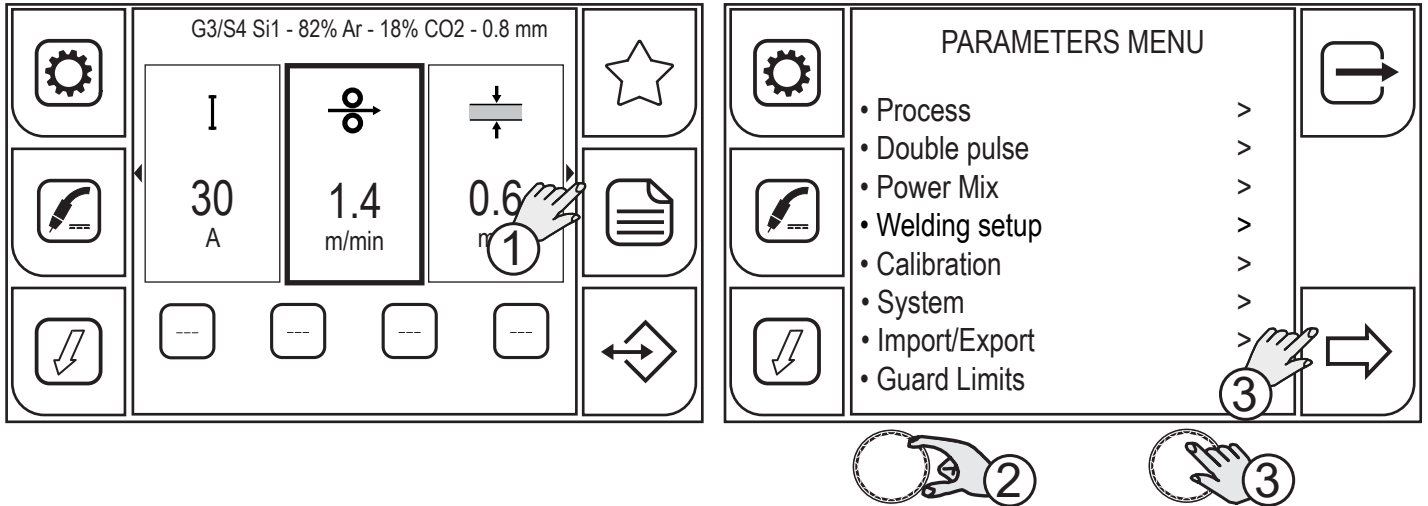
4.1 SETTING THE LANGUAGE

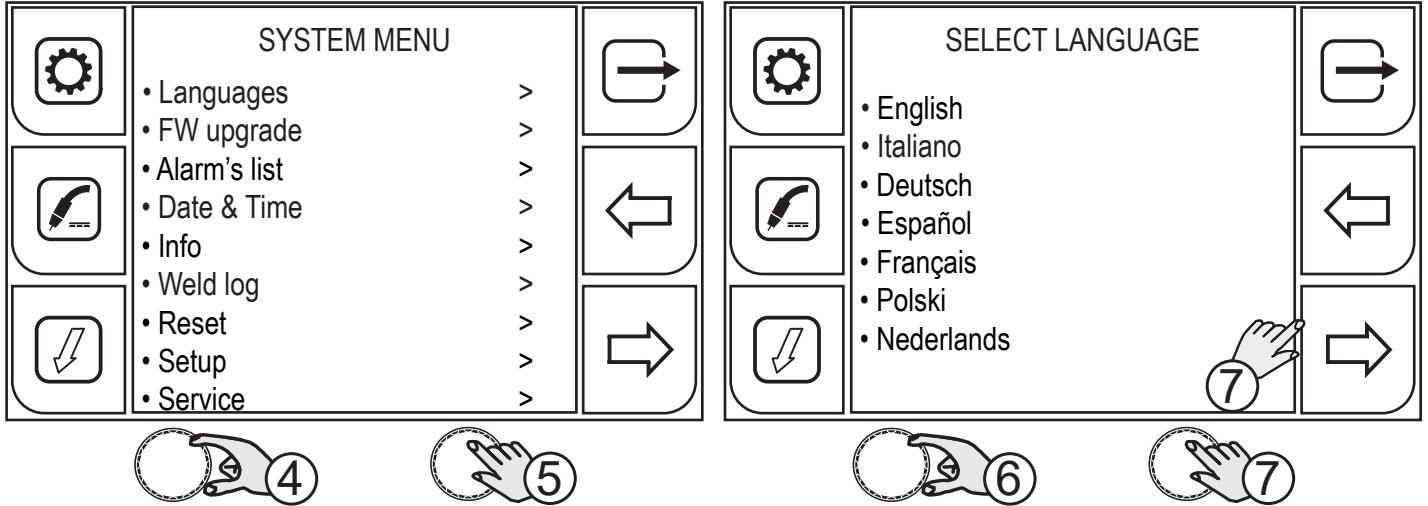

1. Press the (MENU) key.
2. Turn the encoder to select the desired setting. Select the following path: System>
3. Press the (ENCODER) key or the (NEXT) key to confirm.



4. Turn the encoder to select the desired setting. Select the following path: Languages>
5. Press the (ENCODER) key or the (NEXT) key to confirm.
6. Turn the encoder to select the desired language.
 - (English, Italiano, Deutsch, Espanol, Francais, Polski, Nederlands, Romana)
7. Press the (ENCODER) key or the (NEXT) key to confirm.

Press the key to exit the screen.

4.2 FIRMWARE UPGRADE

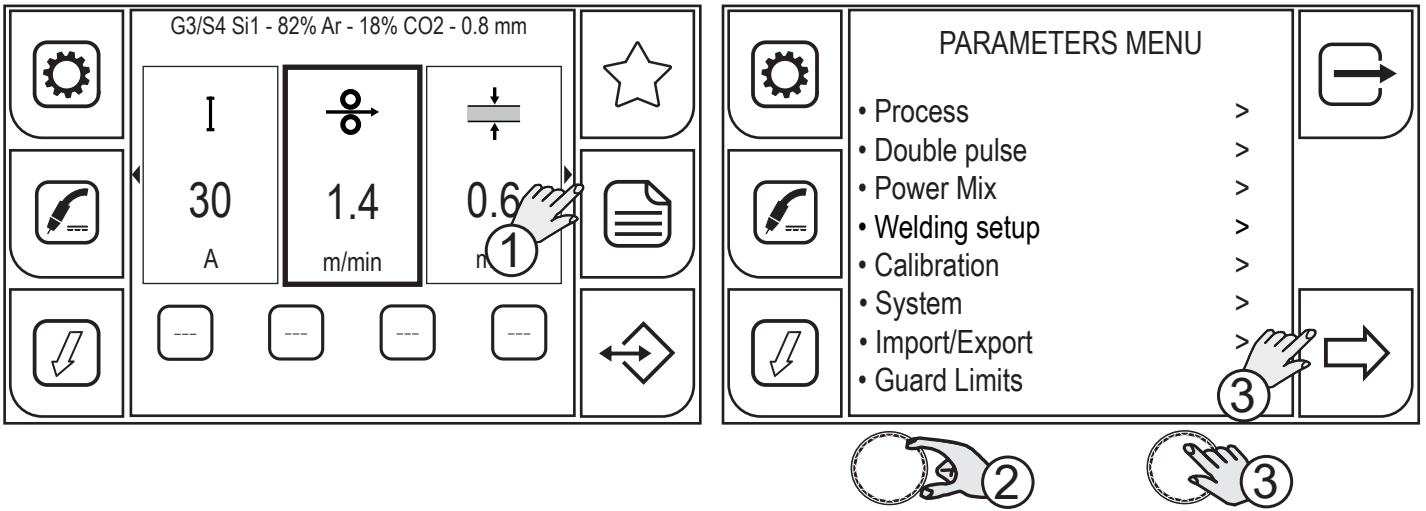

1. Press the (MENU) key.
2. Turn the encoder to select the desired setting. Select the following path: System>
3. Press the (ENCODER) key or the (NEXT) key to confirm.

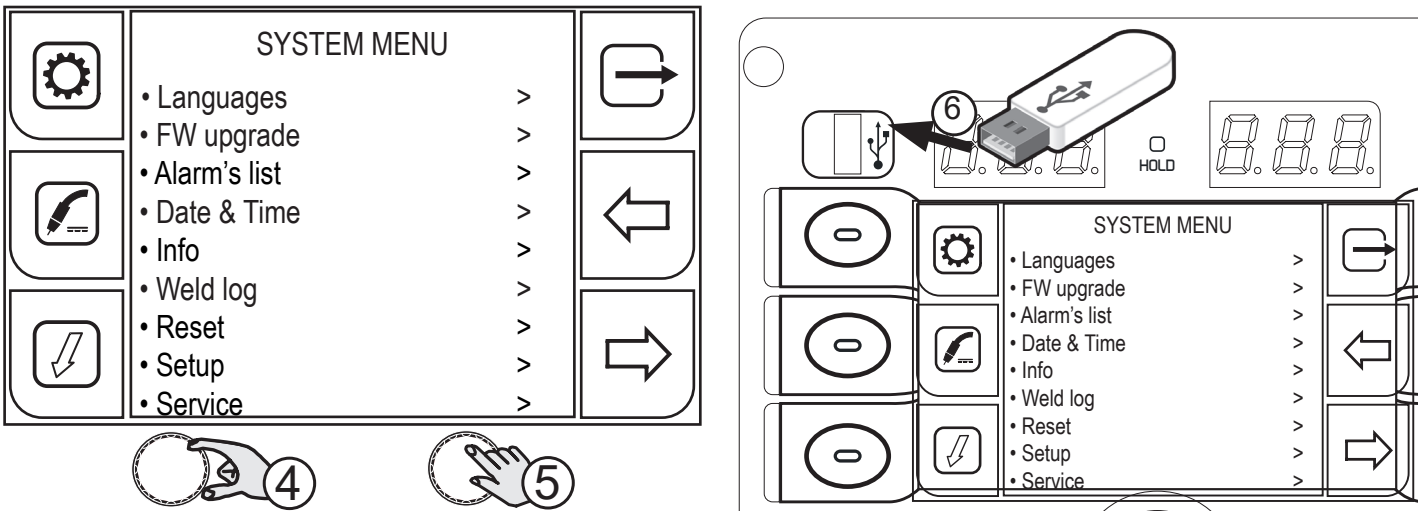

4. Turn the encoder to select the desired setting. Select the following path: FW upgrade>
5. Press the (ENCODER) key or the (NEXT) key to confirm.
6. Insert the USB pen drive loaded with the firmware in the relevant port.

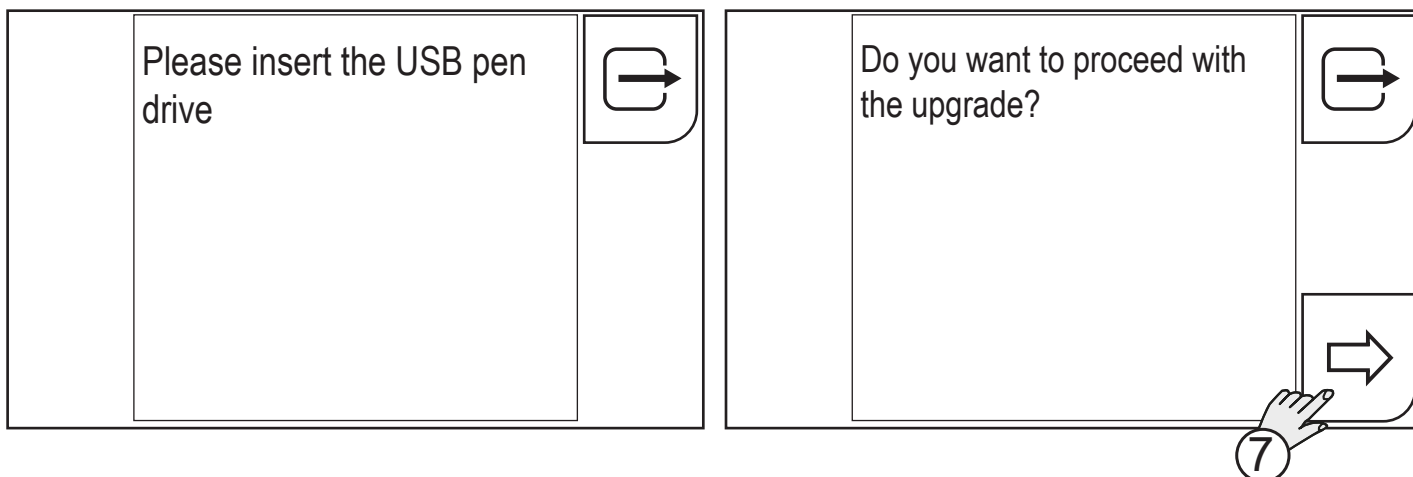

7. Press the (YES) key

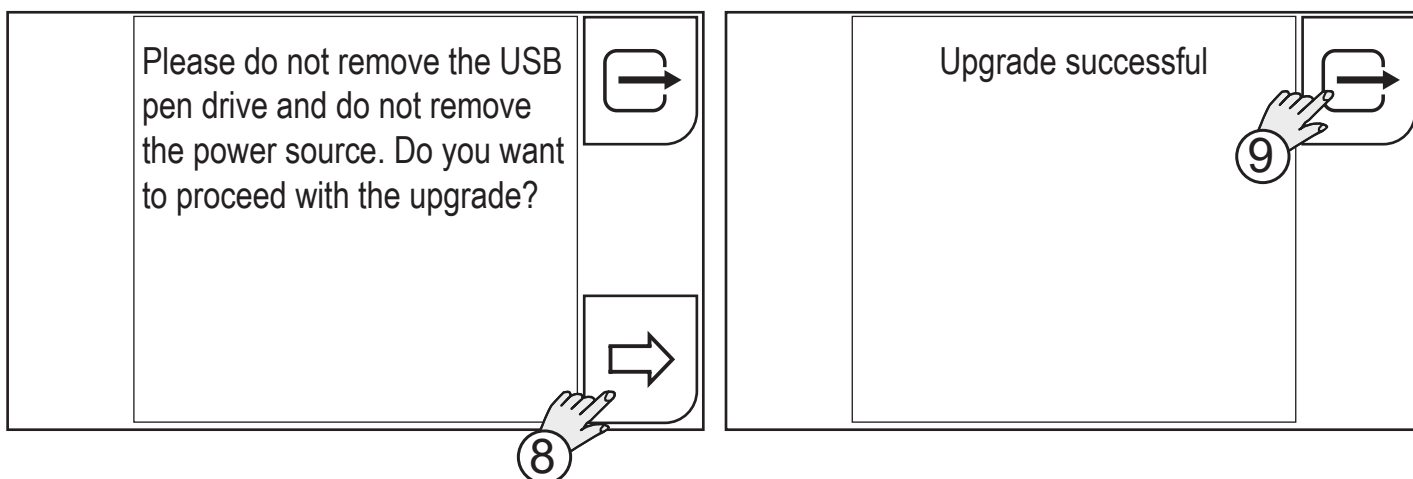

8. Press the (OK) key

Press the  (EXIT) key to go back to the home page.
Wait for the upgrading procedure to be completed.

9. Press the (OK) key

Any problems encountered during the upgrade will be shown on the display.

WARNING	MEANING
Release file not found	File not found in the USB pen drive.
No USB/SD card found	USB pen drive not recognised (missing or incorrectly inserted). <ul style="list-style-type: none"> - Make sure that the USB pen drive has been inserted correctly. - Use a different USB pen drive.
Could not decrypt release file	Corrupted file or edited file name (<u>never rename the upgrade file supplied</u>).
Could not inflate release file	Corrupted file or edited file name (<u>never rename the upgrade file supplied</u>).
Update directory and/or script not found	Corrupted file or edited file name (<u>never rename the upgrade file supplied</u>).
Update procedure failed	Contact our technical service.
Upgrade package is not for this board	The file loaded on the USB pen drive is not compatible with the electronic board.
Could not find readme file in upgrade package	Contact our technical service.
Installed version and upgrade package version do not match	The installed software cannot be downgraded.
Could not upgrade generator	Contact our technical service.
Could not upgrade wf	Contact our technical service.
Could not upgrade boost	Contact our technical service.

4.3 SETTING THE DATE AND TIME

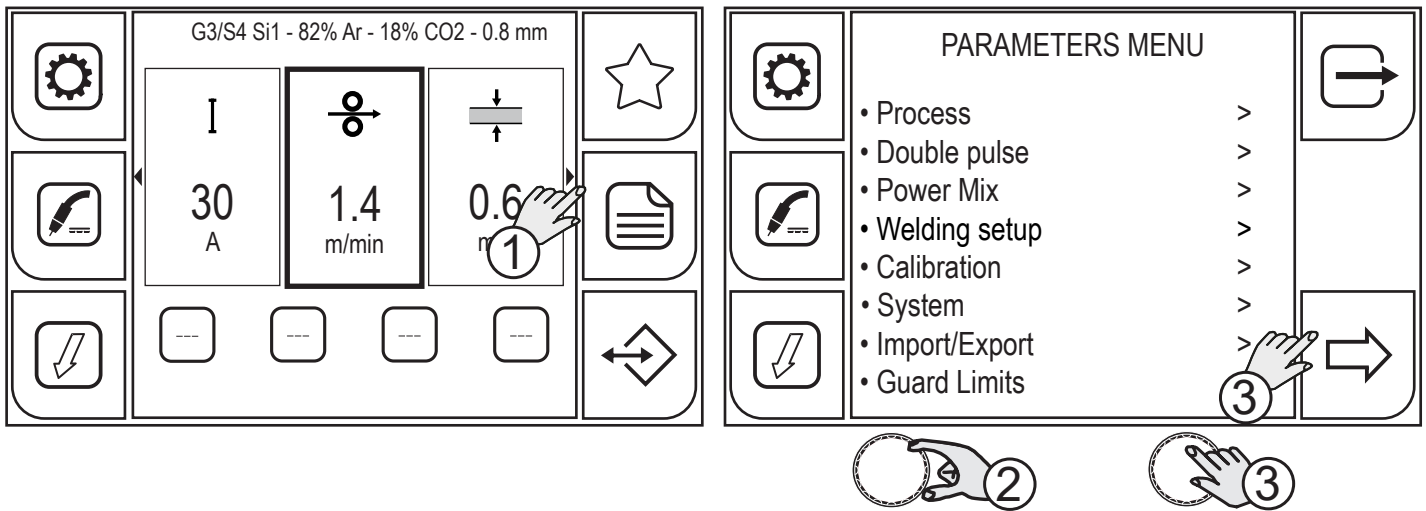

1. Press the (MENU) key.
2. Turn the encoder to select the desired setting. Select the following path: System>
3. Press the (ENCODER) key or the (NEXT) key to confirm.

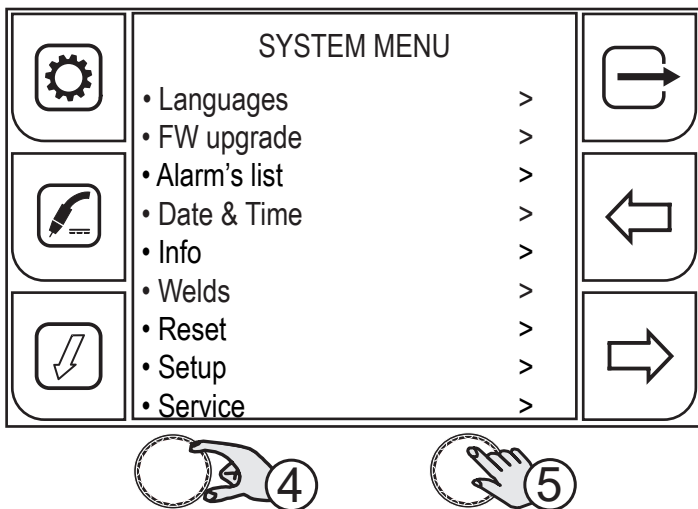

4. Turn the encoder to select the desired setting. Select the following path: Date & Time>
5. Press the (ENCODER) key or the (NEXT) key to confirm.

ENGLISH

4.3.1 SETTING THE TIME ZONE

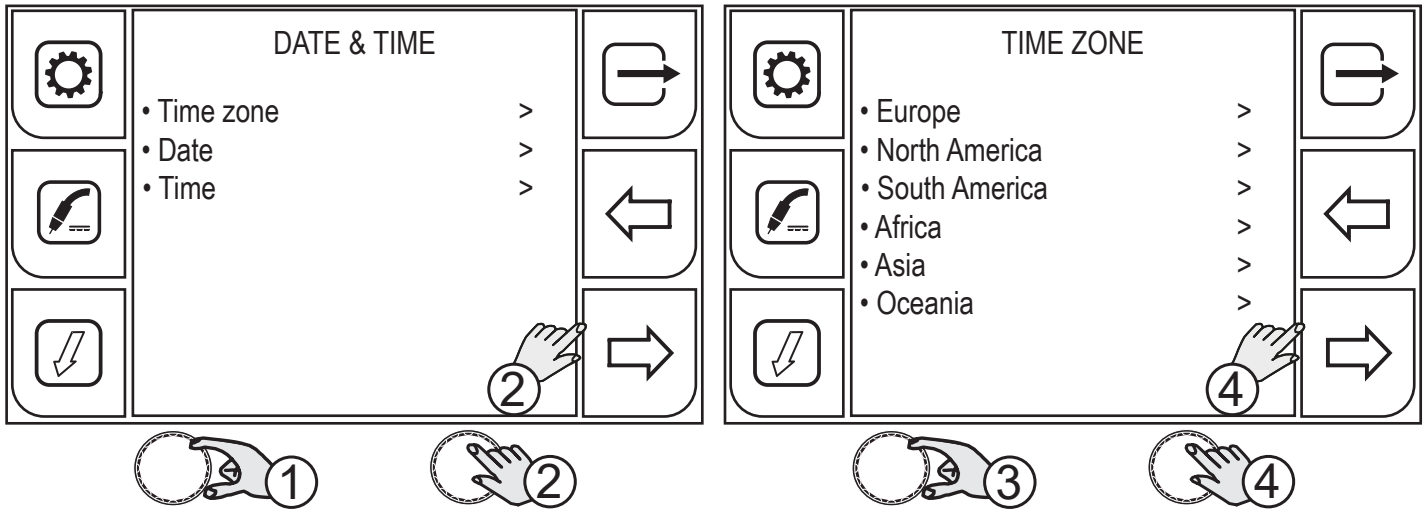

1. Turn the encoder to select the desired setting. Select the following path: Time zone>
2. Press the (ENCODER) key or the (NEXT) key to confirm.
3. Turn the encoder to select the desired time zone.
4. Press the (ENCODER) key or the (NEXT) key to confirm.

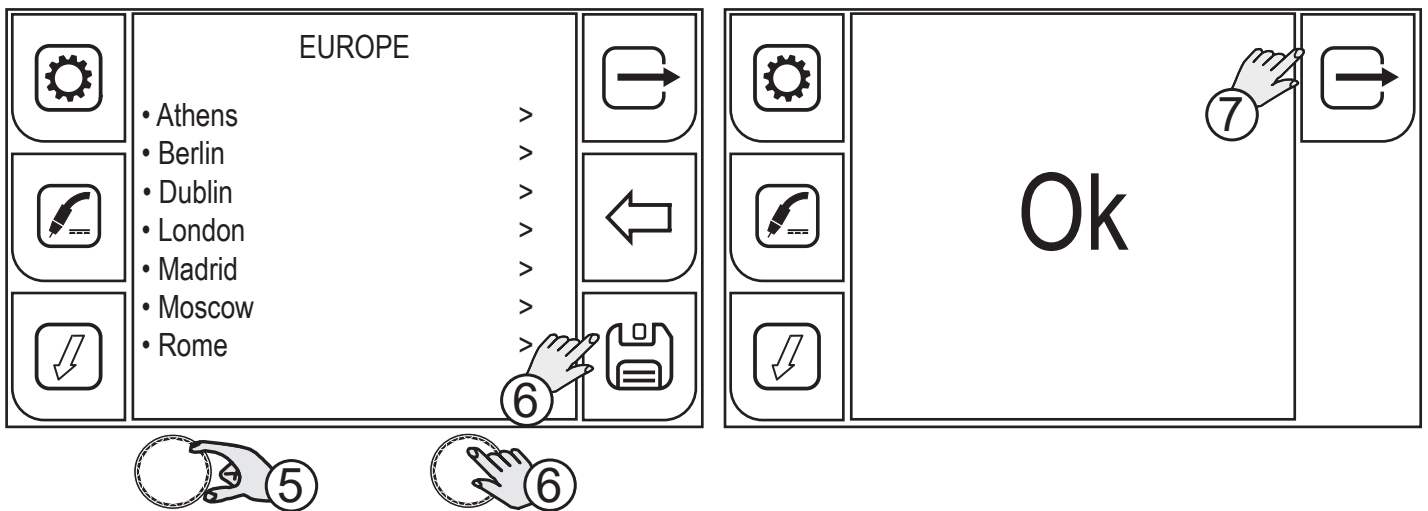

5. Turn the encoder to select the desired city.
6. Press the (ENCODER) key or the (NEXT) key to confirm.
7. Press the (OK) key to confirm your selection.

To exit the screen, press the  key.

4.3.2 SETTING THE DATE

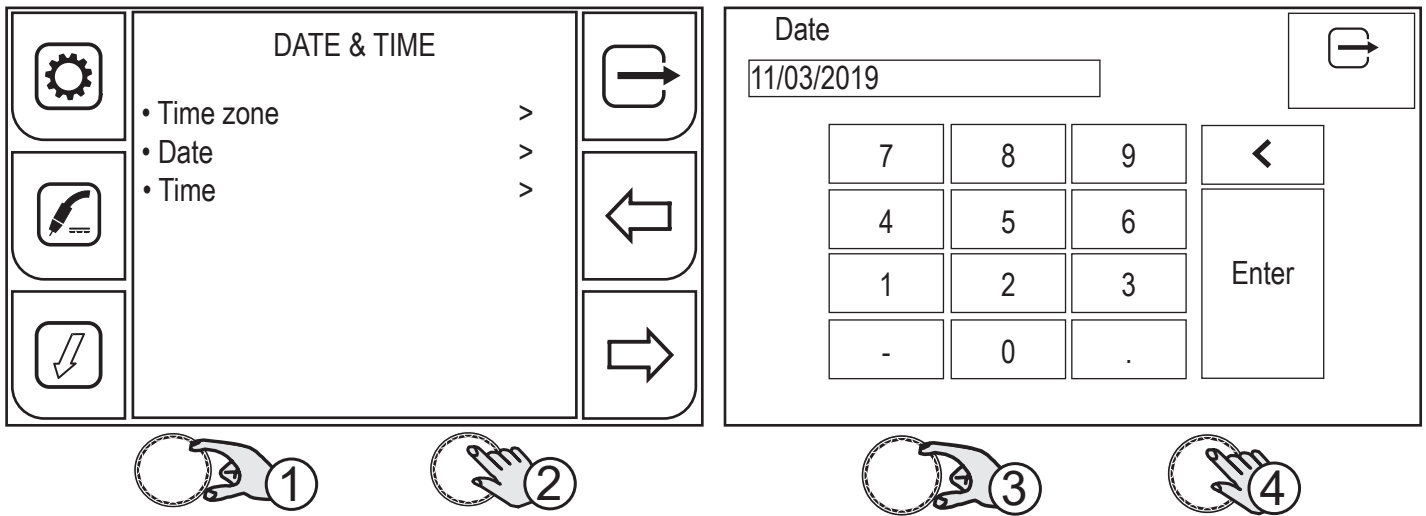

1. Turn the encoder to select the desired setting. Select the following path: Date>
2. Press the (ENCODER) key or the (NEXT) key to confirm.

 The touchscreen panel allows the user to set up the functions through the mechanical keys or the icons appearing on the screen.

3. Turn the encoder to select the number on the keyboard.
4. Press the key (ENCODER) to confirm your selection.

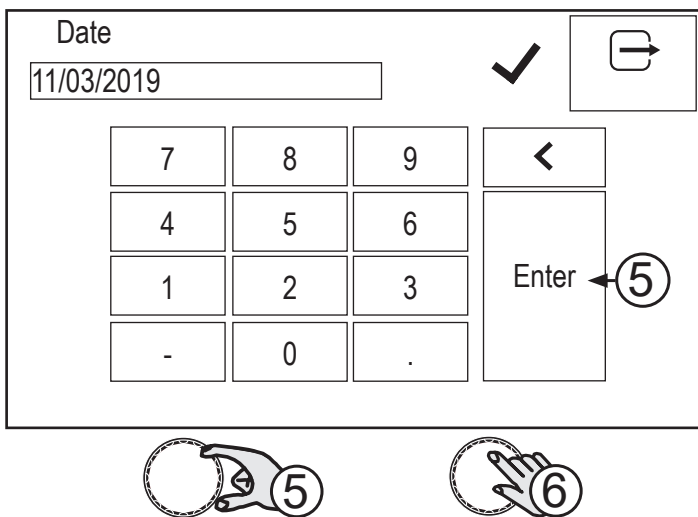

5. Turn the encoder to select the (ENTER) symbol on the keyboard.
6. Press the (ENCODER) key to confirm your selection. A green tick will appear to indicate that the operation has been confirmed.

To exit the screen, press the  key.

4.3.3 SETTING THE TIME

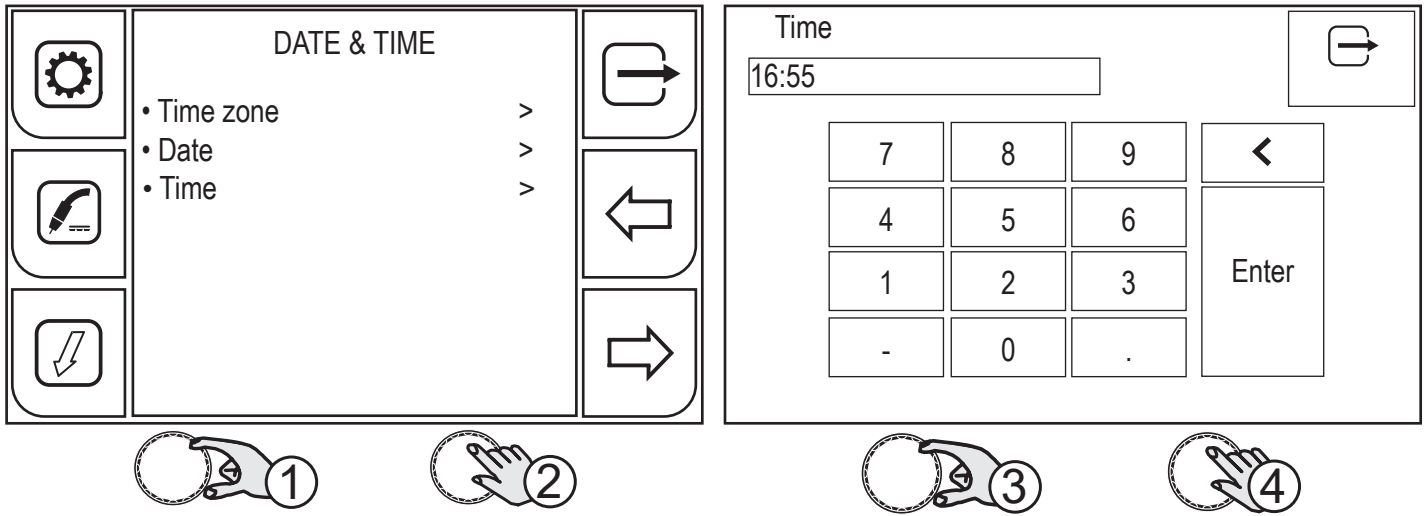

1. Turn the encoder to select the desired setting. Select the following path: Time>
2. Press the (ENCODER) key or the (NEXT) key to confirm.

 The touchscreen panel allows the user to set up the functions through the mechanical keys or the icons appearing on the screen.

3. Turn the encoder to select the number on the keyboard.
4. Press the (ENCODER) key to confirm your selection.

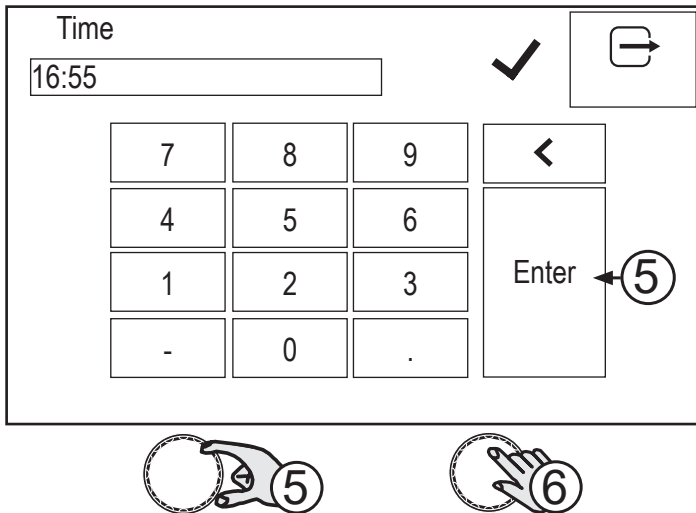

5. Turn the encoder to select the (ENTER) symbol on the keyboard.
6. Press the (ENCODER) key to confirm your selection. A green tick will appear to indicate that the operation has been confirmed.

To exit the screen, press the  key.

4.4 SETTING UP THE WELDER

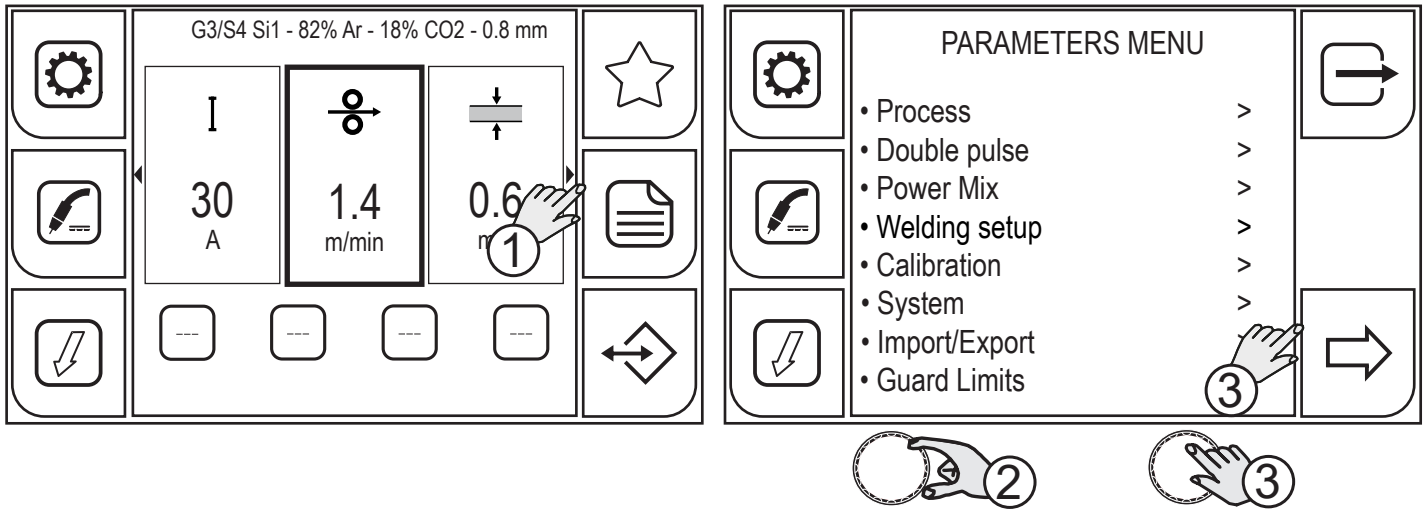

1. Press the (MENU) key.
2. Turn the encoder to select the desired setting. Select the following path: System>
3. Press the (ENCODER) key or the (NEXT) key to confirm.

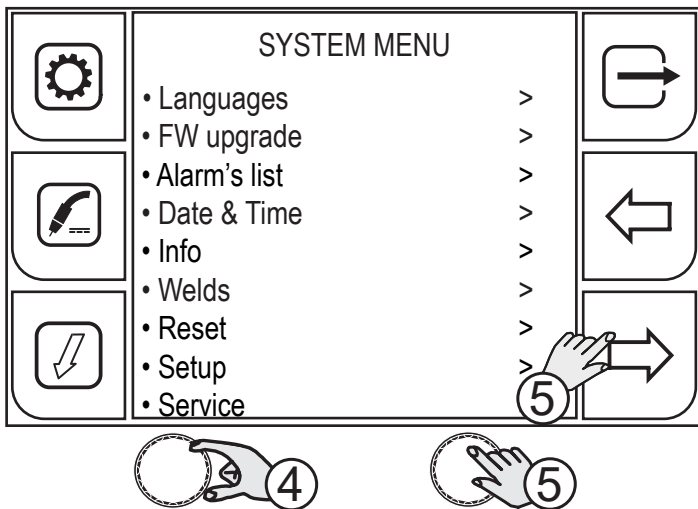

4. Turn the encoder to select the desired setting. Select the following path: Setup>
5. Press the (ENCODER) key or the (NEXT) key to confirm.

4.4.1 SETTING UP THE WIRE FEED

The WIRE FEED parameter allows the user to set up the wire insertion speed to be applied when the (INSERTION) key is pressed.

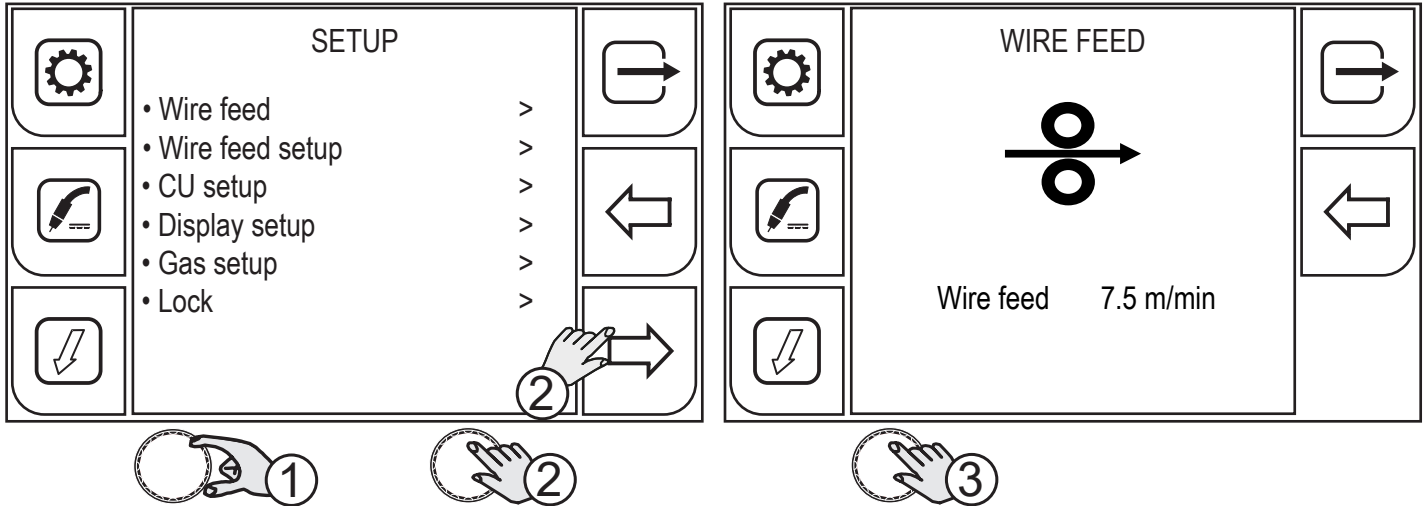

1. Turn the encoder to select the desired setting. Select the following path: Wire feed>
2. Press the (ENCODER) key or the (NEXT) key to confirm.
3. Press the (ENCODER) key to apply the parameter change.

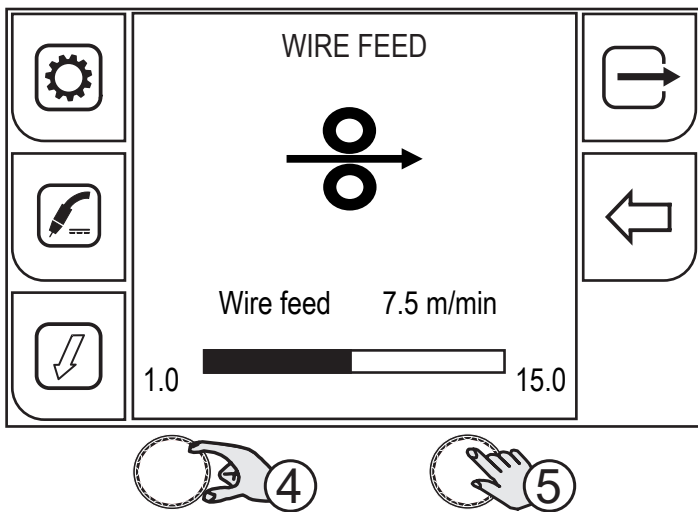

4. Turn the encoder to set the desired value.
5. Press the (ENCODER) key or the (NEXT) key to confirm.

To exit the screen, press the  key.

4.4.2 WIRE FEEDER SETUP

Enable when a WF-205p wire feeder is installed on a 405dms-505dms generator.

WIRE FEEDER SET UP enables the reception of commands from potentiometers of an external wire feeder unit.

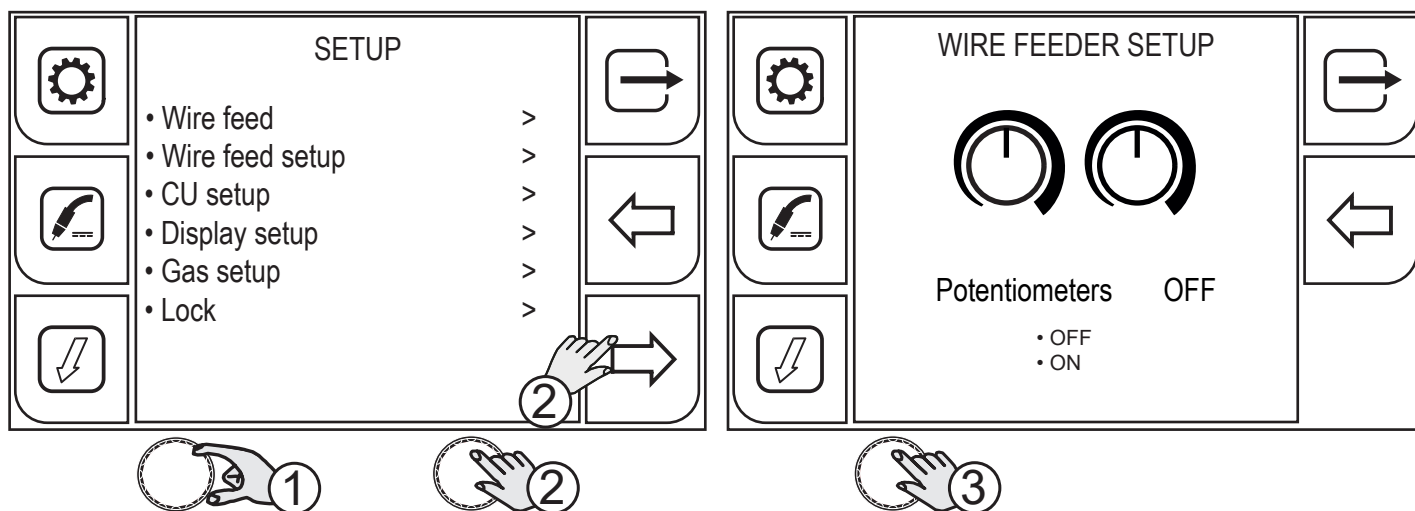

1. Turn the encoder to select the desired setting. Select the following path: Wire Feeder setup>
2. Press the (ENCODER) key or the (NEXT) key to confirm.
3. Press the (ENCODER) key to apply the parameter change.

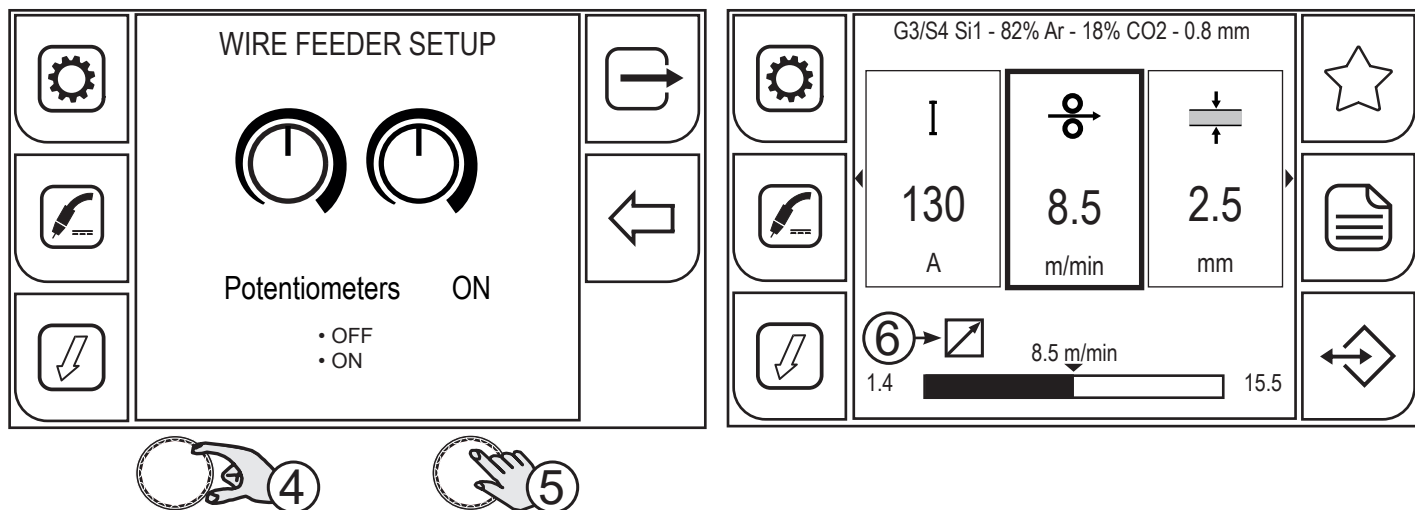

4. Turn the encoder to set the desired value.
5. Press the (ENCODER) key or the (NEXT) key to confirm.

To exit the screen, press the key.

6. The symbol (REMOTE) appears on the main screen when parameters which can be set by the wire feeder potentiometers are selected.

POT1 regulates the adjustment of parameters (wire speed/ampere/tension/material thickness) with respect to values preset from the synergic curve.

POT2 regulates the welding arc length correction in relation to the preset value from the synergic curve.

4.4.3 COOLING UNIT SETUP

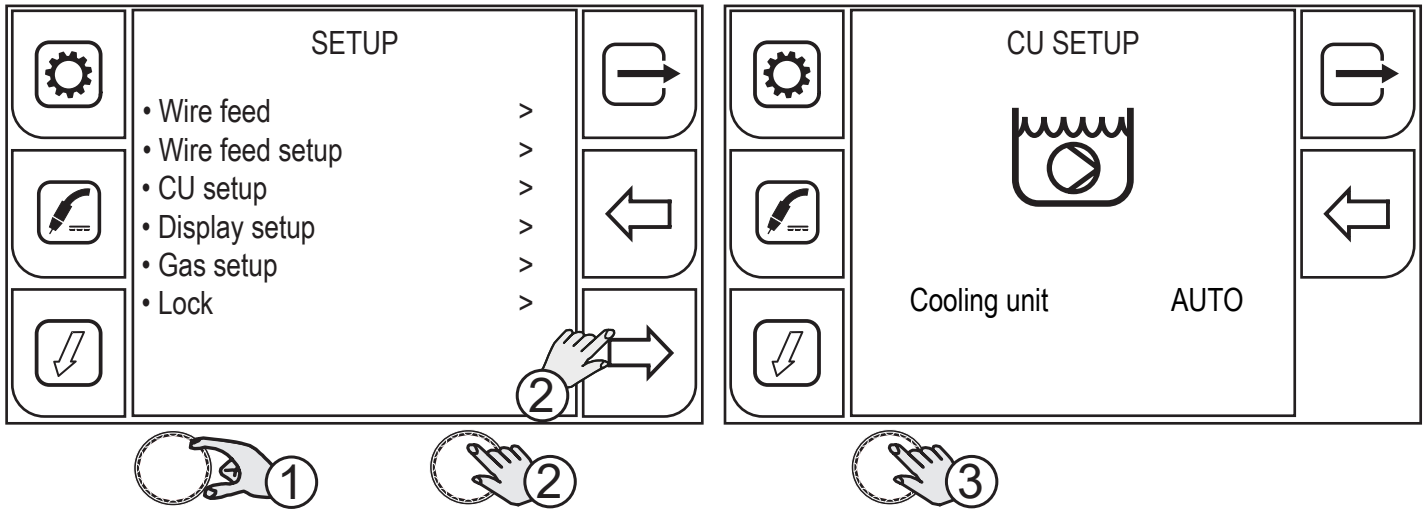

1. Turn the encoder to select the desired setting. Select the following path: CU setup>
2. Press the (ENCODER) key or the (NEXT) key to confirm.
3. Press the (ENCODER) key to apply the parameter change.

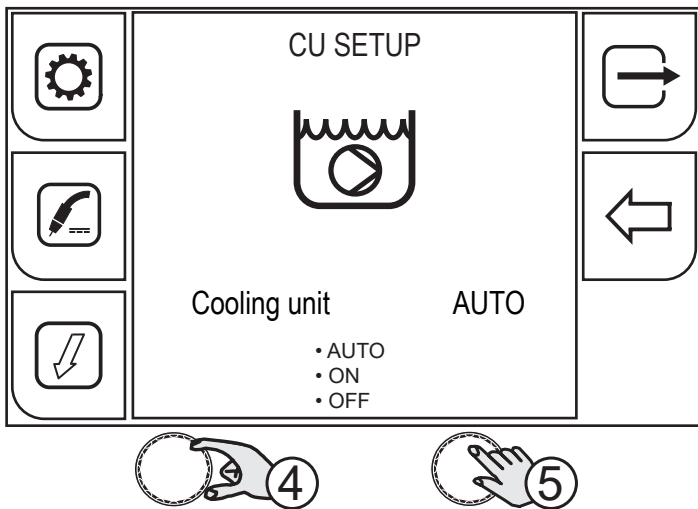

4. Turn the encoder to select the desired setting.
5. Press the (ENCODER) key to confirm your selection.

To exit the screen, press the  key.

- **AUTO:** When the welder is switched on, the unit is switched on for 30 s. During the welding operations, the unit runs continuously. When the welding operation is completed, the unit will stay on for 90 s plus a number of seconds related to the welding average current value.
- **ON:** The cooling unit is always on when the current generator is also switched on. This mode is preferable for heavy duty and automatic welding procedures.
- **OFF:** The cooling unit is always off; this function must be selected if an air cooled torch is used.

4.4.4 DISPLAY SETUP

The display setup option allows the user to select the parameters to be displayed in the main screen and the order in which they are displayed.

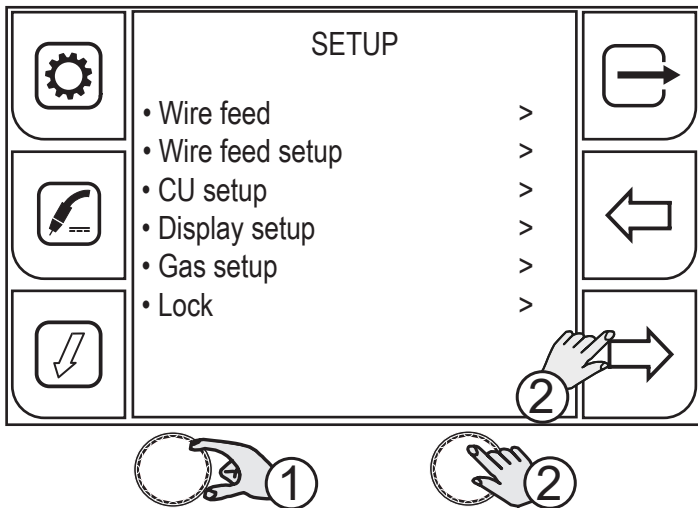
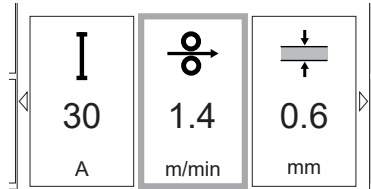

1. Turn the encoder to select the desired setting. Select the following path: Display setup>
2. Press the (ENCODER) key or the (NEXT) key to confirm.

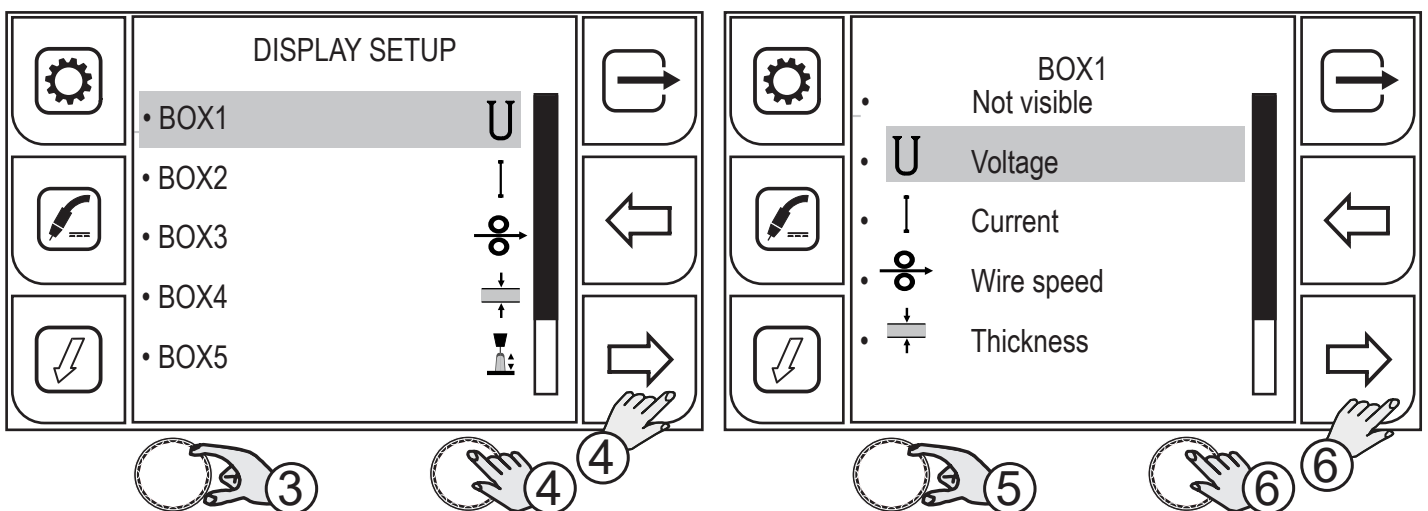

3. Turn the encoder to select the desired box.
4. Press the (ENCODER) key or the (NEXT) key to confirm.
5. Turn the encoder to select the desired parameter.
6. Press the (ENCODER) key or the (SAVE) key to confirm.

To exit the screen, press the key.

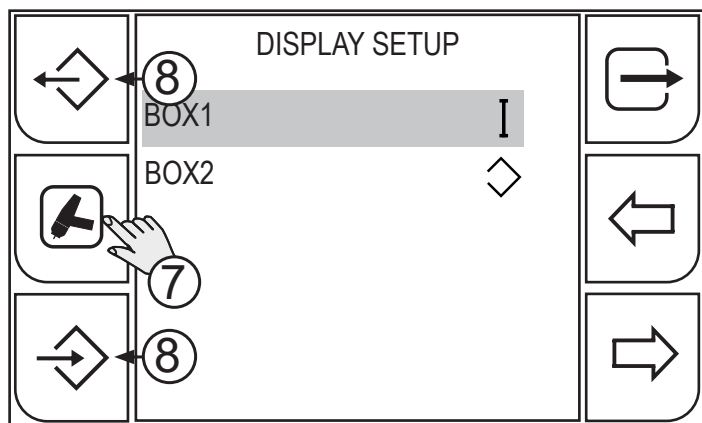

7. The display setup screen is associated with the welding process. Press repeatedly the process key to scroll the various welding process setup screens.
8. Personalised display setups can be exported or imported by means of the export/import keys. (See chapter "4.4.8 IMPORT / EXPORT" on page 42)

4.4.5 PUSH PULL SETUP

	INFORMATION!
<i>This menu item is always present. Nevertheless, in order to use the PushPull torch, you must first install the PushPull kit in the wire feeder).</i>	

You can install a PushPull torch. When you want to enable the PushPull torch motor command, you must enable this function.

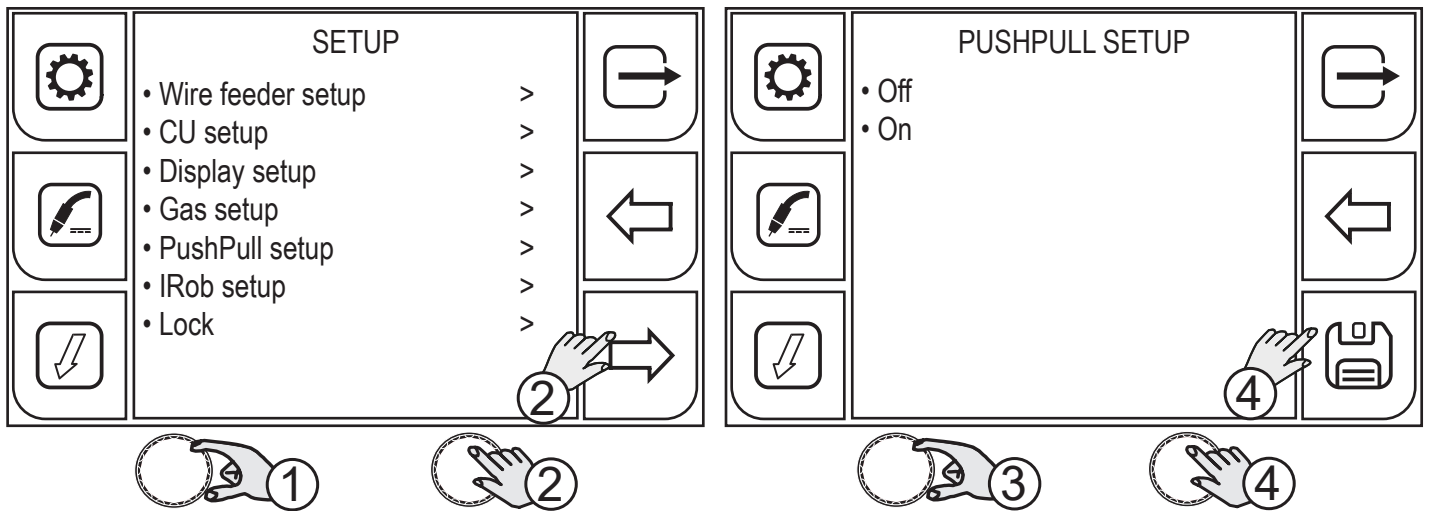

1. Turn the encoder to select the desired setting. Select the following path: PushPull> setup
2. Press the (ENCODER) key or the (NEXT) key to confirm.
3. Turn the encoder to select the desired setting.
4. Press the (ENCODER) key or the (SAVE) key to confirm.

Press the key  to exit the screen.

4.4.6 ROBOT INTERFACE SETUP

	INFORMATION!
<i>This menu item appears only in the generators set up to connect to a system for ROBOT applications.</i>	

The IROB SETUP menu lists the available communication interface types. This menu is used to configure the parameters for communication between the generator and the ROBOT. On the basis of the type of communication used, different types of setting are necessary that can be actuated via the various submenus.

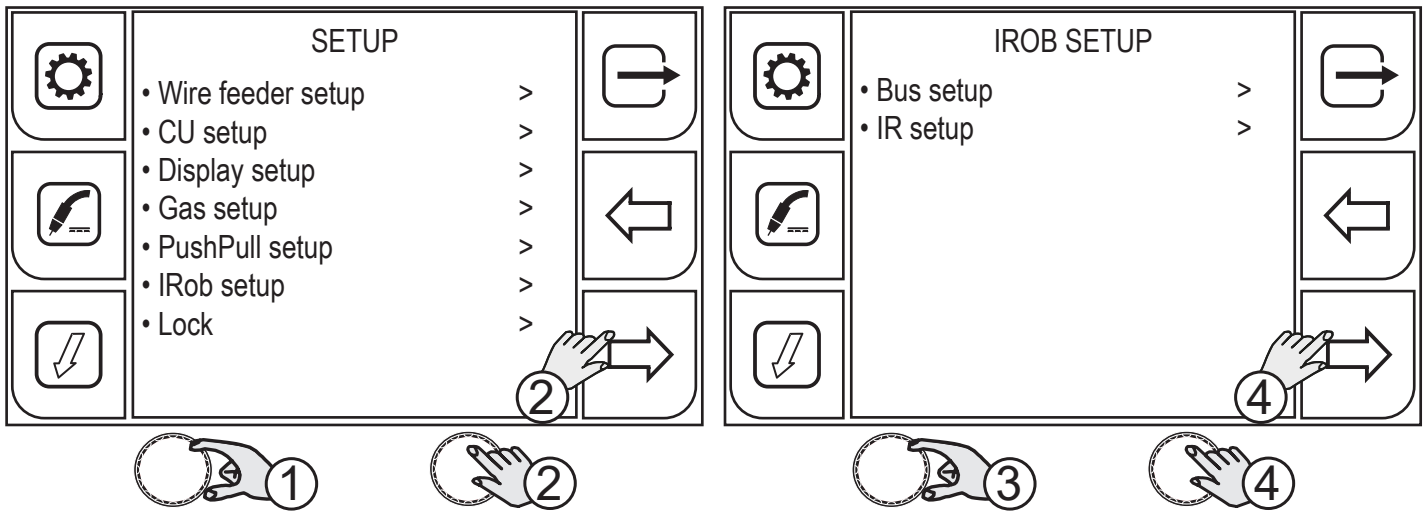

1. Turn the encoder to select the desired setting. Select the following path: IRob Setup>
2. Press the (ENCODER) key or the (NEXT) key to confirm.
3. Turn the encoder to select the desired setting.
4. Press the (ENCODER) key or the (NEXT) key to confirm.

Press the key  to exit the screen.

The data for configuring the network interface must be keyed in on the alphanumeric keypad.

 The touchscreen panel allows the user to set up the functions through the mechanical keys or by touching the icons displayed on the screen.

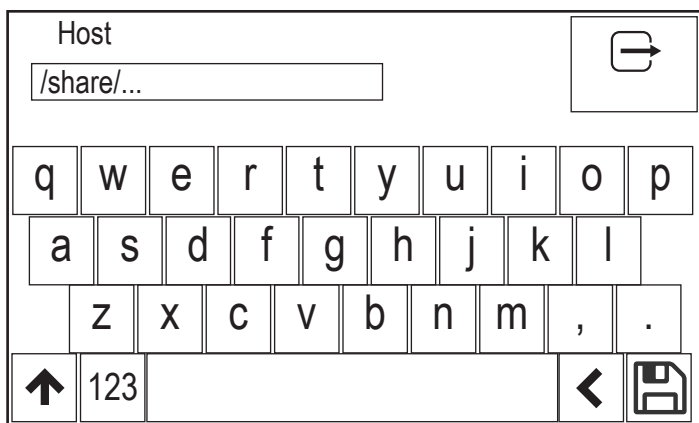
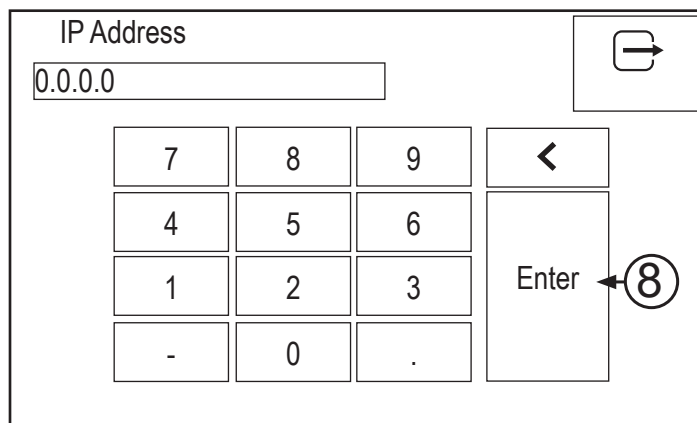
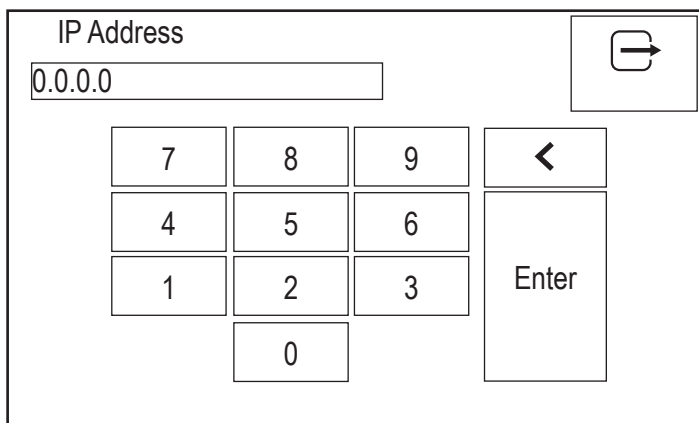

5. Turn the encoder to select the letter on the keyboard.
6. Press the (ENCODER) key to confirm your selection.
7. Turn the encoder to select the (SAVE)/(ENTER) symbol on the keyboard
8. Press the (ENCODER) key to save and exit.

Press the key  to exit without saving.

○ **BUS SETUP**

- Enter manually the parameters for communicating with field bus network. The parameters change according to the communication module used.
Set the following values for the bus bars that communicate via IP: (Host, Dhcp, Ip, Sub. mask, Gateway, Dsn1, Dsn2).
Set the following values for the serial bus bars: (address, baud rate).

○ **IR SETUP**

- Link info. Show the set and currently active values.
- Lan setup. Enter manually the parameters for communicating with LAN network. Set the values for the following parameters: (Dhcp, Ip, Sub. mask, Gateway, Dsn1, Dsn2).
- Wi-Fi setup scan: scans for Wi-Fi networks and shows the list of those present that can be associated with the device.

- Settings: enter manually the parameters for communicating by Wi-Fi. Set the values for the following parameters: (Dhcp, Ip, Sub. mask, Gateway, Dsn1, Dsn2).



INFORMATION!

Dynamic Host Configuration Protocol (DHCP), indicates a protocol that enables the devices of a local network to automatically receive the IP setup needed to establish a connection.

Set menu item "DHCP" to "On" to detect and automatically set the network connection values.

4.4.7 LOCK (LOCK/UNLOCK THE CHANGES)

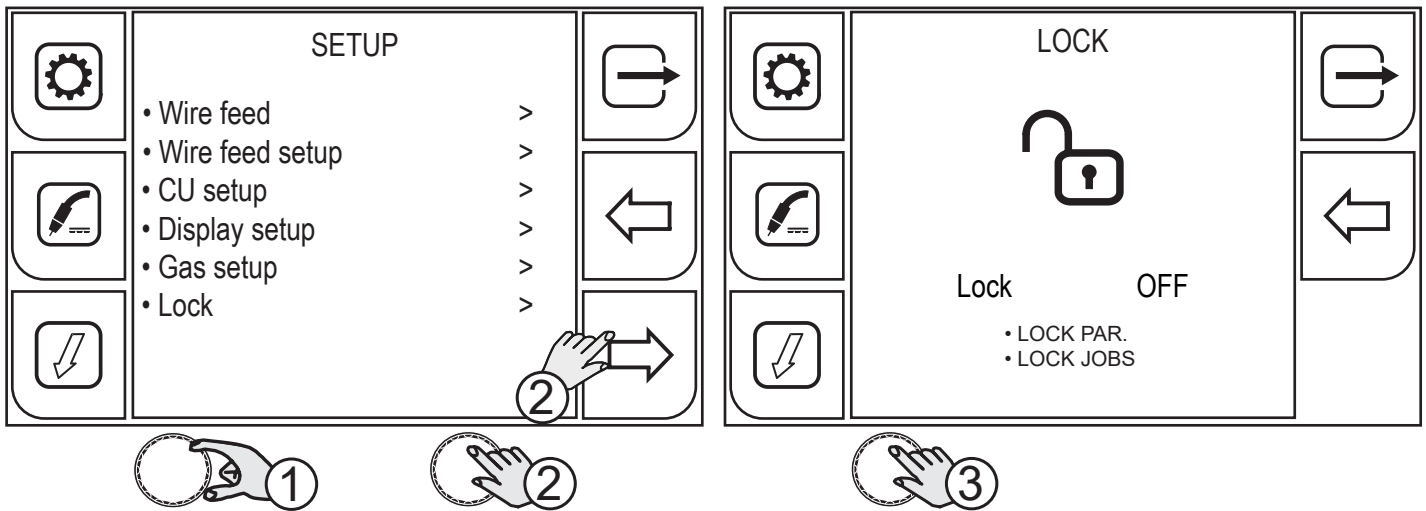

1. Turn the encoder to select the desired setting. Select the following path: Lock>
2. Press the (ENCODER) key or the (NEXT) key to confirm.
3. Press the (ENCODER) key to apply the parameter change.

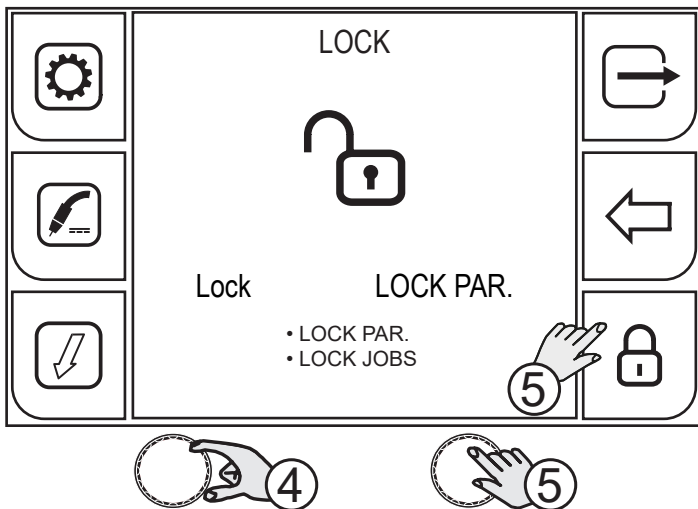

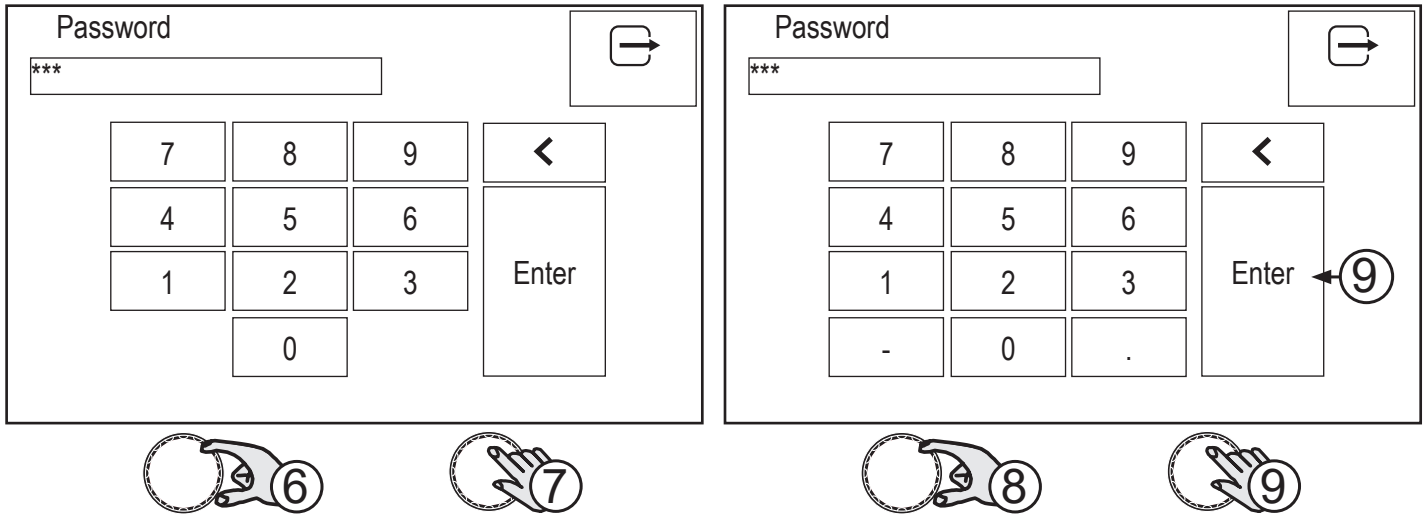

4. Turn the encoder to select the desired setting.
 - **LOCK PAR.:** lock all parameters change with the exclusion of arc correction, torch button mode.
 - **LOCK JOBS:** lock the jobs parameter change; it is possible to scroll and load saved jobs.
5. Press the (ENCODER) key to confirm or the (NEXT) key.

To exit the screen, press the key.



Enter a 3-digit password. Make a note of the saved password as it can't be deleted prior to delete the stored settings and jobs.

 The touchscreen panel allows the user to set up the functions through the mechanical keys or by touching the icons displayed on the screen.

6. Turn the encoder to select the number on the keyboard.
7. Press the (ENCODER) key to confirm your selection.
8. Turn the encoder to select the (ENTER) symbol on the keyboard.
9. Press the (ENCODER) key to confirm your selection. To exit the screen, press the  key.

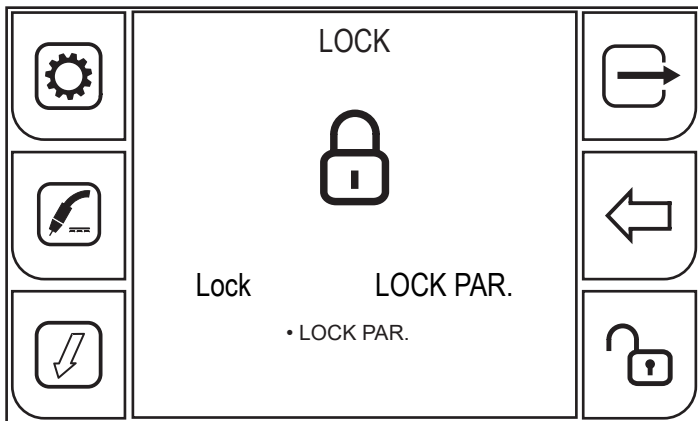

The closed padlock symbol means changes lock is activated for the chosen setting.

To unlock the changes, enter the LOCK screen.

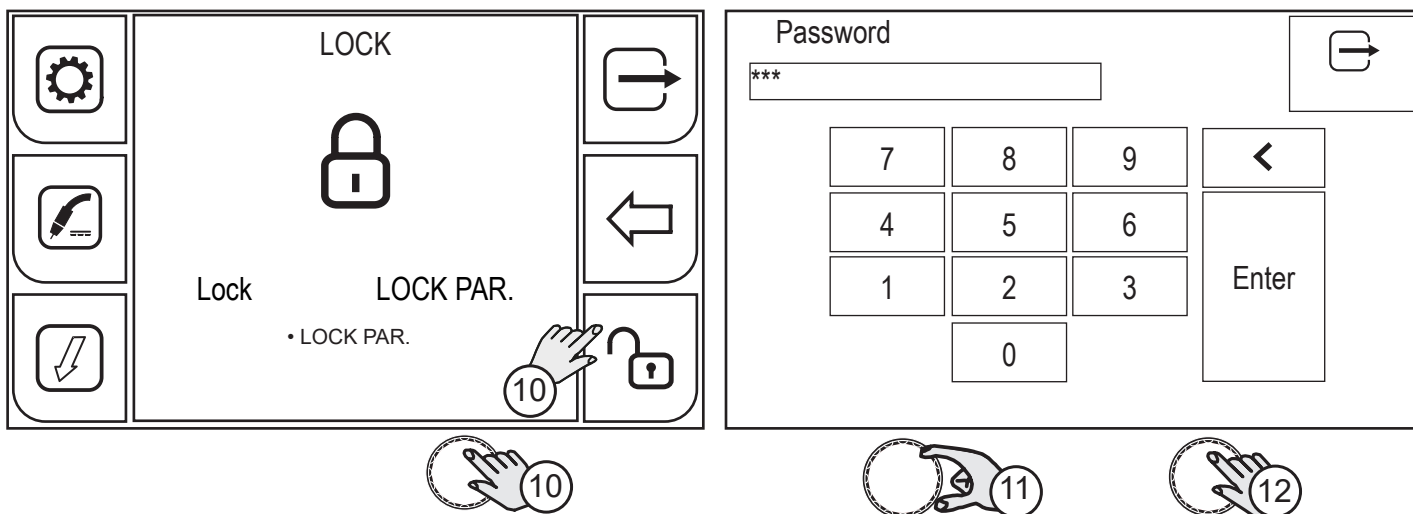

10. Press the (ENCODER) key to confirm or the (NEXT) key.
Enter the 3-digit password.

 The touchscreen panel allows the user to set up the functions through the mechanical keys or by touching the icons displayed on the screen.

11. Turn the encoder to select the number on the keyboard.

12. Press the (ENCODER) key to confirm your selection.

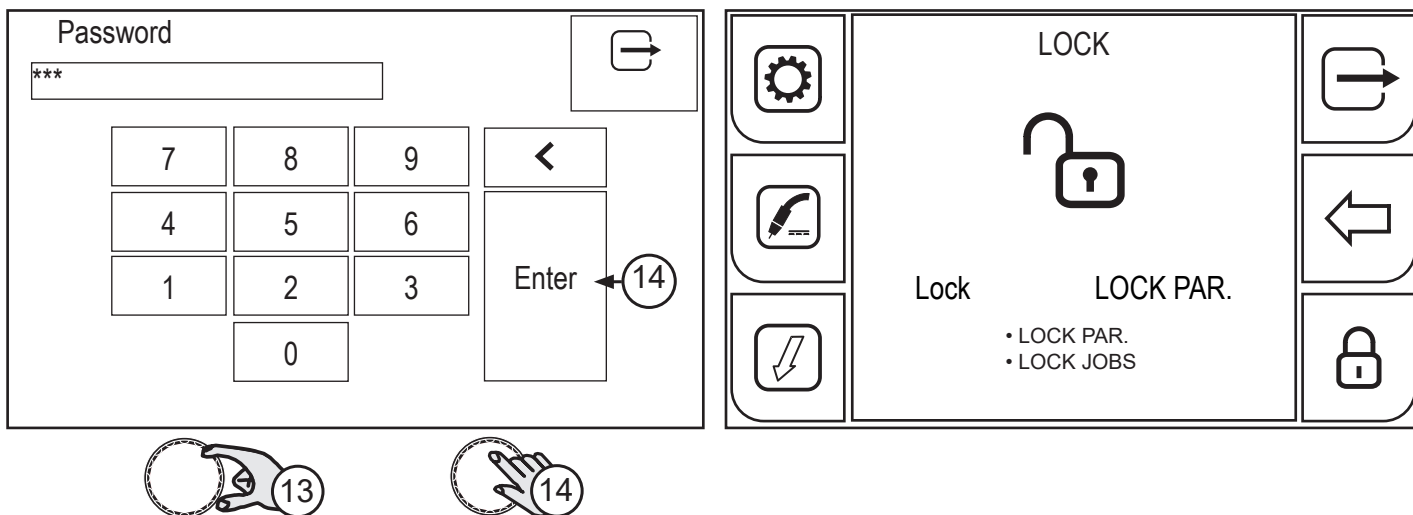

13. Turn the encoder to select the (ENTER) symbol on the keyboard.

14. Press the (ENCODER) key to confirm your selection. To exit the screen, press the  key.
The open padlock symbol means changes lock is deactivated.

4.4.8 IMPORT / EXPORT

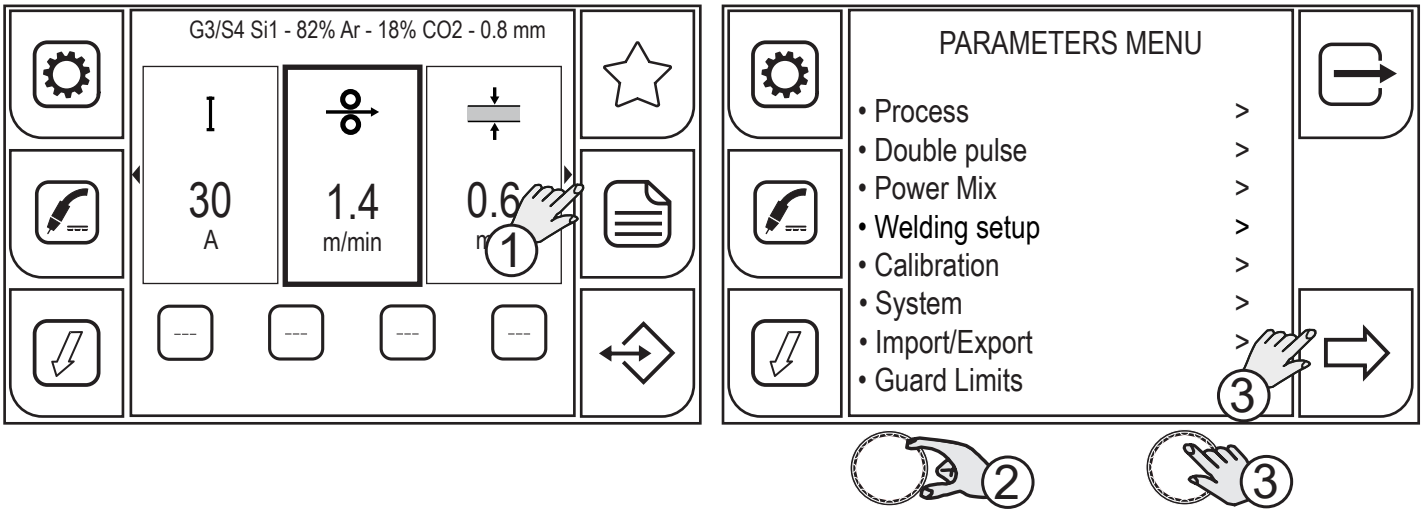

1. Press the (MENU) key.
2. Turn the encoder to select the desired setting. Select the following path: Import/Export>
3. Press the (ENCODER) key or the (NEXT) key to confirm.

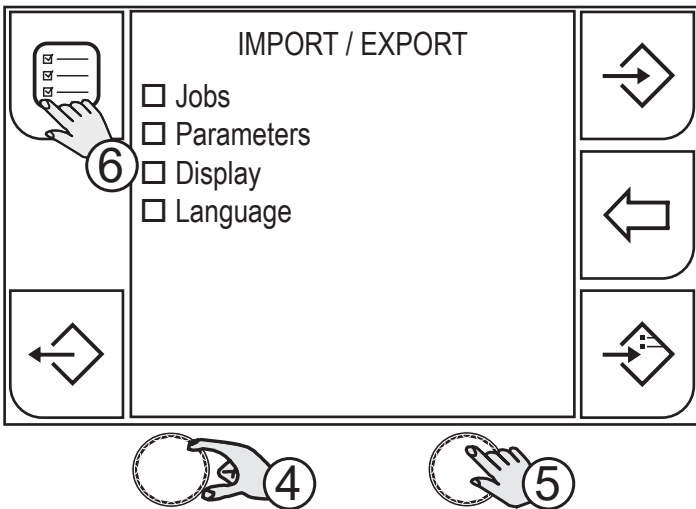

4. Turn the encoder to select the desired setting.
 - Jobs: jobs are imported/exported, only
 - Parameters: unit operating parameters are imported/exported, only
 - Display: display setup is imported/exported, only
 - Language
5. Press the (ENCODER) key to confirm.
6. If you wish to select/deselect all the boxes, press the (SELECT ALL) / (DESELECT ALL) key.

EXPORT

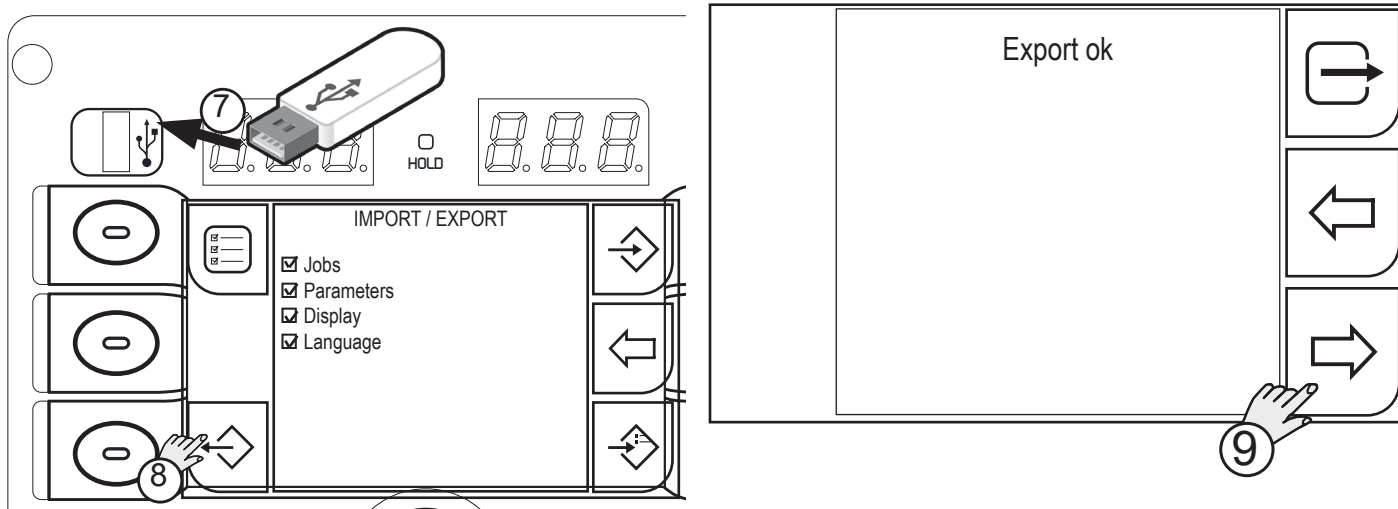

7. Insert the USB memory stick in the port provided.
8. Press the (EXPORT) key to export the files to the USB memory stick. If the exporting operation is successful, the message “Export OK” will appear.
9. Press the (SI) key

Press the ← (NO) key to return to the previous screen.

To return to the main screen, press the → (EXIT) key.

IMPORT

Press the (IMPORT) key to import the files and jobs saved onto the USB memory stick.

If the JOB files are stored on the USB memory stick in the same position (number before name) as the files located in the WF-205, the latter will be overwritten by the files saved on the memory stick.

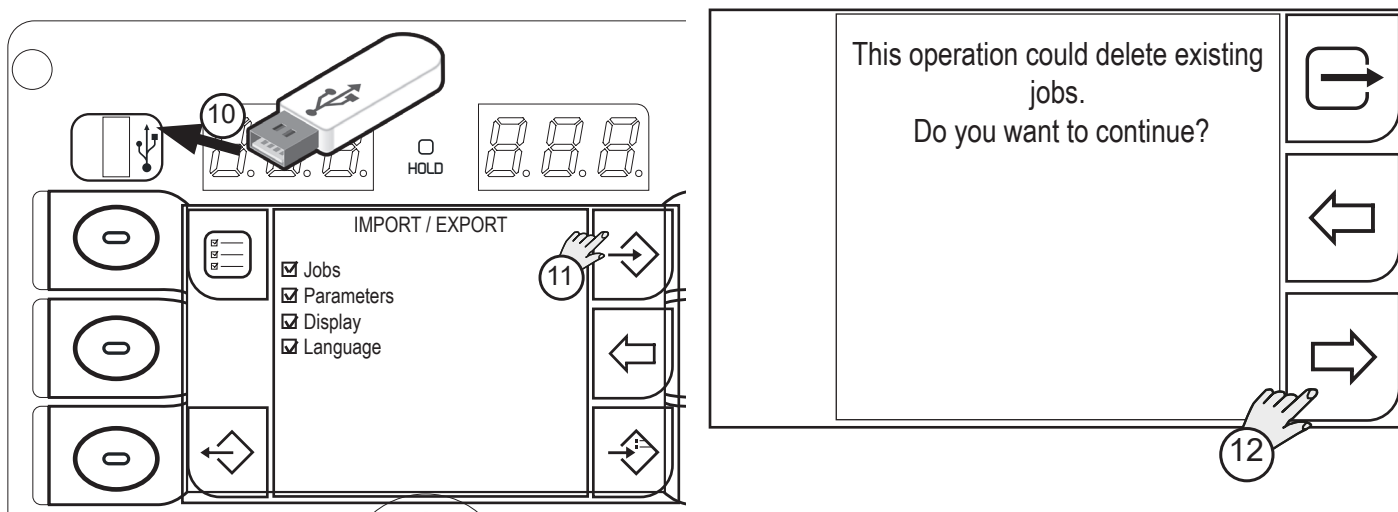

10. Insert the USB memory stick in the port provided.
11. Press the (IMPORT) key to import the files to the USB memory stick.
12. Press the (SI) key to confirm.

Press the ← (NO) key to return to the previous screen.

To return to the main screen, press the → (EXIT) key.

ADD

Press the (ADD) key to add to the JOBS located on the WF-205 the files saved on the USB memory stick. The files located on the USB memory stick will be added to the files located on the WF-205, renumbering and adding them at the bottom of the list.

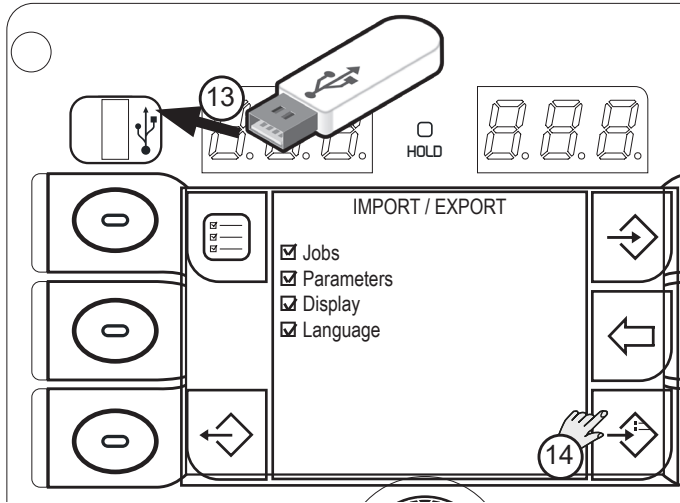

- 13. Insert the USB memory stick in the port provided.
- 14. Press the (ADD) key to import the files to the USB memory stick.

Press the ← (PREC) key to return to the previous screen.

4.4.9 WIRE FEEDER SET UP

☞ Enable when a WF-205p wire feeder is installed on a 405dms-505dms generator.

WIRE FEEDER SET UP enables the reception of commands from potentiometers of an external wire feeder unit. Wire feeder set up is not requested for this equipment.

4.4.10 SETTING UP THE GUARD LIMITS

Some guard limits for specific parameters may be set up; when reached, the generator will:

- give a WARNING and continue to carry out the welding operations;
- give an ALARM and stop all welding operations.

The warnings may be reset directly from the warning screen by pressing OK.

The screen displays a message showing the type of limit exceeded. If these limits are exceeded, the log screen will be displayed.

ENABLING THE GUARD LIMITS

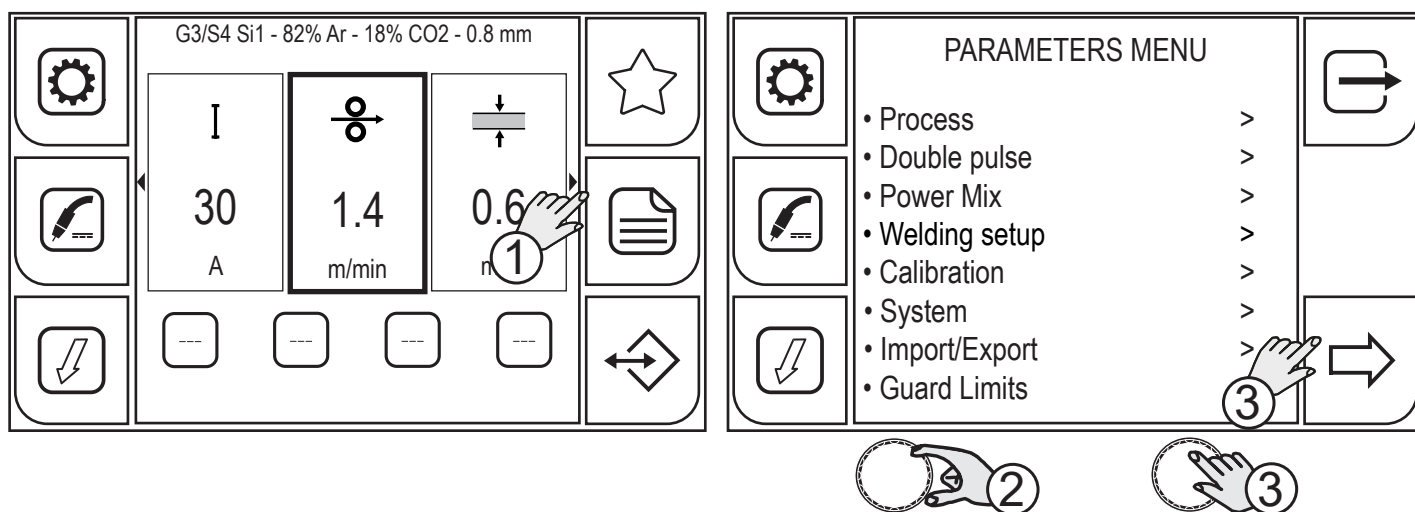

1. Press the (MENU) key.
2. Turn the encoder to select the desired setting. Select the following path: Guard limits>
3. Press the (ENCODER) key or the (NEXT) key to confirm.

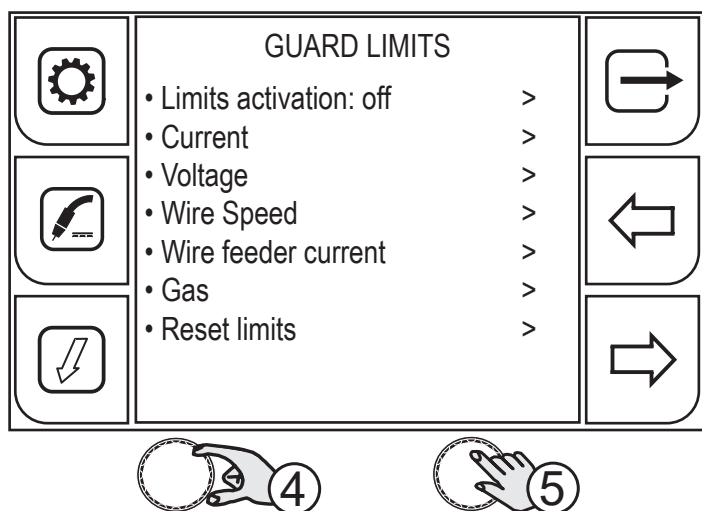

4. Turn the encoder to select the desired setting. Select the following path: Limits activation>
5. Press the (ENCODER) key or the (NEXT) key to confirm.

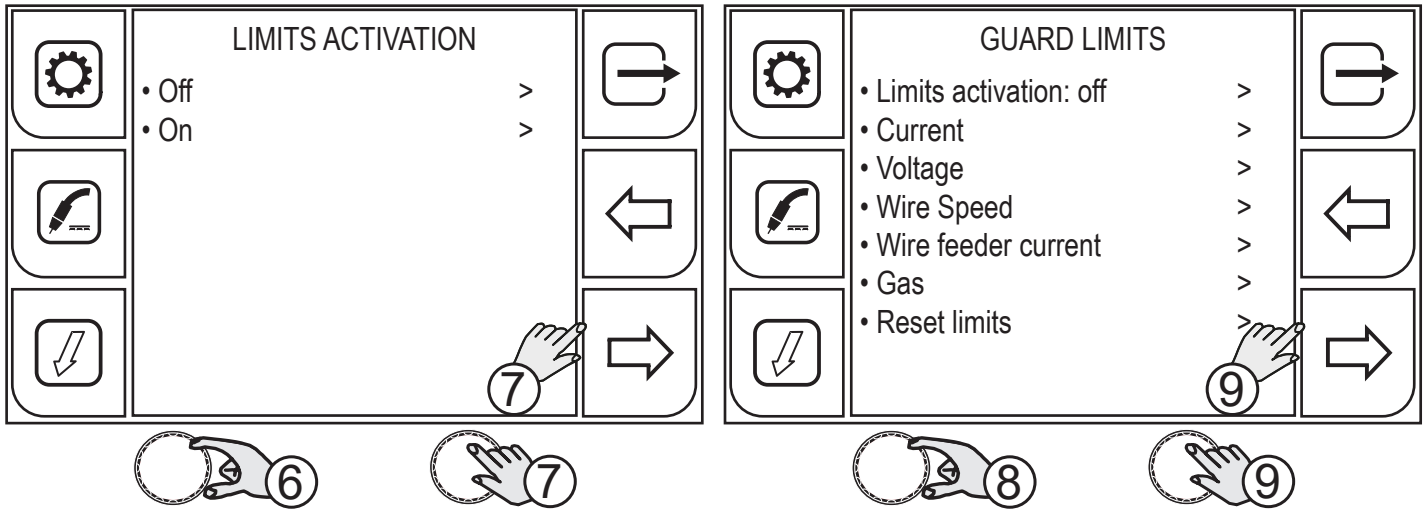

6. Turn the encoder to select the desired setting. Select the following path: On
7. Press the (ENCODER) key or the (NEXT) key to confirm.
8. Turn the encoder to select the parameter to be enabled.
(GUARD LIMITS: Current, Voltage, Wire speed, Wire feeder current, Gas)
9. Press the (ENCODER) key or the (NEXT) key to confirm.

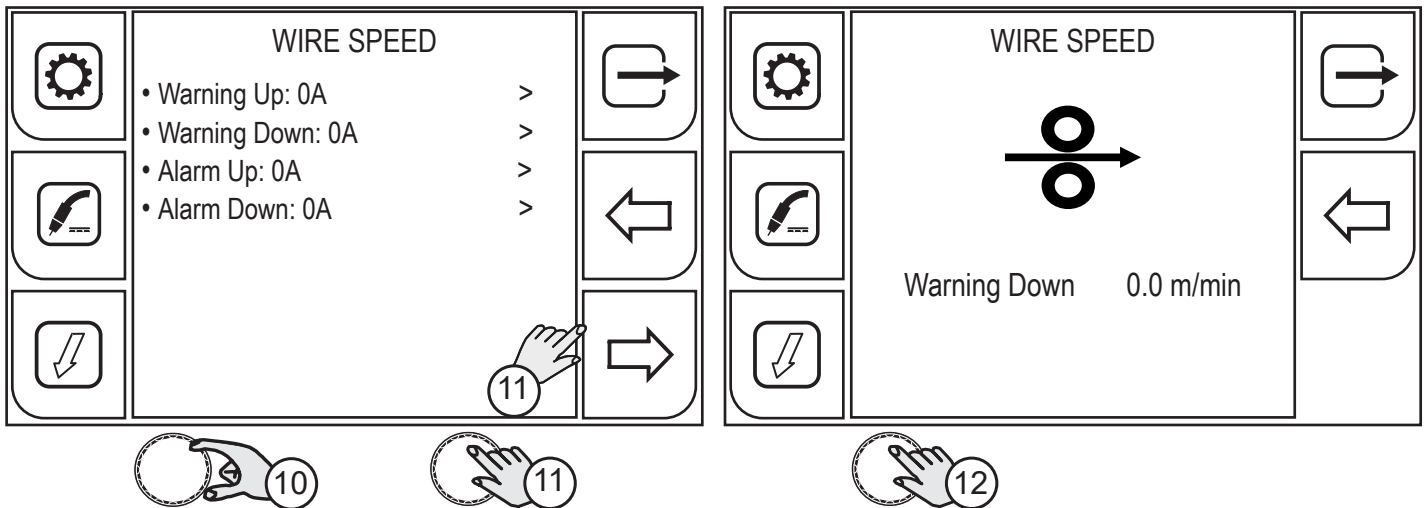

Settable thresholds for each parameter:

- Warning Up: upper warning threshold (a warning is displayed on the screen)
- Warning Down: lower warning threshold (a warning is displayed on the screen)
- Alarm Up: upper alarm threshold (the welding operation is stopped)
- Alarm Down: lower alarm threshold (the welding operation is stopped)

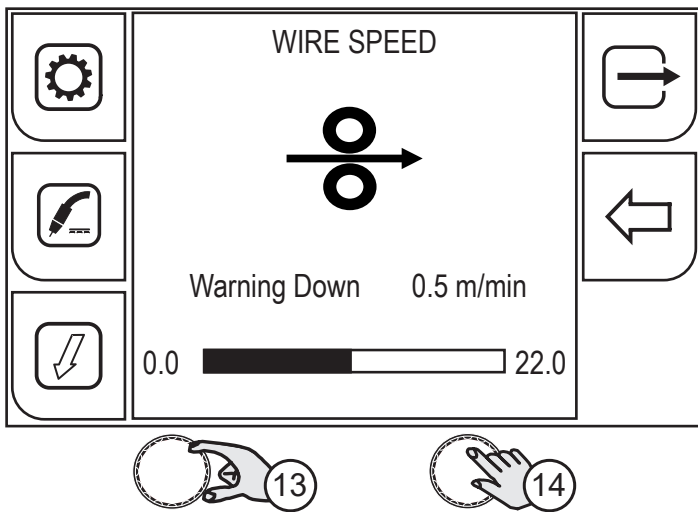

10. Turn the encoder to select the type of threshold.
11. Press the (ENCODER) key or the (NEXT) key to confirm.
12. Press the (ENCODER) key to apply the parameter change. When the threshold is set to 0, the parameter is disabled.



13. Turn the encoder to set the desired value.
 14. Press the (ENCODER) key to confirm your selection.
- Press the  (PREV) key to return to the previous screen.
- Press the  (EXIT) key to go back to the home page.

RESETTING THE GUARD LIMITS

This function sets to 0 the thresholds of all the guard limits set.
The LIMITS ACTIVATION parameter status is not reset.

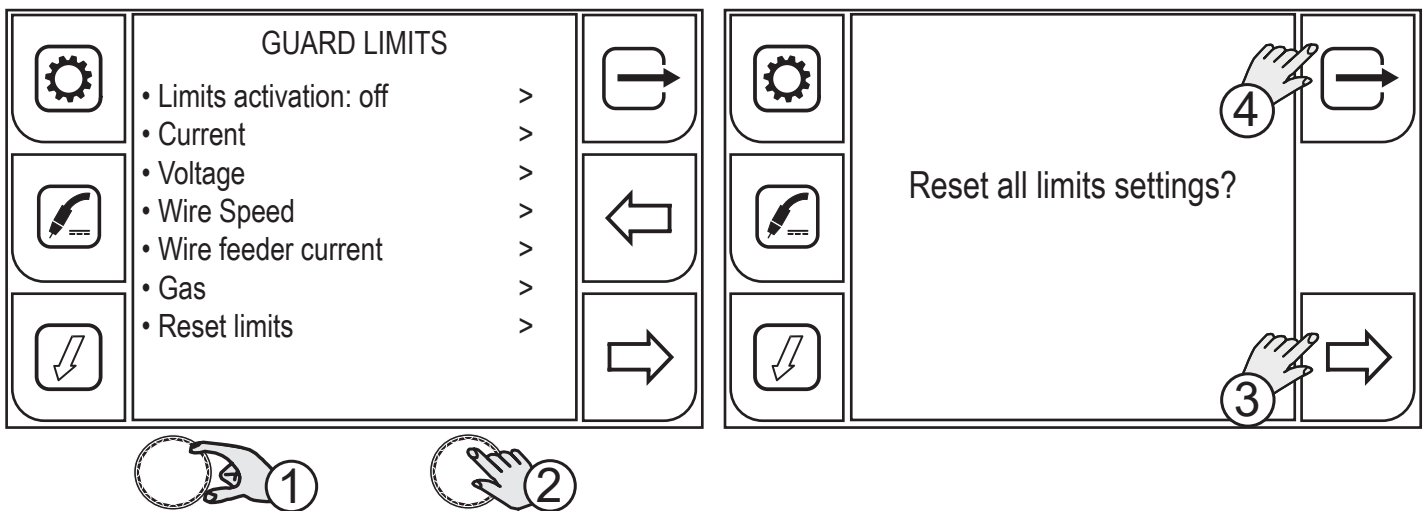

1. Turn the encoder to select the desired setting. Select the following path: Reset limits>
2. Press the (ENCODER) key or the (NEXT) key to confirm.
3. Press the (YES) key to confirm your selection.
4. Press the (NO) key to cancel your selection.

4.4.11 DOCUMENTATION

	INFORMATION!
<i>This menu item appears only in the generators set up to connect to a ROBOT system and if the "Industria 4.0" licence is active.</i>	

Use this menu to access the information screens relating to generator status.

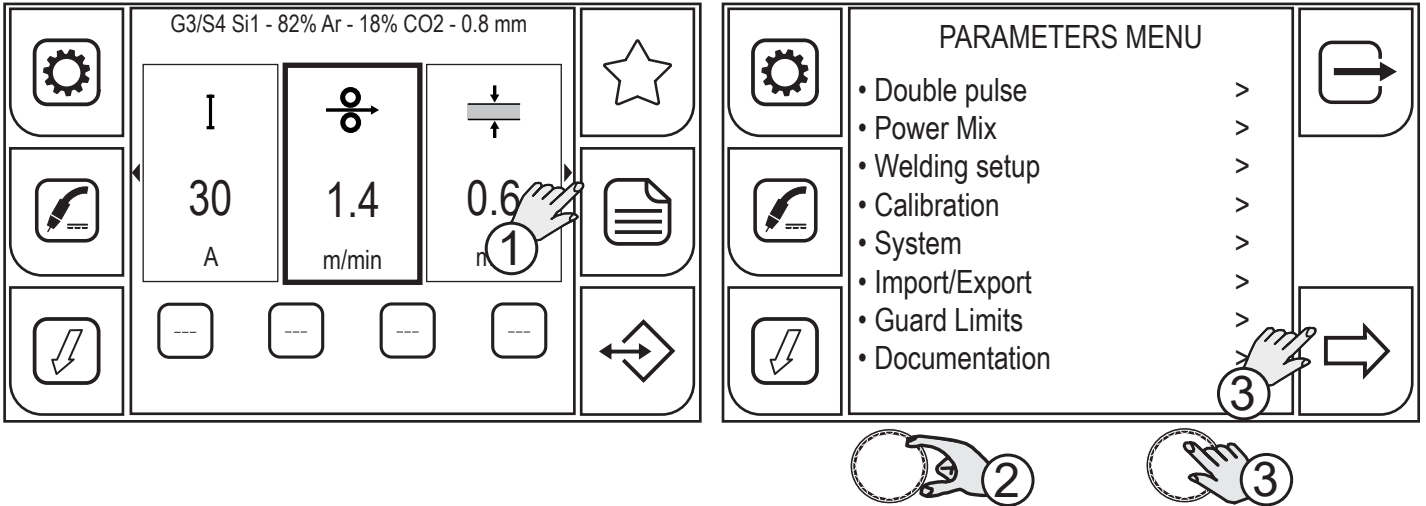

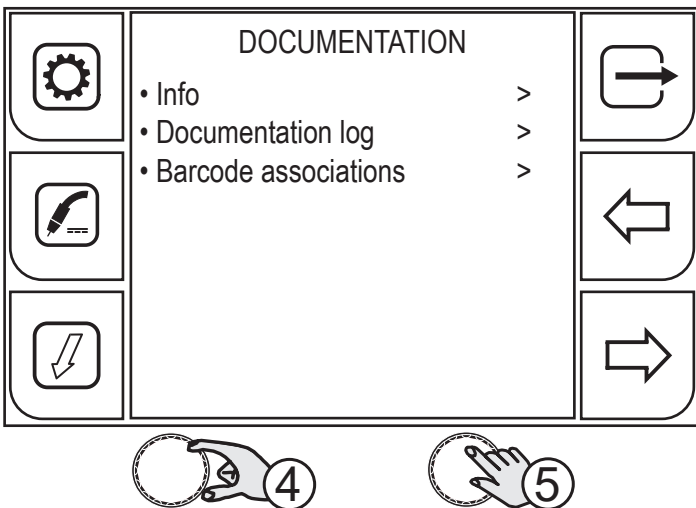

The diagram illustrates the navigation process. It starts with a main menu showing parameters: G3/S4 Si1 - 82% Ar - 18% CO2 - 0.8 mm, I 30 A, 1.4 m/min, and 0.6 n. A hand icon with a circled '1' points to the MENU key (represented by a document icon). This leads to the PARAMETERS MENU, which lists: Double pulse, Power Mix, Welding setup, Calibration, System, Import/Export, Guard Limits, and Documentation. A hand icon with a circled '2' points to the encoder, and a hand icon with a circled '3' points to the NEXT key (represented by a right arrow icon).

1. Press the (MENU) key.
2. Turn the encoder to select the desired setting. Select the following path: Documentation>
3. Press the (ENCODER) key or the (NEXT) key to confirm.





The diagram shows the DOCUMENTATION menu with the following options: Info, Documentation log, and Barcode associations. A hand icon with a circled '4' points to the encoder, and a hand icon with a circled '5' points to the NEXT key (represented by a right arrow icon).

4. Turn the encoder to select the desired setting.
5. Press the (ENCODER) key or the (NEXT) key to confirm.

Expire	Infinite	
Host	/share/MD0_DATA/homes	
User	Software	
Template	template1	
Title	Report	
Filename	WeldReport	
Path	C:\Users\simones\Desktop\WeldingReport	
N° welds	1	

Info: the information is shown on recording welding data by Data Manager software (licence, save path on server and computer, activated template, name of report, etc).

20/05/2022 08:30:25	REC Pause	
20/05/2022 08:30:23	REC Start	
20/05/2022 08:30:22	REC Pause	
20/05/2022 08:30:20	REC Start	
16/05/2022 09:07:50	Report Template: template1.xml	
13/05/2022 10:39:16	Report Template: template2.xml	
13/05/2022 10:39:01	Report Template: template1.xml	
13/05/2022 10:38:52	Report Template: template2.xml	
13/05/2022 10:38:51	Report Template: template1.xml	
12/05/2022 15:07:25	Report Template: PCtemplate1.xml	

Documentation log: shows the list of the tasks involved in creating the documentation (uploading templates, starting data recording, pausing data recording, etc ...) using Data Manager software.

803063	Code Group	Group 8030*	
8030631995324	Report Template	Report2.xml*	
8030631995323	Report Info	this text *	
8030631995323	Report Template	Report1.xml*	

Barcode associations: shows the list of the barcodes and what the barcodes are associated with. The associations are made by Data Manager software.

5 MIG/MAG WELDING

5.1 WELDING CIRCUIT CALIBRATION

By using the WELDING CIRCUIT CALIBRATION guided procedure, the resistance and inductance values of the welding circuit are measured. When the wire feeder is used with its cable harness, the welding circuit “r” resistance can be measured by using the calibration function. This allows to achieve a consistent welding quality when the cable harness length and the torch is changed. The welding circuit resistance depends on the cable harness and on the torch used; we therefore recommend that the calibration procedure is repeated when these components are changed. If a generator full RESET procedure is carried out, the default calibration value will be restored. If a partial RESET is carried out, the measured value will be stored. The calibration is not compulsory therefore, if the user decides not to carry it out, the machine will use the default value.

The generator must be on and not set up for welding.

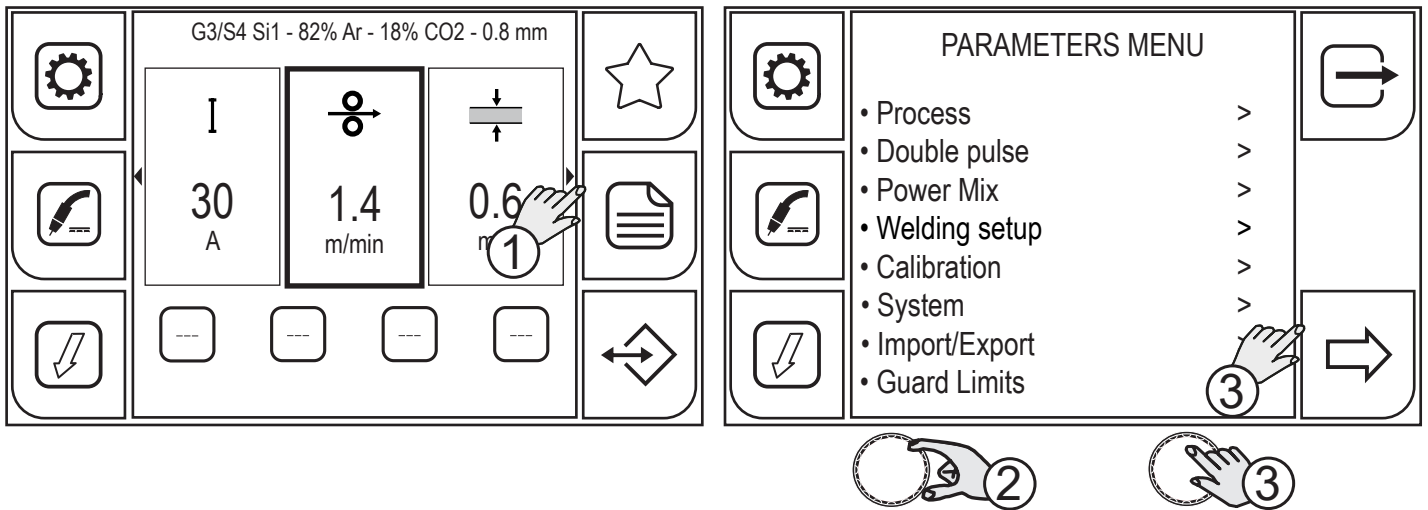

1. Press the (MENU) key.
2. Turn the encoder to select the desired setting. Select the following path: Calibration>
3. Press the (ENCODER) key or the (NEXT) key.

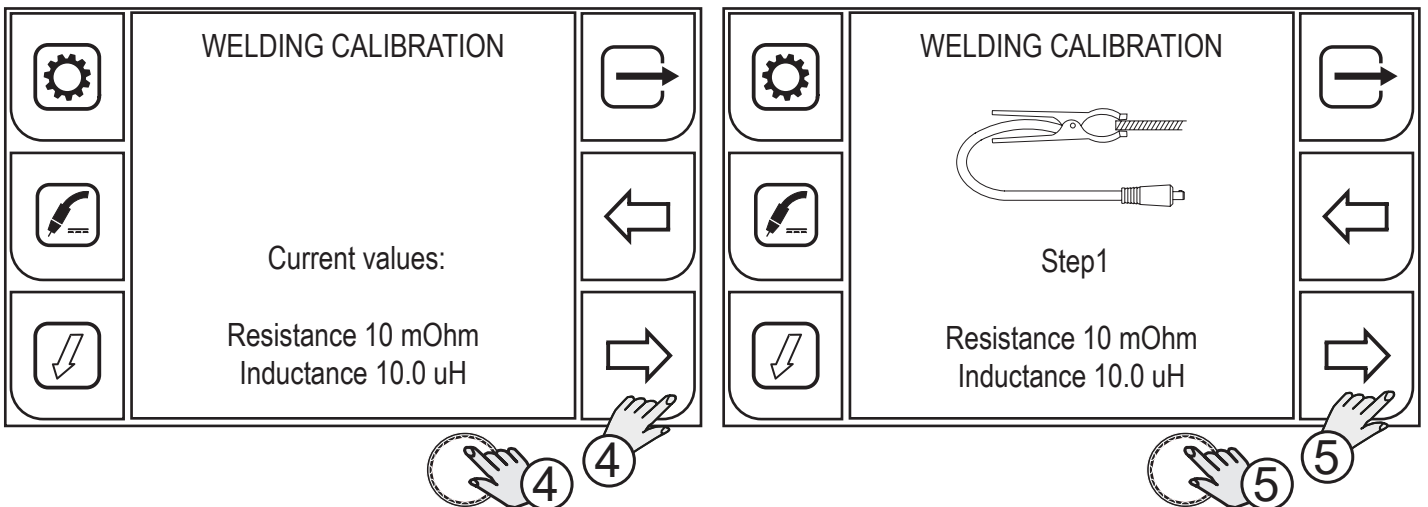

4. Press the (ENCODER) key or the (NEXT) key or the torch trigger to confirm.
5. Press the (ENCODER) key or the (NEXT) key or the torch trigger to confirm.

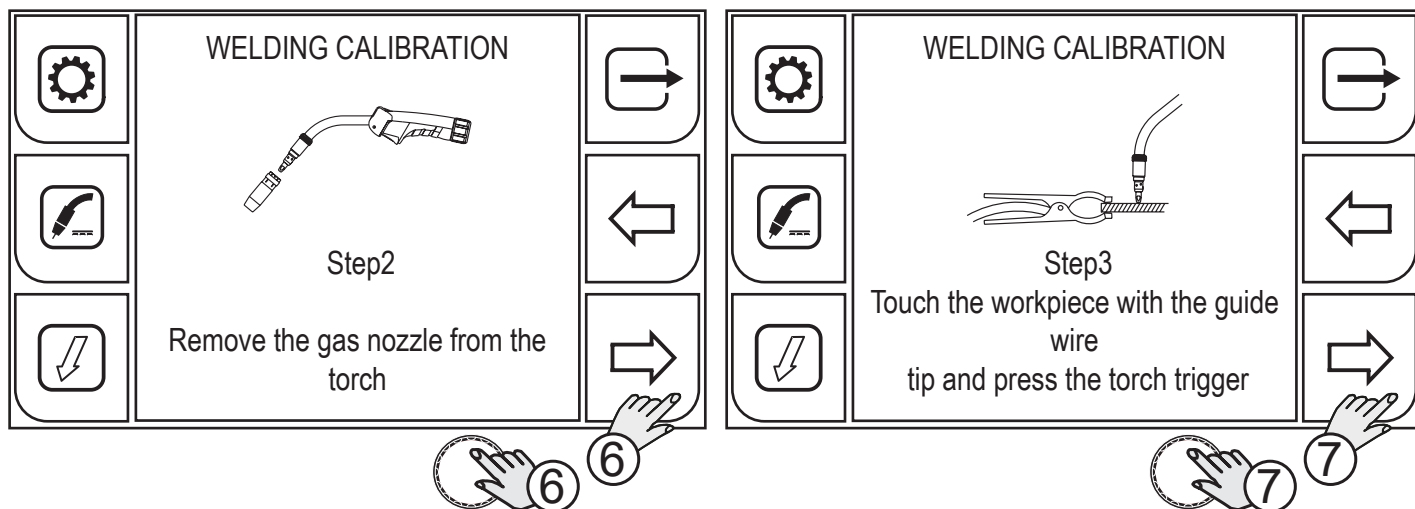

6. Press the (ENCODER) key or the (NEXT) key or the torch trigger to confirm.
7. Press the (ENCODER) key or the (NEXT) key or the torch trigger to confirm.

At the end of the procedure, the measured welding circuit resistance and inductance values will be displayed. By doing so, a consistent welding quality can be achieved when the length of the cable harness, of the earth cable and of the torch changes.

Should the measurement be unsuccessful, the "CALIBRATION ERROR" message will be displayed.

5.2 GAS FLOW REGULATION

5.2.1 VERSION WITHOUT FLOWMETER

When the unit is powered on, the solenoid valve is enabled for 1 second.
This fills the gas circuit.

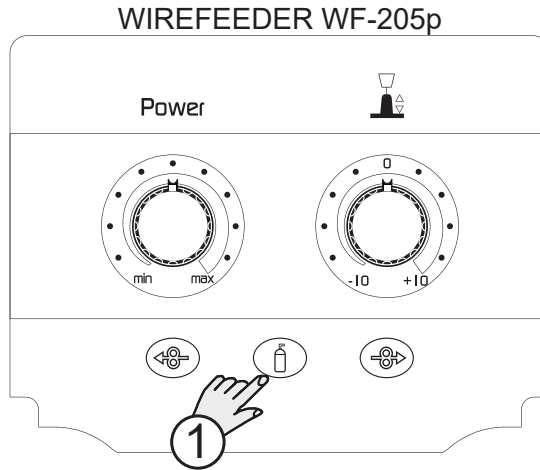

1. Open the gas solenoid valve by pressing and releasing the  (GAS) key.



2. Regulate the pressure of the gas flowing from the torch by means of the flow meter connected to the gas cylinder.

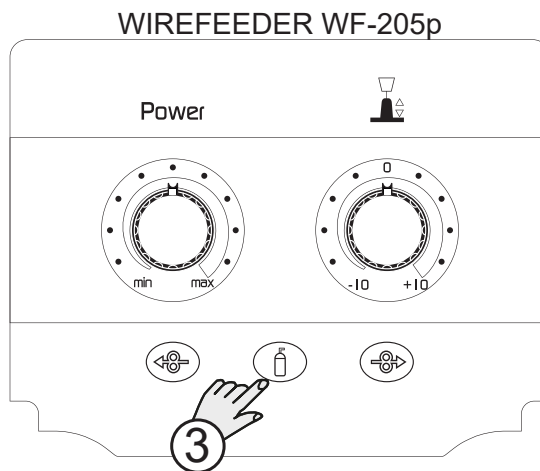

3. Close the gas solenoid valve by pressing and releasing the  (GAS) key.
The solenoid valve is automatically closed after 30 seconds.

5.2.2 VERSION WITH FLOWMETER

An external flowmeter can be installed (gas kit) to measure the flow rate (litre/minute) of gas used. When the flowmeter is installed, the gas measurement can be corrected by adjusting a coefficient.

The flow rate of gas used is automatically calculated according to the welding curve selected. If a specific gas is used (for example, a ternary gas or special mixtures) not included in the GAS MENU list, it may be necessary to correct the measurement by using the GAS SETUP parameter. The flow rate of the gas in the external flow meter must be read and the GAS SETUP must be adjusted so that the value displayed on the screen matches the value read in the gas flow meter.



To correctly measure the gas flow rate exiting the torch, we recommend that a gas flow meter is used, to be applied directly to the torch outlet.

- Open the gas solenoid valve by pressing and releasing the  (GAS) key.
- Read the gas flow rate detected by the gas flow meter.
- Follow the procedure described below to set up the gas flow meter correction.

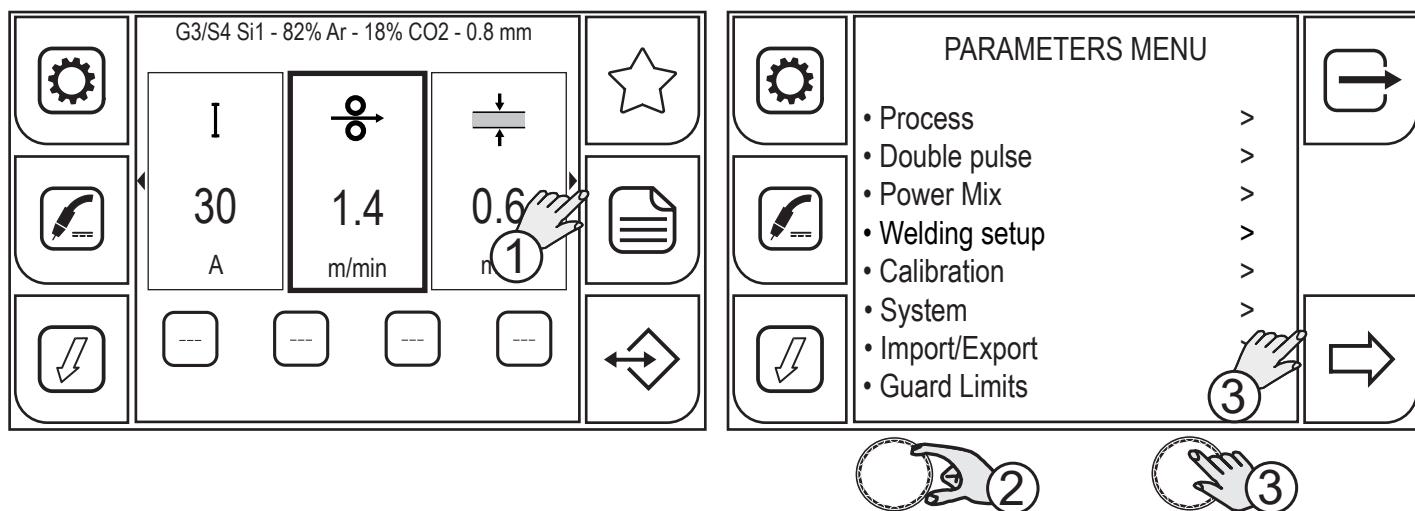

1. Press the (MENU) key.
2. Turn the encoder to select the desired setting. Select the following path: System>
3. Press the (ENCODER) key or the (NEXT) key to confirm.

ENGLISH

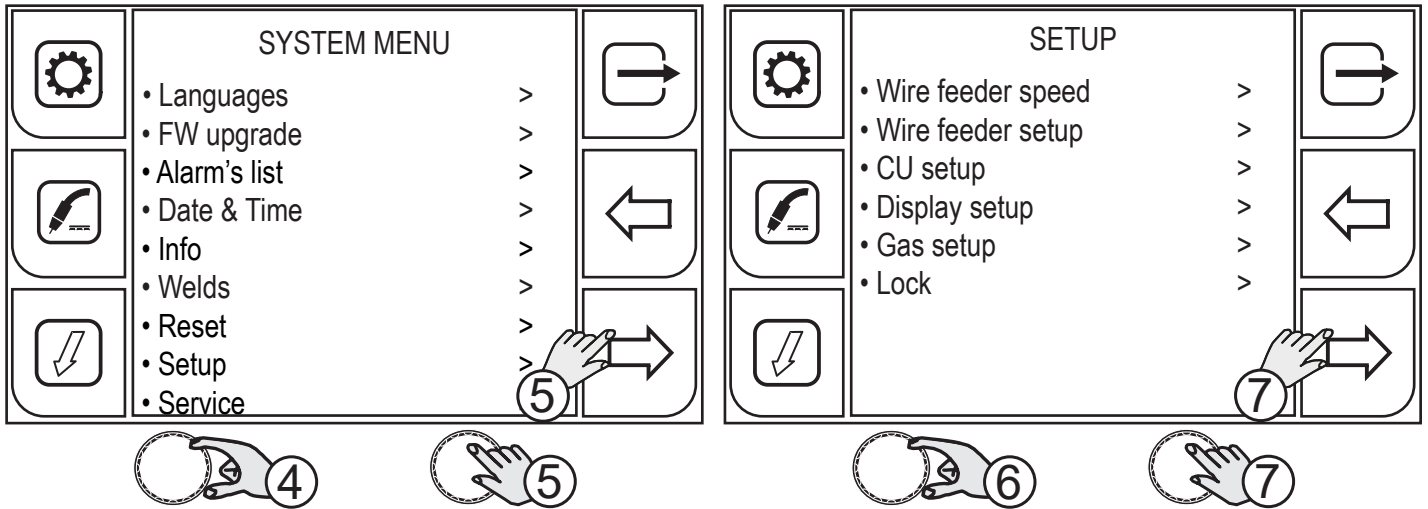

4. Turn the encoder to select the desired setting. Select the following path: Setup>
5. Press the (ENCODER) key or the (NEXT) key to confirm.
6. Turn the encoder to select the desired setting. Select the following path: Gas setup>
7. Press the (ENCODER) key or the (NEXT) key to confirm.

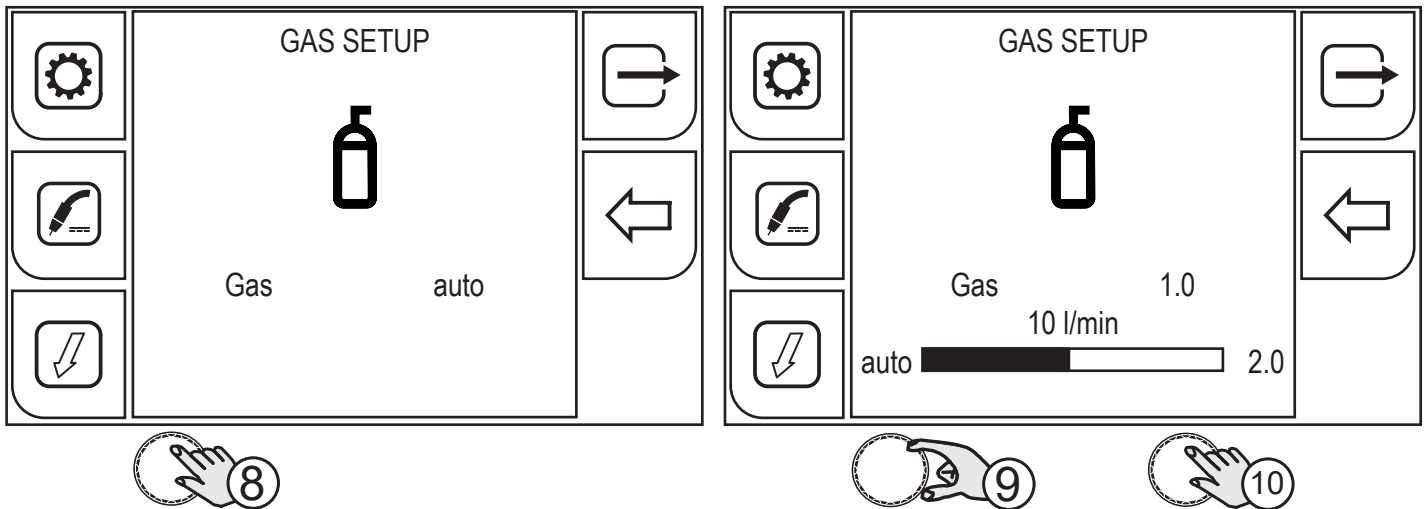

8. Press the (ENCODER) key to apply the parameter change.
9. Turn the encoder to set the desired value. The gas flow value (litre/minute) displayed on the screen must match the value detected in the gas flow reader.
10. Press the (ENCODER) key or the (NEXT) key to confirm.

Press the  key to exit the screen.

5.3 TORCH LOADING



WARNING!

Make sure the torch in use is correctly sized in relation to the welding current required and for the available and selected cooling type. This prevents the risk of burns to which the operator is potentially exposed, potential faults, and irreversible damage to the torch and the system.

If a torch is installed or replaced while the unit is running, the circuit of the newly installed must be filled with coolant to avoid the risk of damage to the torch in the case of high voltage arc strikes without any liquid in the circuit.

When the generator is switched on, the presence of coolant in the cooling circuit will be automatically checked and the cooling unit will be switched on for 30 seconds.

If the coolant circuit is full, the power generator restores the most recent stable welding setup.

If the coolant circuit is not full, all functions are inhibited and there will be no output power.

The following alarm message will be displayed: E50 - COOLING UNIT ALARM

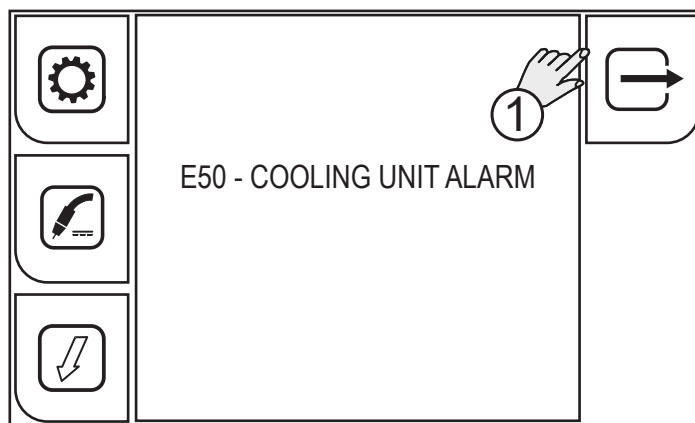

1. Press the (EXIT) key to repeat the torch filling procedure until the alarm is no longer displayed.

5.4 SETTING UP THE WELDING PARAMETERS

The  (PROGRAM) keys allows the user to access a screen sequence required to select the welding program.

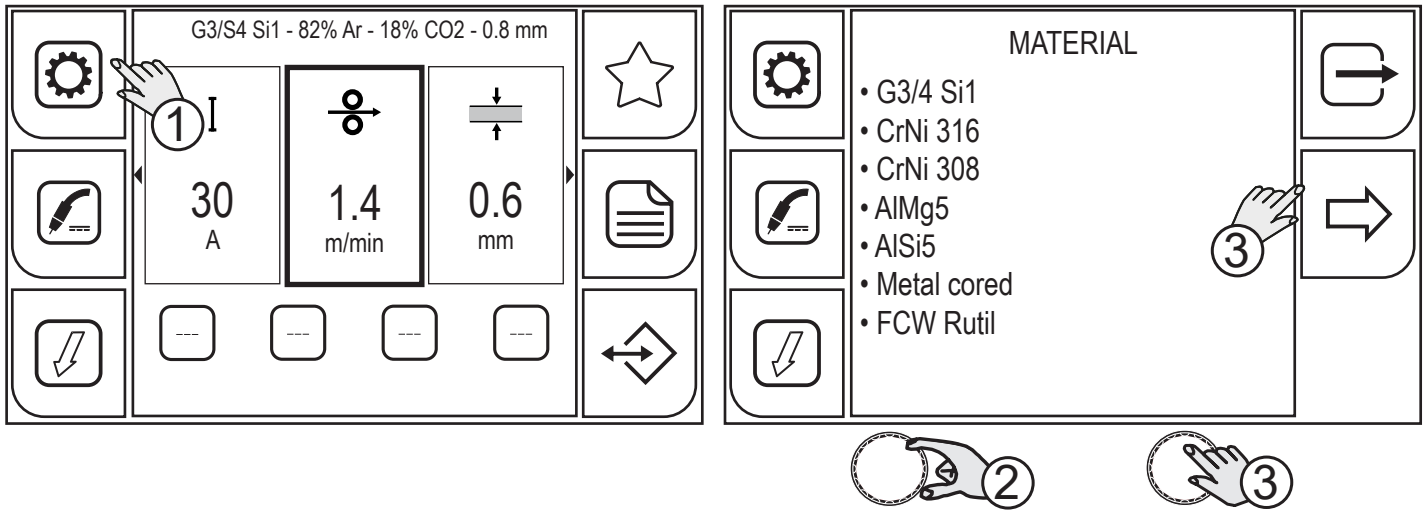

1. Press the (PROGRAM) key. Program all the sequentially displayed screens.

MATERIAL: allows the material of the feed wire used for welding to be selected.

○ (G3/4 Si1, CrNi 316, CrNi 309, CrNi 308, AlMg5, AISi5, AlMg4.5MnZr, Metal Cored, FCW Rutil, FCW Basic, CuSi3, CuSn, Duplex, Super Duplex, NiCrMo3)

2. Turn the encoder to select the desired setting.

3. Press the (ENCODER) key or the (NEXT) key.

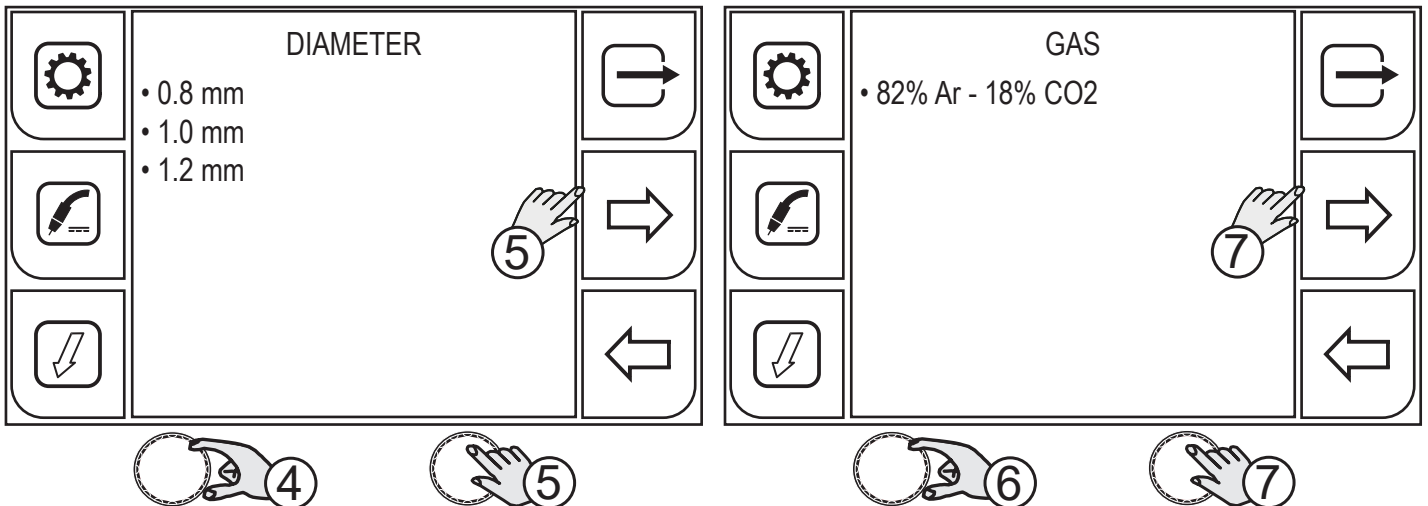

DIAMETER: allows the diameter of the feed wire used for welding to be selected. The wire diameters are available according to the selected material.

4. Turn the encoder to select the desired setting.

5. Press the (ENCODER) key or the (NEXT) key.

GAS: allows the type of welding gas to be selected. The gas mixtures are available according to the selected material.

6. Turn the encoder to select the desired setting.

7. Press the (ENCODER) key or the (NEXT) key.

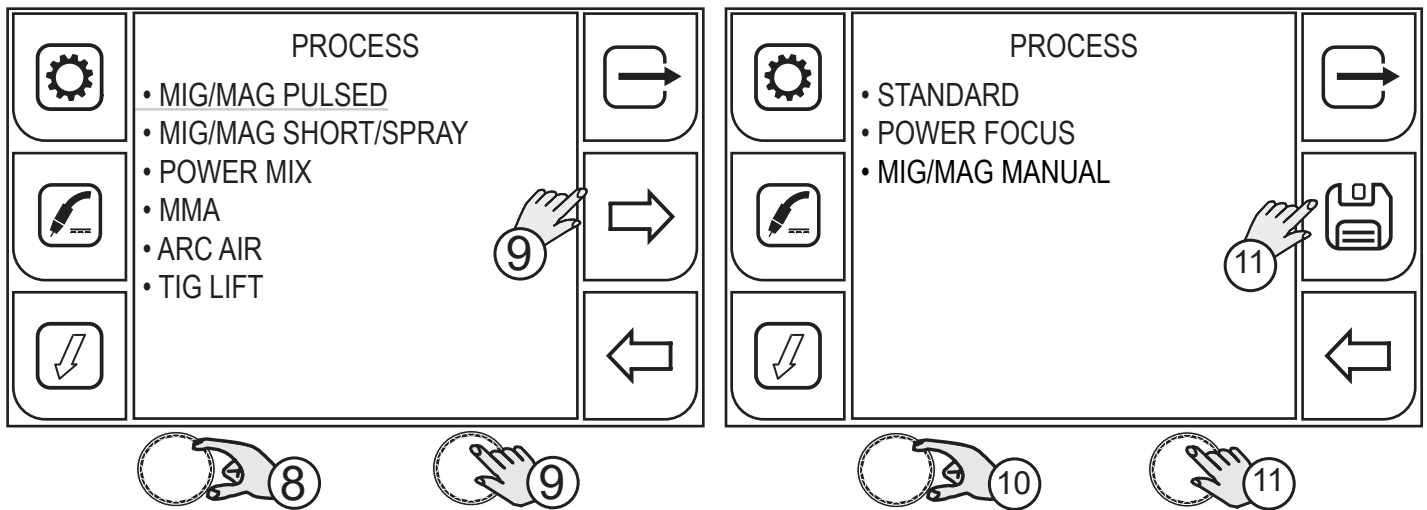



PROCESS (1 LEVEL): allows only the welding processes compatible with the previously carried out settings to be selected.

8. Turn the encoder to select the desired setting.
9. Press the (ENCODER) key or the (NEXT) key.

PROCESS (2 LEVEL): Allows a specific mode of a previously selected welding process to be selected.

10. Turn the encoder to select the desired setting.
11. Press the (ENCODER) key or the (SAVE) key to confirm the program.

Press the  (PREC) key to return to the previous screen.

To return to the main screen without saving the changes, press the  (EXIT) key.

5.4.1 MIG/MAG WELDING PROCESSES

MANUAL MIG/MAG WELDING

Welding is of the Short/Spray type.

- short arc: the drop is detached after a low amperage short-circuit.
- globular: this is the phase occurring between the short arc and the spray arc.
- spray arc: the material is deposited when high amperages occur without short-circuits.

The main welding parameters, the wire speed, the voltage and inductance values are adjusted by the operator. The optimal work point must be identified for the required welding type.



SYNERGIC MIG/MAG WELDING

Welding is of the Short/Spray type.

- short arc: the drop is detached after a low amperage short-circuit.
- globular: this is the phase occurring between the short arc and the spray arc.
- spray arc: the material is deposited with high amperages without short-circuits occurring.

The welding related data (material, wire diameter, gas type) must be set up, as well as a single welding parameter amongst wire speed, amperage, material thickness and voltage.

The generator automatically adjusts the other secondary parameters that affect the welding quality.



PULSED MIG/MAG WELDING

The pulsed process is a welding process where material deposition is controlled by carrying out an accurate regulation of the current pulse.

The welding related data (material, wire diameter, gas type) must be set up, as well as a single welding parameter amongst wire speed, amperage, material thickness and voltage.

The generator automatically adjusts the other secondary parameters affecting the welding quality.



SYNERGIC MIG/MAG WELDING (POWER MIX)

The process combines the short/spray process and the pulsed process and aims at reducing the average heat input in order to be able to perform vertical up or corner welds in all positions with an excellent aesthetic quality of joints and no defects.

The benefits in welding are:

- Quality of vertical up and corner welds
- Simple and fast set-up thanks to the synergic programs
- Good speed of execution
- Low heat input and less deformation
- High aesthetic quality of joints
- Low risk of typical defects especially in critical positions such as vertical up welds
- Applicable on different types of steel and thicknesses

5.4.2 MIG/MAG WELDING FUNCTIONS



DOUBLE PULSE SYNERGIC MIG/MAG WELDING

The DOUBLE PULSE is a function available in the synergic MIG/MAG and in the pulsed MIG/MAG welding process. This function allows the two wire feed speeds to be controlled.

The welding related data (material, wire diameter, gas type) must be set up, as well as a single welding parameter amongst wire speed, amperage, material thickness and voltage.

The generator automatically adjusts the other secondary parameters that affect the welding quality.



HC (HIGH CONTROL) SYNERGIC MIG/MAG WELDING

The HC ((High Control) function is provided to quickly control the arc in order to optimise the drop detachment with a greatly reduced energy.

The welding benefits are:

- Increased arc stability
- Very reactive arc to the torch movement
- Reduced energy transmitted to the welded workpiece
- Very linear transfer and optimal edge wettability
- Very fast operation
- Spatters and micro projections almost entirely absent.



PF (POWER FOCUS) SYNERGIC MIG/MAG WELDING

The difference between a standard MIG MAG and Power Focus is its concentration and pressure. The POWER FOCUS arc concentration allows the welder to focus the high temperature of the arc in the central section of the deposition, thus avoiding to overheat the sides of the welding. The thermally changed area with the Power Focus arc is less widespread.

The welding benefits are:

- higher penetration and lower risk of sticking
- increased welding speed
- higher arc stability even with long stick-outs
- lower costs of joint preparation
- reduced volumes of bevels to be filled



PR (POWER ROOT) SYNERGIC MIG/MAG WELDING

Power Root is an optimised short arc transfer with the feature of having a cold drop transfer. Power Root allows to achieve a very high quality in root passes.

The welding benefits are:

- optimal first pass
- quality of descending vertical welding
- excellent operability
- cold transfer of welding drop
- perfectly jointed thin metal sheets
- ideal for welding joints with large gaps

5.5 SETTING UP THE MIG/MAG TORCH TRIGGER MODE

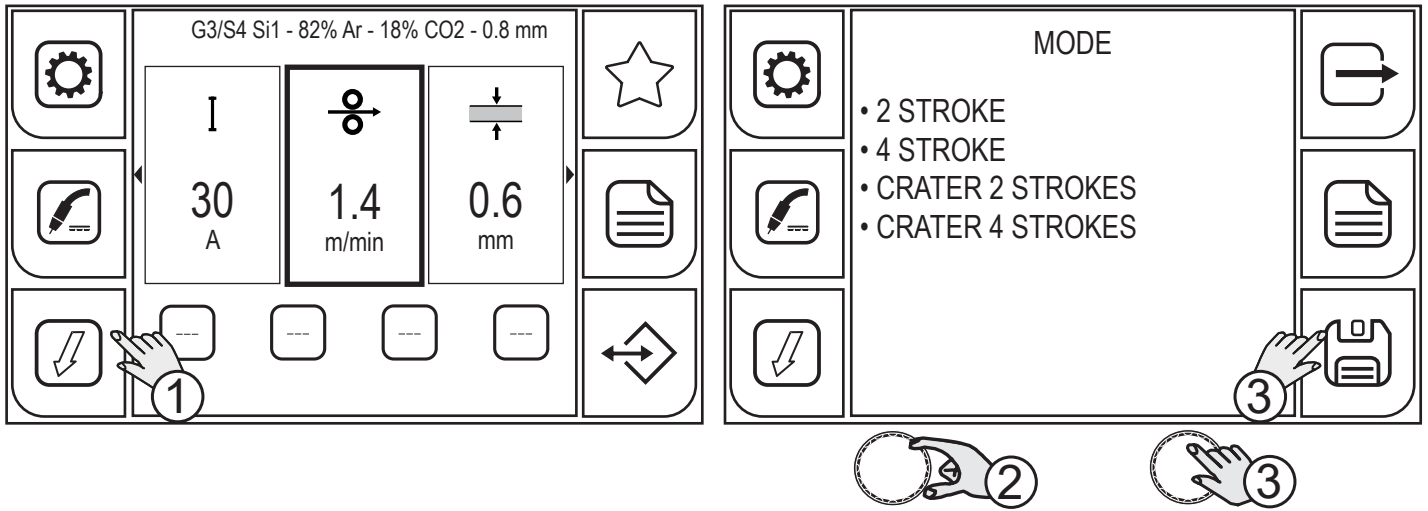

1. Press the (MODE) key.

From within the menu screen, the torch trigger mode can be selected.

 (2 STROKES) -  (4 STROKES) -  (CRATER 2 STROKES) -  (CRATER 4 STROKES)

2. Turn the encoder to select the desired setting.

3. Press the (ENCODER) key or the (SAVE) key to only set up the torch trigger mode, otherwise carry out the procedure shown in paragraph (4).

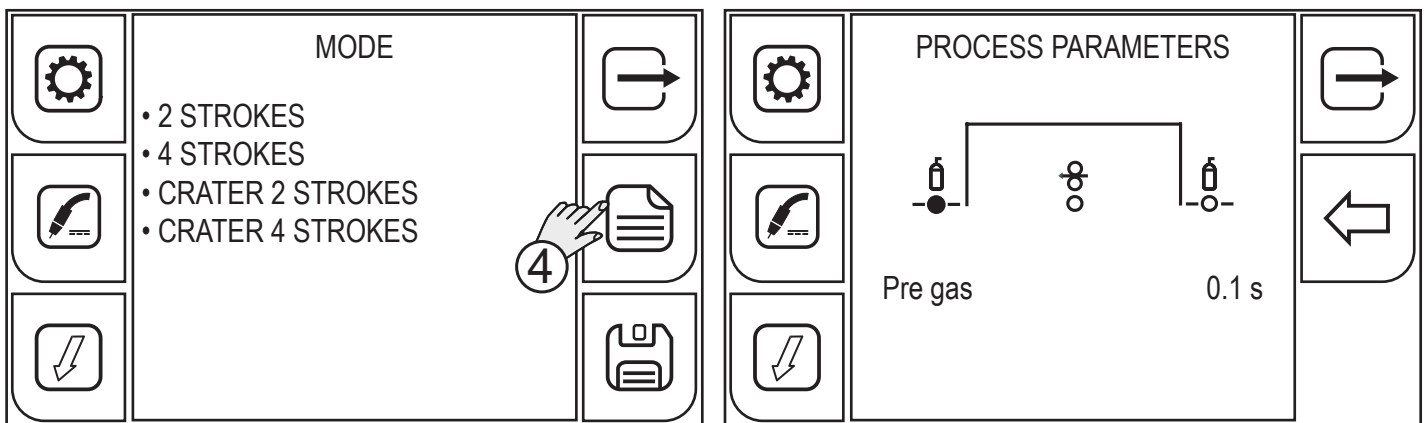

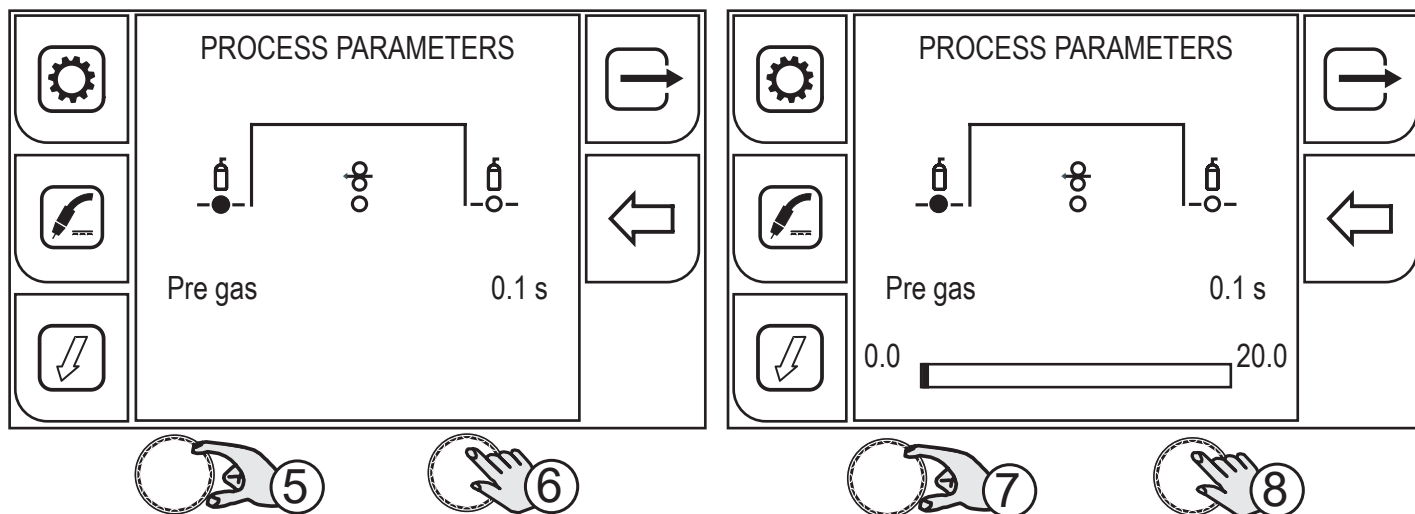

4. Press the (MENU) key.

According to the torch trigger mode selected, different process parameters to be set are available.

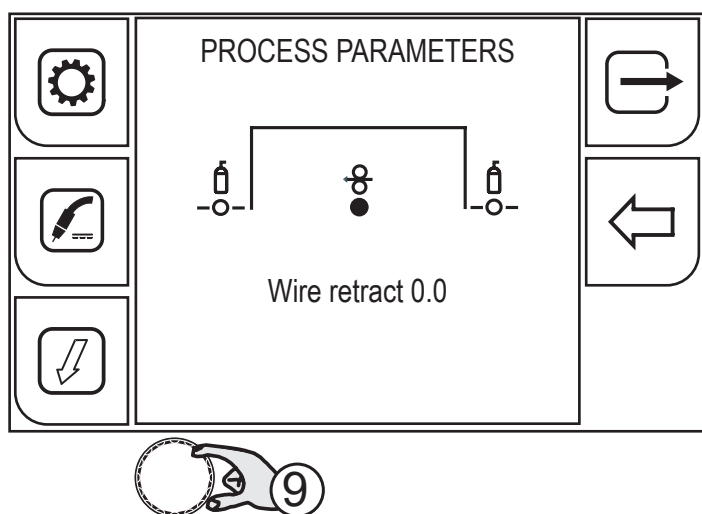

5. Turn the encoder to select the parameter to be changed.
6. Press the (ENCODER) key to confirm.
7. Turn the encoder to set the desired value.
8. Press the (ENCODER) key to confirm.



9. Turn the encoder again to select other parameters.
To return to the main screen, press the  (EXIT) key.

5.5.1 PROCESS PARAMETERS WITH TORCH TRIGGER IN 2 STROKE AND 4 STROKE MODE

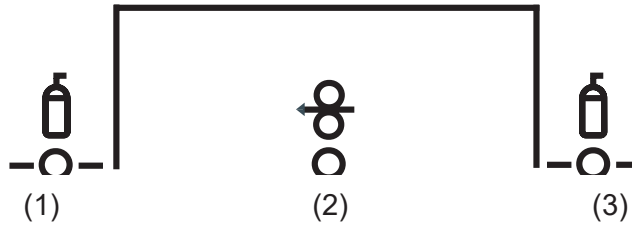

1. PRE GAS

Time of gas delivery before the arc strike.

NOTE: if too long, it will slow down the welding procedure. Other than in the presence of special requirements the value should generally be kept at 0.0 s or anyway very low.

Available range: minimum (0.0 s) - default (0.1 s) - maximum (20.0 s)

2. WIRE RETRACT

The value is associated with the amount of wire to be retracted at the end of the welding operation.

Available range: minimum (0.0 s) - default (0.0 s) - maximum (10.0 s)

3. POST GAS

Time of post gas delivery when the welding arc is extinguished.

Available range: minimum (0.0 s) - default (2.0 s) - maximum (20.0 s)

5.5.2 PROCESS PARAMETERS WITH TORCH TRIGGER IN CRATER 2 STROKE MODE

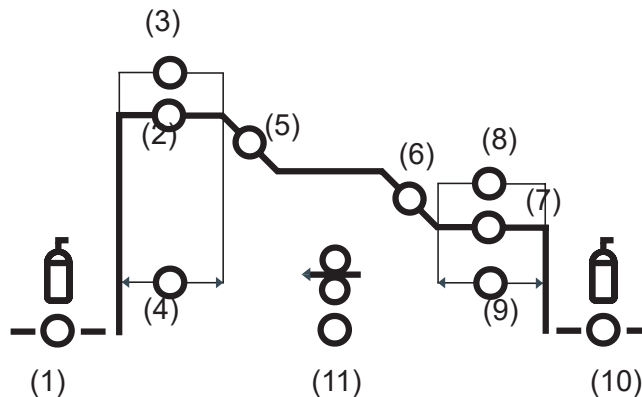

1. PRE GAS

Time of gas delivery before the arc strike.

NOTE: if too long, it will slow down the welding procedure. Other than in the presence of special requirements the value should generally be kept at 0.0 s or anyway very low.

Available range: minimum (0.0 s) - default (0.1 s) - maximum (20.0 s)

2. **STARTING CURRENT**

The parameter adjusts the 1st level wire feed rate as a percentage of the wire feed rate set for welding (2nd level).

Available range: minimum (10 %) - default (130 %) - maximum (200 %)

3. **INITIAL ARC CORRECTION**

This parameter corrects the synergic voltage value relative to the synergic point of the synergic and pulsed MIG/MAG processes, while it manages correction of the voltage of the high value in the MIG/MAG double pulsed process.

Available range: minimum (-10) - default (0.0) - maximum (10)

4. **INITIAL CURRENT TIME**

This parameter specifies for how long the initial current is maintained.

Available range: minimum (0.0 s) - default (0.5 s) - maximum (10.0 s)

5. **SLOPE1**

This parameter controls the slope time connecting the HOT START level and the welding level.

Available range: minimum (0.1 s) - default (0.5 s) - maximum (10.0 s)

6. **SLOPE2**

This parameter controls the slope time connecting the welding level and the crater filler level.

Available range: minimum (0.0 s) - default (0.5 s) - maximum (10.0 s)

7. **FINAL CURRENT**

This parameter adjusts the crater filling wire feed rate as a percentage of the wire feed rate set for welding (2nd level).

Available range: minimum (10 %) - default (80 %) - maximum (200 %)

8. **FINAL ARC CORRECTION**

This parameter corrects the synergic voltage value relative to the synergic point of the synergic and pulsed MIG/MAG processes, while it manages correction of the voltage of the high value in the MIG/MAG double pulsed process.

Available range: minimum (-10.0) - default (0) - maximum (10.0)

9. **FINAL CURRENT TIME**

This parameter specifies for how long the final current is maintained.

Available range: minimum (0.0 s) - default (0.5 s) - maximum (10.0 s)

10. **POST GAS**

Time of post gas delivery when the welding arc is extinguished.

Available range: minimum (0.0 s) - default (2.0 s) - maximum (20.0 s)

11. **WIRE WITHDRAWAL**

The value is associated with the amount of wire to be withdrawn at the end of the welding operation.

Available range: minimum (0.0) - default (0.0) - maximum (10.0)

5.5.3 PROCESS PARAMETERS WITH TORCH TRIGGER IN CRATER 4 STROKE MODE

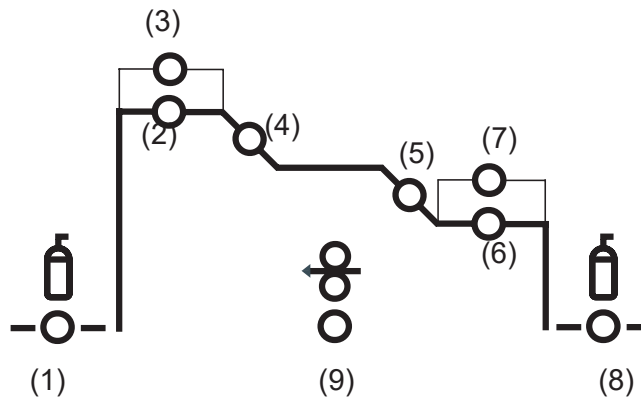

1. PRE GAS

Time of gas delivery before the arc strike.

NOTE: if too long, it will slow down the welding procedure. Other than in the presence of special requirements the value should generally be kept at 0.0 s or anyway very low.

Available range: minimum (0.0 s) - default (0.1 s) - maximum (20.0 s)

2. STARTING CURRENT

The parameter adjusts the 1st level wire feed rate as a percentage of the wire feed rate set for welding (2nd level).

Available range: minimum (10 %) - default (130 %) - maximum (200 %)

3. INITIAL ARC CORRECTION

This parameter corrects the synergic voltage value relative to the synergic point of the synergic and pulsed MIG/MAG processes, while it manages correction of the voltage of the high value in the MIG/MAG double pulsed process.

Available range: minimum (-10) - default (0.0) - maximum (10)

4. SLOPE1

The parameter controls the slope time connecting the HOT START level and the welding level.

Adjustment range: minimum (0.1 s) - default (0.5 s) - maximum (10.0 s)

5. SLOPE2

The parameter controls the slope time connecting the welding level and the crater filler level.

Adjustment range: minimum (0.0 s) - default (0.5 s) - maximum (10.0 s)

6. FINAL CURRENT

This parameter adjusts the crater filling wire feed rate as a percentage of the wire feed rate set for welding (2nd level).

Adjustment range: minimum (10 %) - default (80 %) - maximum (200 %)

7. FINAL ARC CORRECTION

This parameter corrects the synergic voltage value relative to the synergic point of the synergic and pulsed MIG/MAG processes, while it manages correction of the voltage of the high value in the MIG/MAG double pulsed process.

Available range: minimum (-10.0) - default (0) - maximum (10.0)

8. POST GAS

Time of post gas delivery when the welding arc is extinguished.

Available range: minimum (0.0 s) - default (2.0 s) - maximum (20.0 s)

9. WIRE WITHDRAWAL

The value is associated with the amount of wire to be withdrawn at the end of the welding operation.

Available range: minimum (0.0) - default (0.0) - maximum (10.0)

5.5.4 MIG/MAG 2S OPERATION

- ↓ : press the torch trigger
- ↑ : release the torch trigger
- ↓↑ : press and release the torch trigger

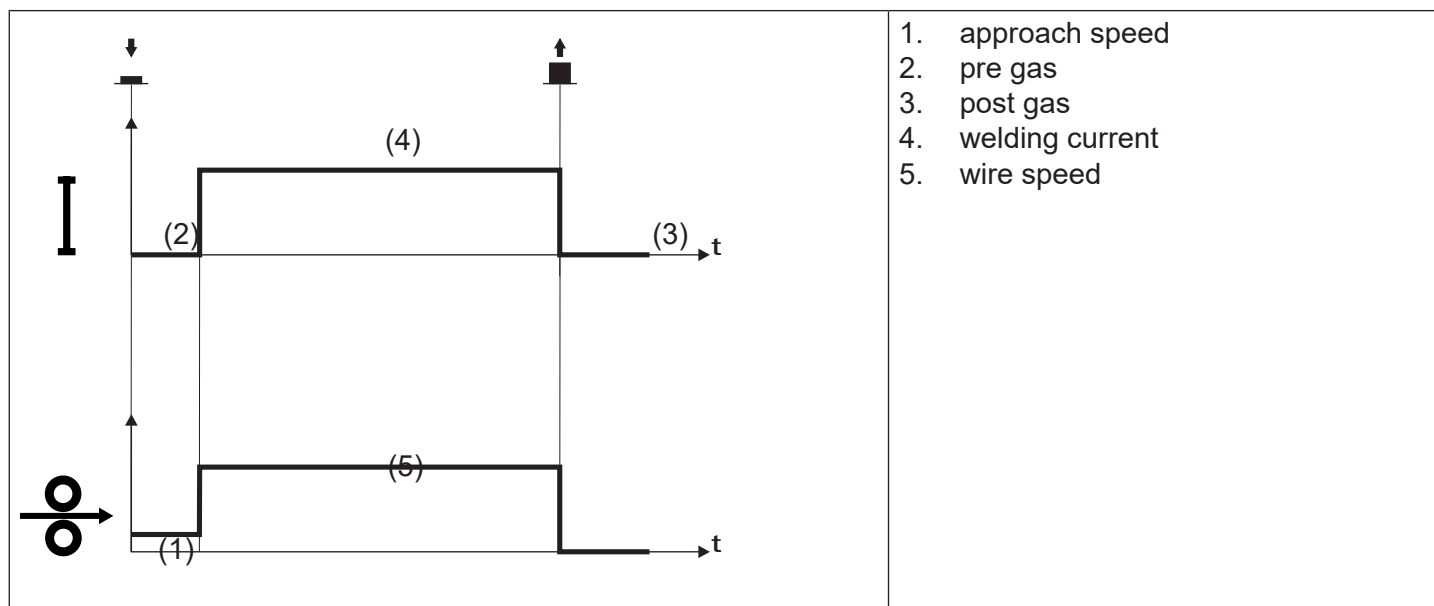

- Bring the torch up to the workpiece to be welded.
- Press (1S) and keep the torch trigger pressed.
 - The wire advances at the approach speed until making contact with the workpiece. If the arc does not strike after 10 cm wire protrusion, wire feeding is locked and the welding unit outputs are de-energized.
 - The arc strikes and the wire feeder accelerates to the set feed rate value.
- Release (2S) the trigger to complete the welding operation.
 - Gas flow continues for the time set in the post gas parameter (adjustable time).

5.5.5 MIG/MAG 2S SPOT OPERATION

- ↓ : press the torch trigger
- ↑ : release the torch trigger
- ↕ : press and release the torch trigger

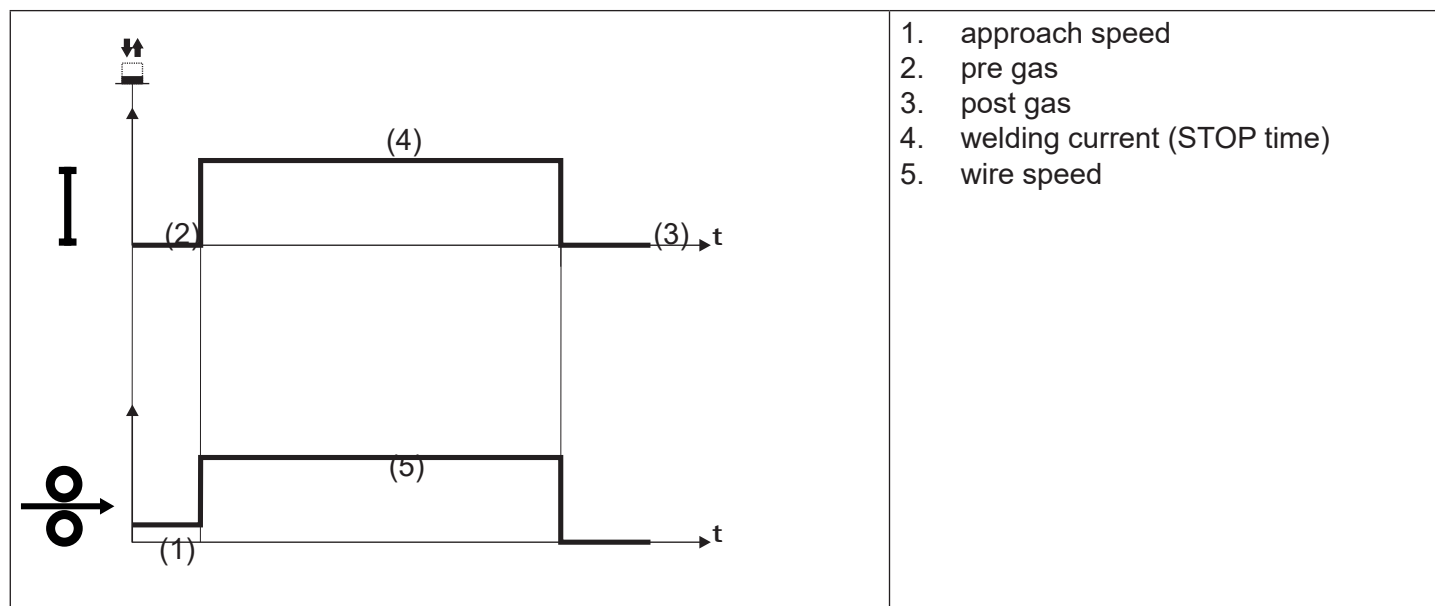

1. approach speed
2. pre gas
3. post gas
4. welding current (STOP time)
5. wire speed

- Bring the torch up to the workpiece to be welded.
- Press (1S) and keep the torch trigger pressed.
 - The wire advances at the approach speed until making contact with the work. If the arc does not strike after 10 cm wire protrusion, wire feeding is locked and the welding unit outputs are de-energized.
 - The arc strikes and the wire feeder accelerates to the set feed rate value.
 - The welding procedure continues, at the preset current, for the time set with the spot time parameter.
 - When the SPOT time has expired, the welding operation will be automatically stopped.
 - Gas flow continues for the time set in the post gas parameter (adjustable time).

5.5.6 MIG/MAG 4S OPERATION

- ↓ : press the torch trigger
- ↑ : release the torch trigger
- ↕ : press and release the torch trigger

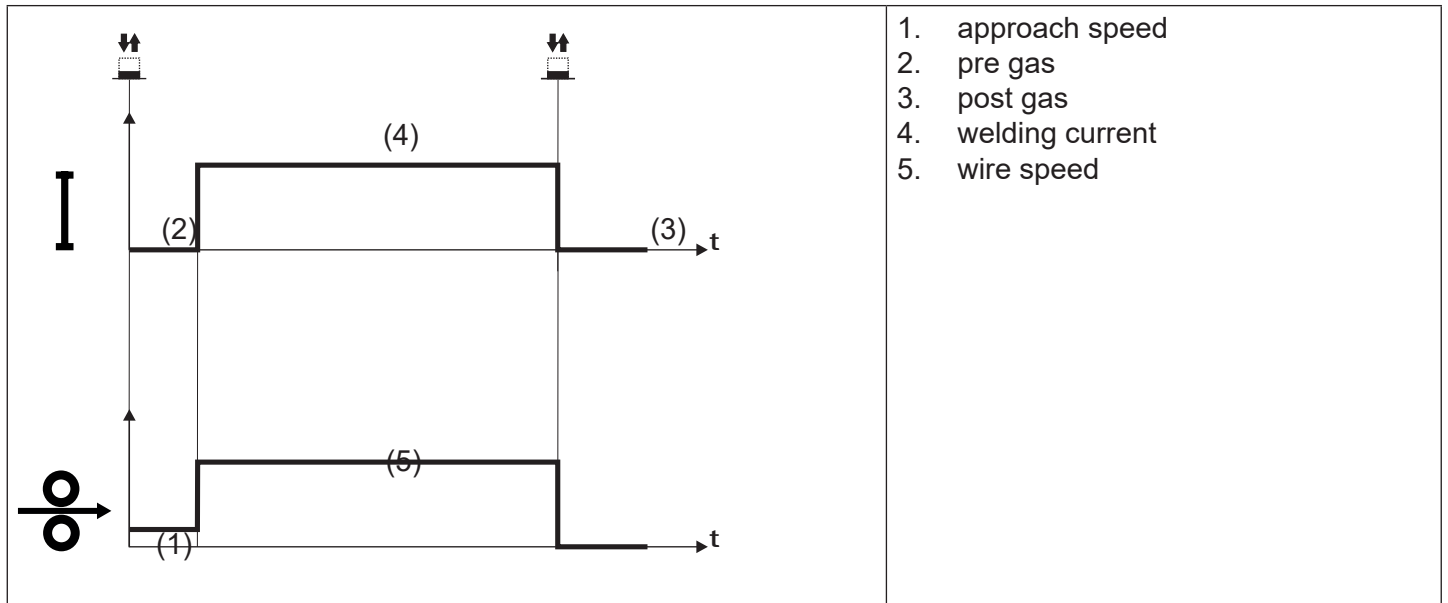

- Bring the torch up to the workpiece to be welded.
- Press (1S) and release (2S) the torch trigger.
 - The wire advances at the approach speed until making contact with the work. If the arc does not strike after 10 cm wire protrusion, wire feeding is locked and the welding unit outputs are de-energized.
 - The arc strikes and the wire feeder accelerates to the set feed rate value.
- Press (3S) the trigger to start the weld completion procedure.
 - Gas flow continues until the torch trigger is released.
- Release (4S) torch trigger to start the post gas procedure (adjustable time).

5.5.7 MIG/MAG 4S B-LEVEL OPERATION

- ↓ : press the torch trigger
- ↑ : release the torch trigger
- ↑↓ : press and release the torch trigger

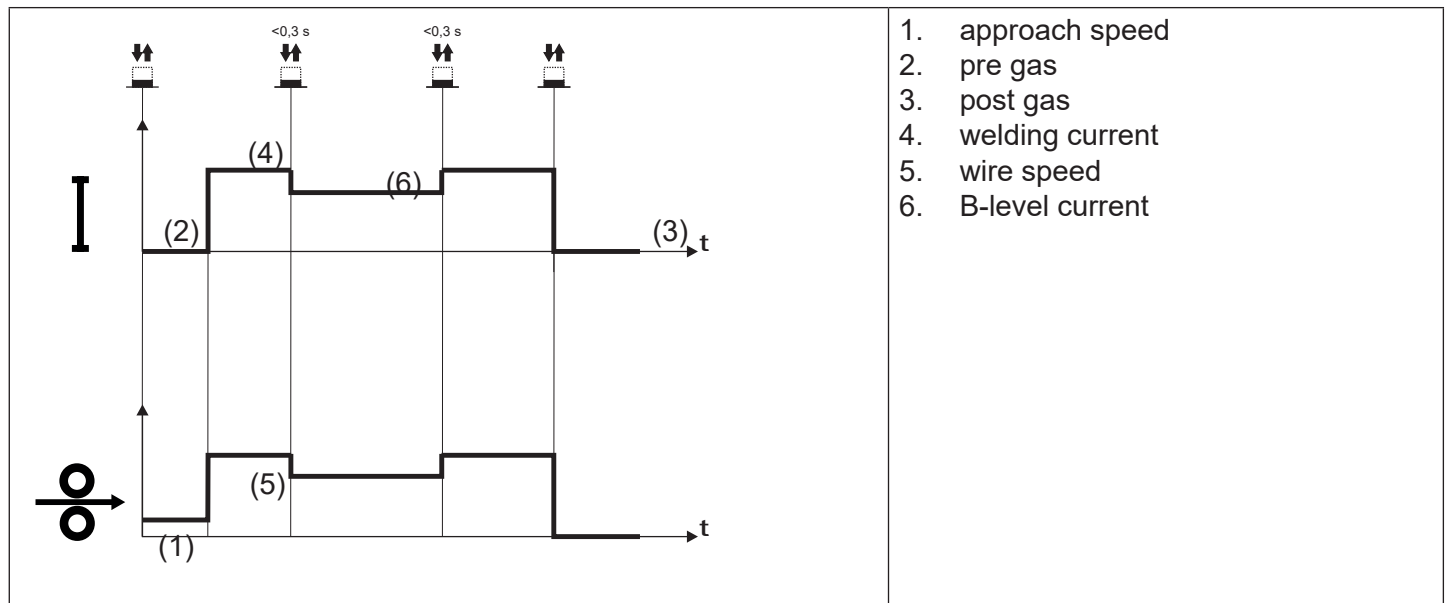

1. approach speed
2. pre gas
3. post gas
4. welding current
5. wire speed
6. B-level current

- Bring the torch up to the workpiece to be welded.
- Press (1S) and release (2S) the torch trigger.
 - The wire advances at the approach speed until making contact with the work. If the arc does not strike after 10 cm wire protrusion, wire feeding is locked and the welding unit outputs are de-energized.
 - The arc strikes and the wire feeder accelerates to the set feed rate value.
 - During normal speed welding, press and immediately release the torch trigger to switch to the second welding current.
 - The trigger must not be pressed for more than 0.3 seconds; otherwise, the weld completion stage will start.
 - When the trigger is pressed and released immediately, the system returns to the welding current.
- Press (3S) trigger and keep it pressed to start the weld completion procedure.
 - Gas flow continues until the torch trigger is released.
- Release (4S) torch trigger to start the post gas procedure (adjustable time).

5.5.8 MMIG/MAG CRATER 2S OPERATION

- ↓ : press the torch trigger
- ↑ : release the torch trigger
- ↑↓ : press and release the torch trigger

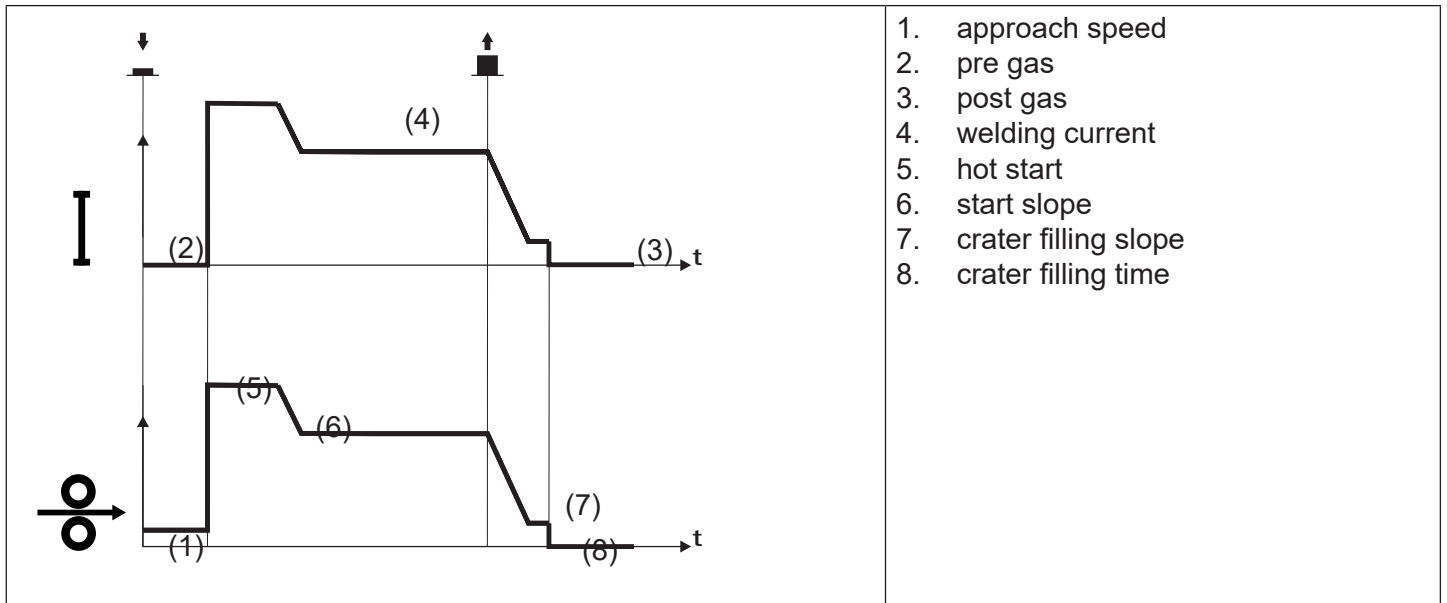

- Bring the torch up to the workpiece to be welded.
- Press (1S) torch trigger.
 - The wire advances at the approach speed until making contact with the work. If the arc does not strike after 10 cm wire protrusion, wire feeding is locked and the welding unit outputs are de-energized.
 - The welding arc strikes and the wire feed rate changes to the first welding level (hot start), which is set as a percentage of the normal welding feed rate.
 - This first level is used to create the weld pool: for example, when welding aluminium a value of 130 % is recommended.
 - The hot start level continues for the start time, which is settable in seconds; then switch to normal welding speed is performed in accordance with the start slope, which can be set in seconds.
- Release (2S) the torch trigger to switch to the third welding level (crater filler), which is set as a percentage of the normal welding feed rate.
 - The switch of welding current level in terms of crater filling is performed in accordance with the crater ramp, which can be set in seconds.
 - This third level is used to complete the weld and fill the final crater (crater filler) in the weld pool: for example, when welding aluminium a value of 80 % is recommended.
 - The crater filler level continues for the crater filling time, which is settable in seconds; at the end of this time welding is interrupted and the post gas stage is performed.

5.5.9 MMIG/MAG CRATER 2S OPERATION

- ↓ : press the torch trigger
- ↑ : release the torch trigger
- ↑↓ : press and release the torch trigger

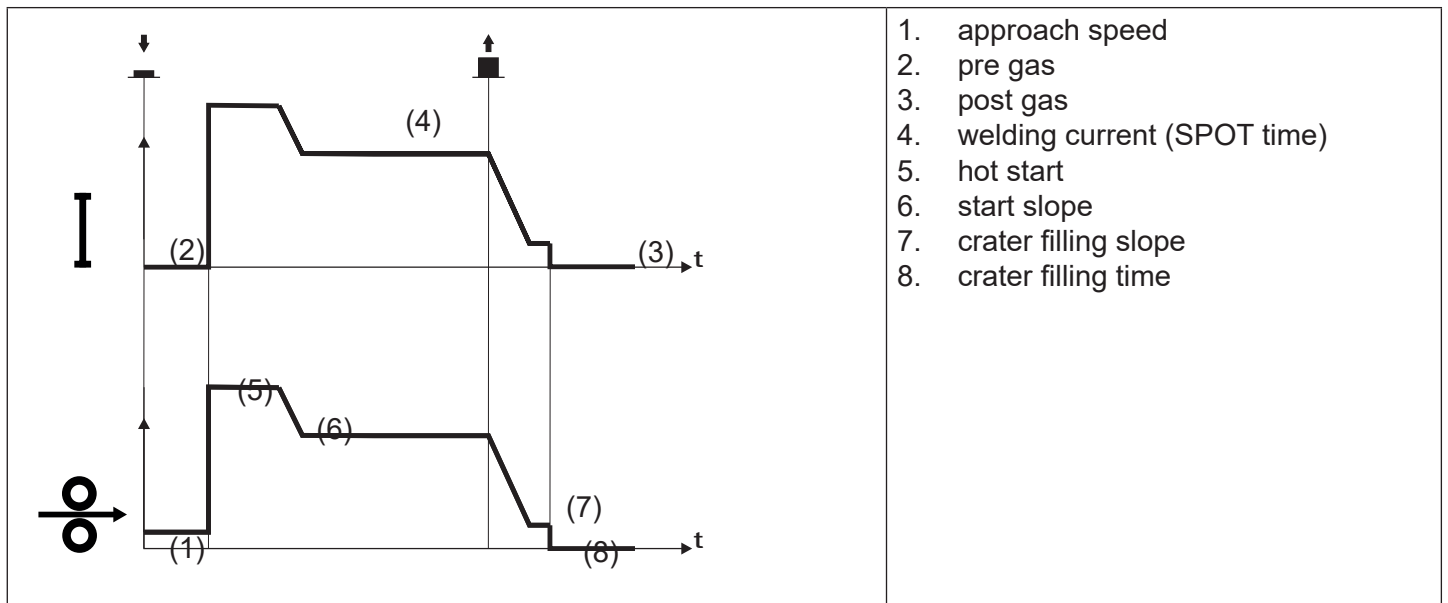

The welding process is the same as the CRATER 2S process, except that the welding procedure continues, at the preset current, for the time set with the spot time parameter.
The weld is closed in the same way as with the CRATER 2S process.

5.5.10 MMIG/MAG CRATER 4S OPERATION

- ↓ : press the torch trigger
- ↑ : release the torch trigger
- ↓↑ : press and release the torch trigger

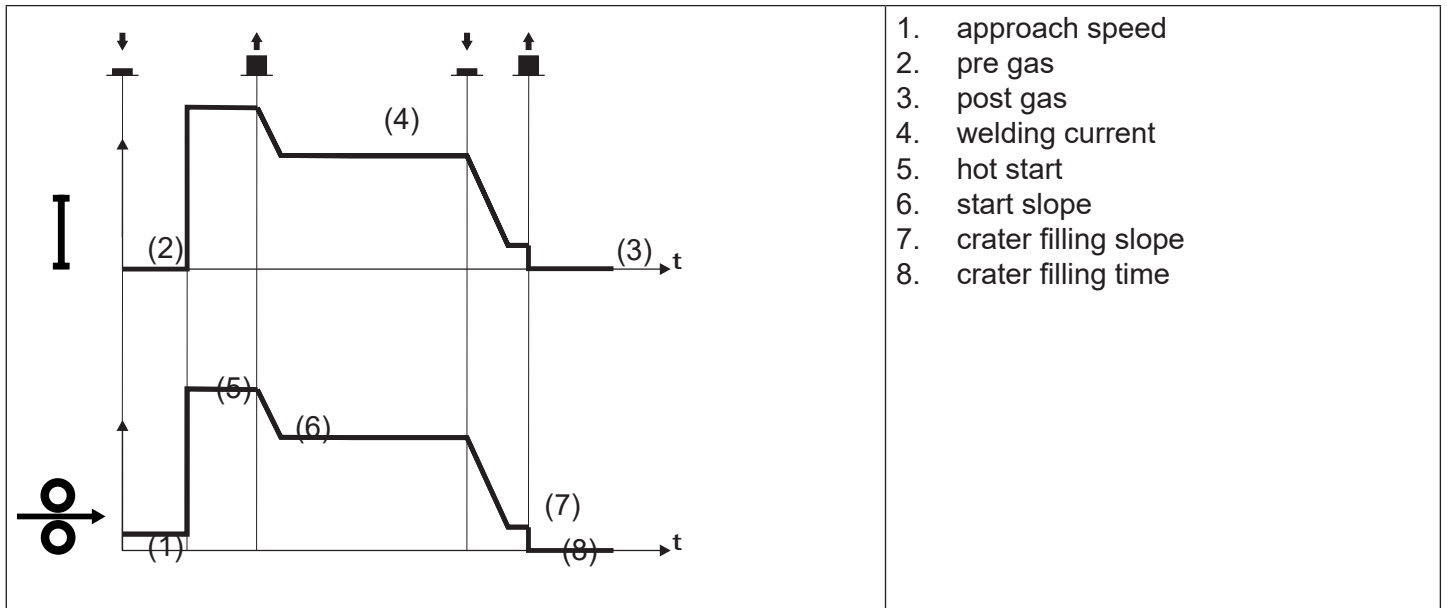

- Bring the torch up to the workpiece to be welded.
- Press (1S) torch trigger.
 - The wire advances at the approach speed until making contact with the work. If the arc does not strike after 10 cm wire protrusion, wire feeding is locked and the welding unit outputs are de-energized.
 - The welding arc strikes and the wire feed rate changes to the first welding level (hot start), which is set as a percentage of the normal welding feed rate.
 - This first level is used to create the weld pool: for example, when welding aluminium a value of 130 % is recommended.
- Release (2S) trigger to switch to normal welding speed; then switch to normal welding speed is performed in accordance with the start slope, which can be set in seconds.
- Press the torch trigger again (3S) to switch to the third welding level (crater filling), which is set as a percentage of the normal welding feed rate.
 - The welding level is changed from the crater filling mode by using the crater slope that can be specified in seconds.
 - This third level is used to complete the weld and fill the final crater (crater filler) in the weld pool: for example, when welding aluminium a value of 80 % is recommended.
- Release the torch trigger a second time (4S) to close the weld and run the post gas procedure.

5.5.11 MIG/MAG CRATER 4S B-LEVEL OPERATION

- ↓ : press the torch trigger
- ↑ : release the torch trigger
- ↑↓ : press and release the torch trigger

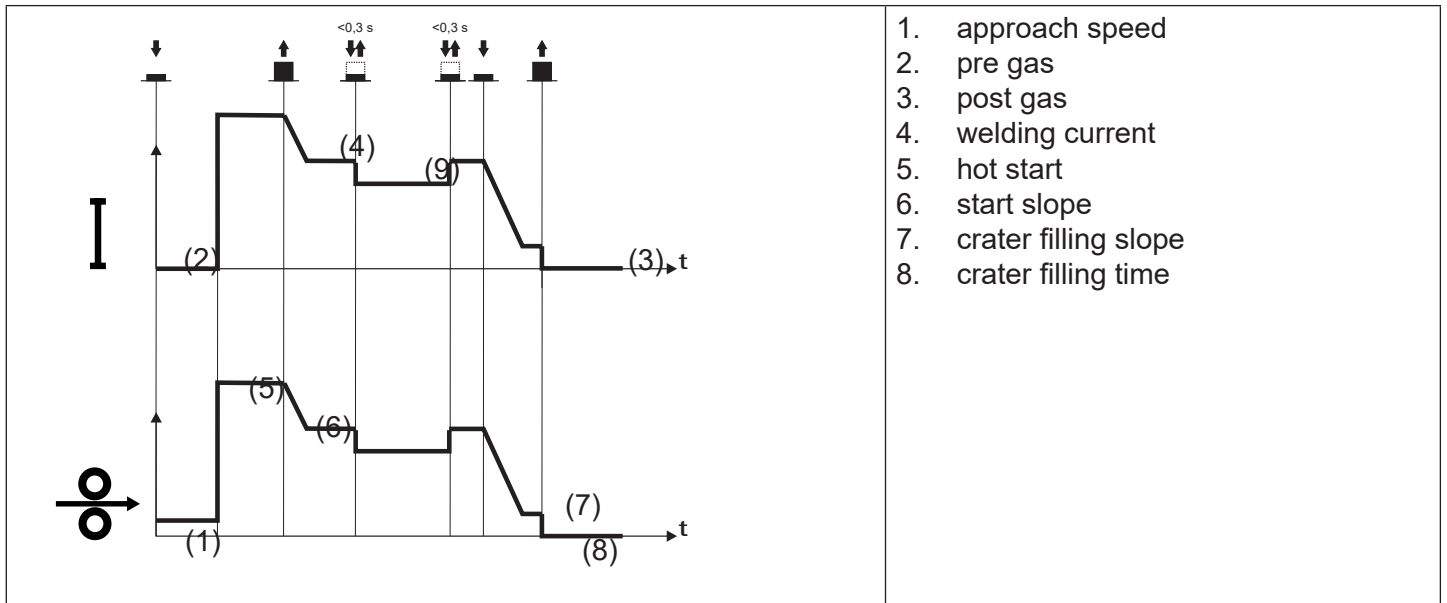

1. approach speed
2. pre gas
3. post gas
4. welding current
5. hot start
6. start slope
7. crater filling slope
8. crater filling time

The welding process is the same as the crater 4S process; however, in this case, during the normal welding speed, if the torch trigger is pressed and released, the second welding current is applied. The trigger must not be pressed for more than 0.3 seconds; otherwise, the weld completion stage will start. When the trigger is pressed and released immediately, the system returns to the welding current. Press (3S) and keep it pressed to start the crater filling procedure. The weld is closed in the same way as with the crater 4S process.

6 PARAMETERS SETTING

The  (PARAMETERS MENU) key allows the user to access the menu used to set the main welding features. This key also features special functions such as the welding circuit calibration and the system menu.

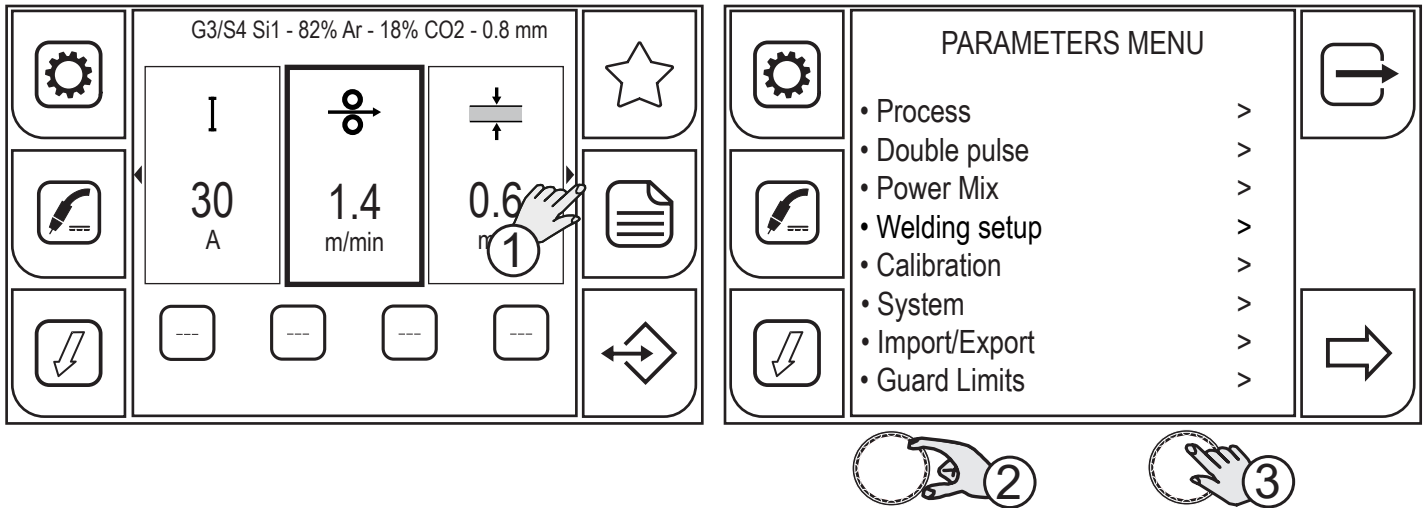

Press the (MENU) key.

1. Turn the encoder to select the desired setting.
2. Press the (ENCODER) key or the (NEXT) key.

Use this method to program all the sequentially displayed screens:

- PROCESS

By using the PROCESS PARAMETERS menu, the values of the parameters associated with the set torch trigger mode can be set.

- DOUBLE PULSE

By using the DOUBLE PULSE PARAMETERS menu, the values of the parameters associated with the DOUBLE PULSE welding process can be set.

- POWER MIX

The POWER MIX PARAMETERS menu can be used to set the parameter values for the POWER MIX welding process.

- WELDING SETUP

By using the WELDING SETUP menu, the available operating modes for the torch trigger can be enabled and the torch trigger parameters can be set.

- CALIBRATION

By using the WELDING CIRCUIT CALIBRATION guided procedure, the resistance and inductance values of the welding circuit are measured.

- SYSTEM

The SYSTEM menu includes several submenus:

- LANGUAGES: to set the language used to display the messages
- FW UPGRADE: to update the equipment software by using the USB memory stick.
- ALARM LIST: allows the user to view a list of the alarms detected.
- DATE & TIME: sets the time zone, the date and the time.

- INFO: provides information related to using the equipment (hours of operation, hours of welding)
- RESET: the reset procedure allows the user to delete the data stored.

- SETUP: sets the wire feed speed when the S8  (WIRE FORWARD) key is pressed.
- SERVICE: to be used by service staff only.

- IMPORT/EXPORT

Some equipment configurations (Jobs, parameters, display setups, language) can be exported or imported onto/from an USB memory stick

6.1 SETTING THE PROCESS PARAMETERS

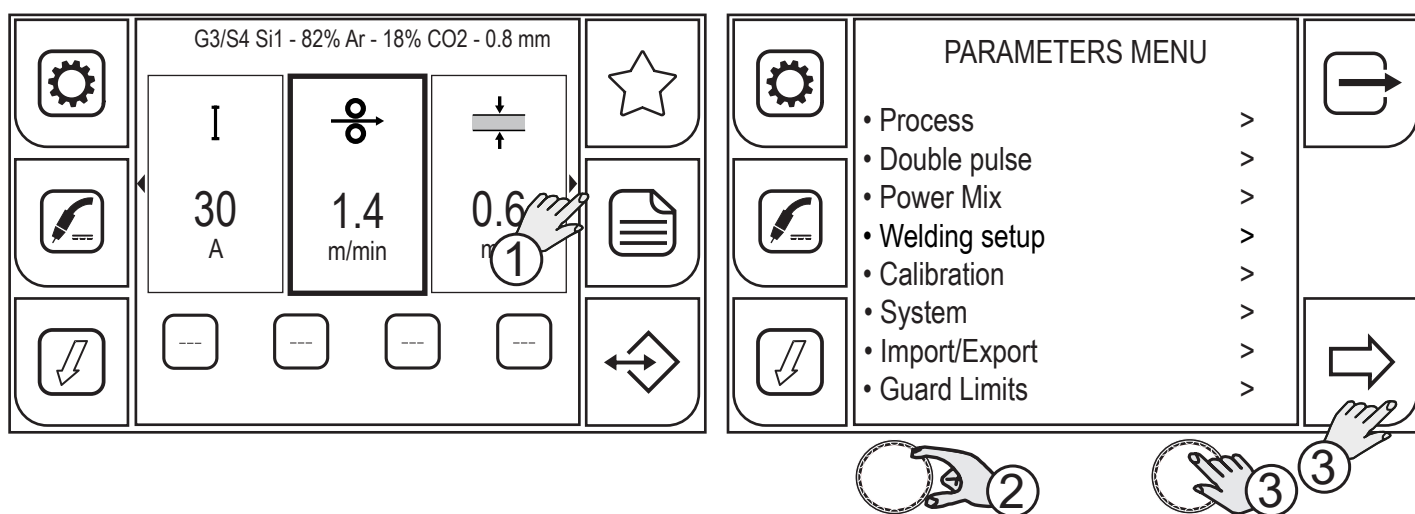

1. Press the (MENU) key.
2. Turn the encoder to select the desired setting. Select the following path: Process>
3. Press the (ENCODER) key or the (NEXT) key to confirm.

According to the torch trigger mode selected, some process parameters to be set are available.

 To view the full list of parameters, please see:

- "5.5.1 PROCESS PARAMETERS WITH TORCH TRIGGER IN 2 STROKE AND 4 STROKE MODE" on page 62
- "5.5.2 PROCESS PARAMETERS WITH TORCH TRIGGER IN CRATER 2 STROKE MODE" on page 62
- "5.5.3 PROCESS PARAMETERS WITH TORCH TRIGGER IN CRATER 4 STROKE MODE" on page 64

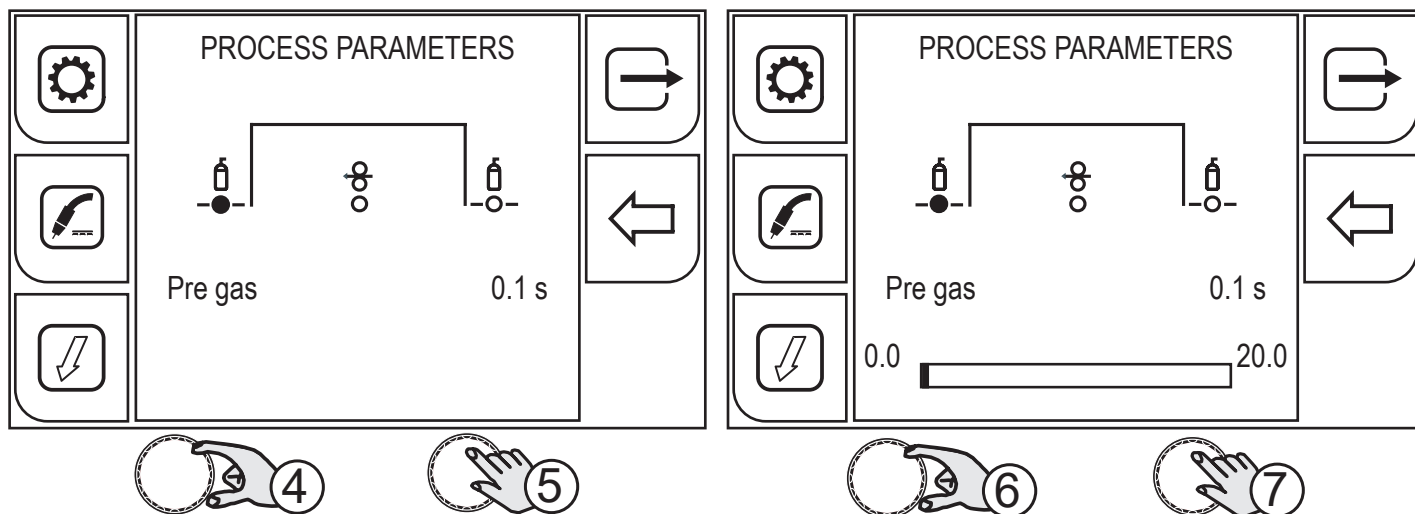

4. Turn the encoder to select the parameter to be changed.
5. Press the (ENCODER) key to confirm your selection.
6. Turn the encoder to set the desired value.
7. Press the (ENCODER) key to confirm.

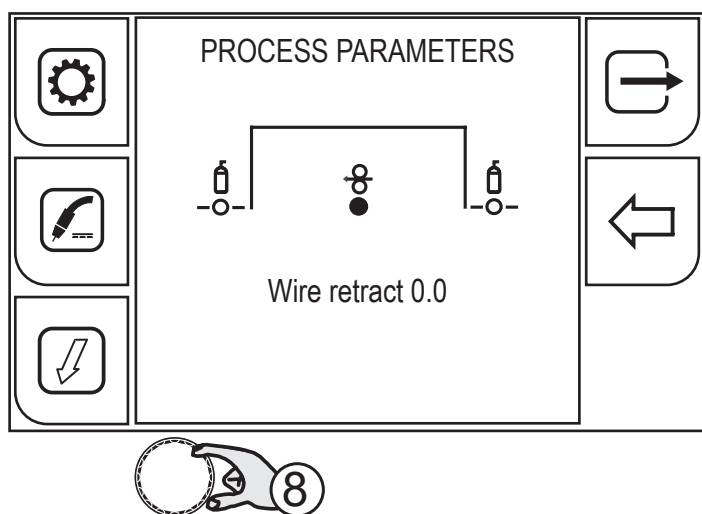

8. Turn the encoder again to select other parameters.
To return to the main screen, press the  (EXIT) key.

6.2 SETTING THE DOUBLE PULSE PARAMETERS

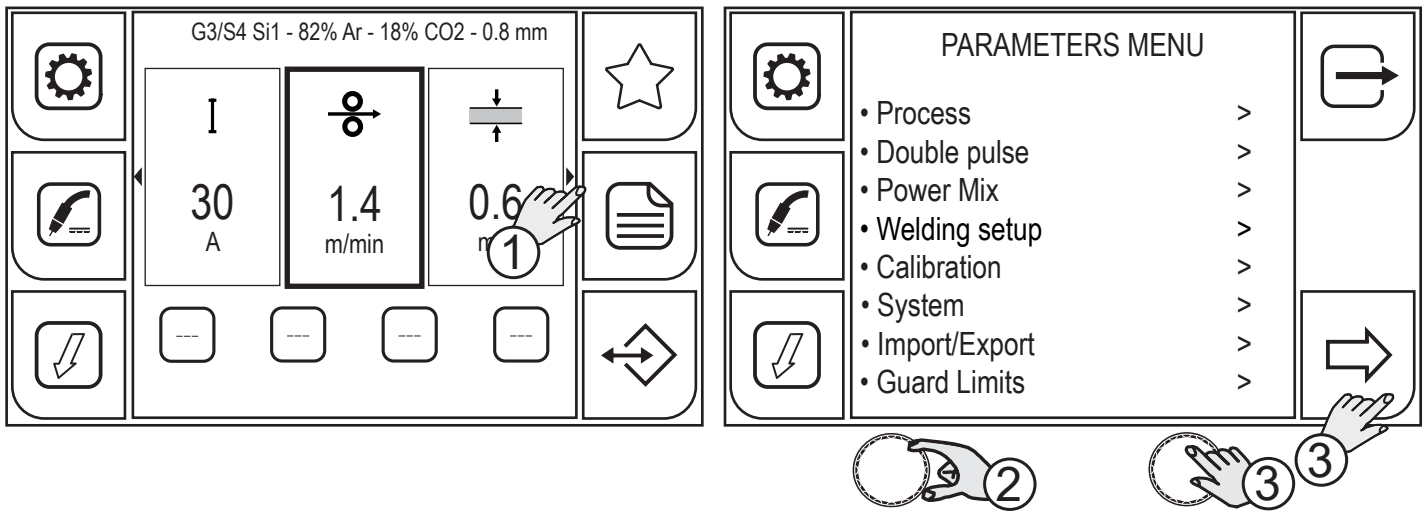

1. Press the (MENU) key.
2. Turn the encoder to select the desired setting. Select the following path: Double pulse>
3. Press the (ENCODER) key or the (NEXT) key to confirm.

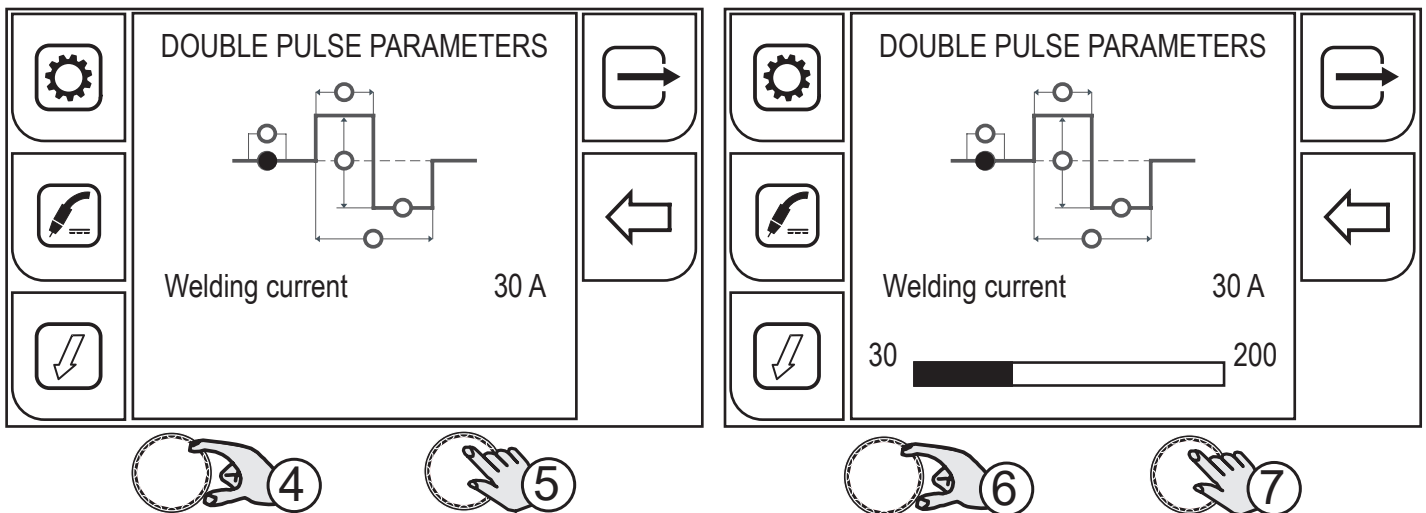

4. Turn the encoder to select the parameter to be changed.
5. Press the (ENCODER) key to confirm.
6. Turn the encoder to set the desired value.
7. Press the (ENCODER) key to confirm.

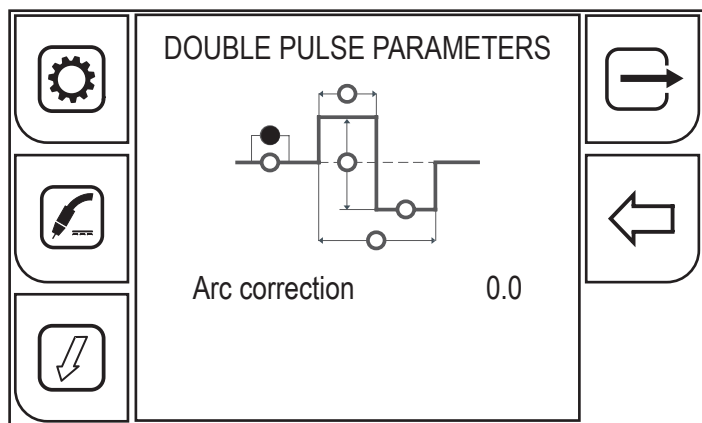

8. Turn the encoder again to select the parameters.

To return to the main screen, press the  (EXIT) key.

6.2.1 DOUBLE PULSE PARAMETERS

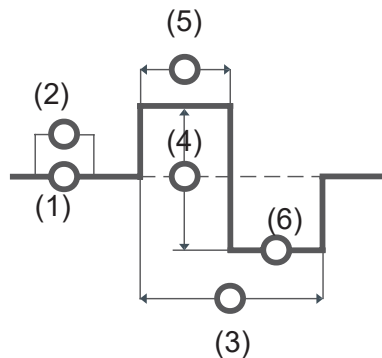

DOUBLE SPEED ACTIVE

This parameter enables/disables the double pulse mode.

Available range: minimum (0.0 s) - default (0.1 s) - maximum (20.0 s)

1. WELDING CURRENT

This parameter regulates the average amperage of the welding arc.

Available range: minimum (30 A) - default (30 A) - maximum (200 A)

2. ARC LENGTH

This parameter corrects the synergic voltage value relative to the synergic point of the synergic and pulsed MIG/MAG processes, while it manages the correction of the voltage of the high value in the MIG/MAG double pulse process.

Available range: minimum (-10) - default (0.0) - maximum (10)

3. DOUBLE SPEED FREQUENCY

This parameter sets the frequency applied to the two wire speeds set with the DOUBLE SPEED AMPL. parameter.

Available range: minimum (0.0 Hz) - default (2.0 Hz) - maximum (5.0 Hz)

4. DOUBLE SPEED AMPL.

The parameter generates the two wire speeds (high and low) used in the double pulse mode, which are alternated with the frequency specified by the DOUBLE SPEED FREQUENCY parameter.

Available range: minimum (0 %) - default (50 %) - maximum (100 %)

5. DOUBLE SPEED DUTY

This parameter adjusts the high speed time.

Available range: minimum (10 %) - default (50 %) - maximum (90 %)

6. DOUBLE SPEED ARC LEN

This parameter corrects the synergic voltage value relative to the synergic point of the synergic and pulse MIG/MAG processes, while it manages correction of the voltage of the low value in the MIG/MAG double pulse process.

Available range: minimum (-10) - default (0.0) - maximum (10)

6.2.2 POWER MIX PARAMETERS

The parameters that can be adjusted from this menu only affect the POWER MIX welding process and do not change the “Arc length correction” and “Dynamics” parameters displayed on the main page, which only refer to the pulsed arc welding process.

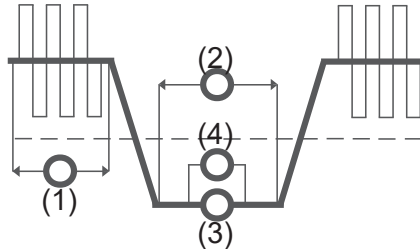

1. PULSED ARC TIME CORRECTION

The parameter corrects the synergic value of the pulsed arc time.

Adjustment range: minimum (-0.20s) - default (0.00s) - maximum (1.00s)

2. SHORT ARC TIME CORRECTION

The parameter corrects the synergic value of the short arc time.

Adjustment range: minimum (-0.20s) - default (0.00s) - maximum (1.00s)

3. SHORT ARC WIRE SPEED CORRECTION

The parameter corrects the synergic value of the wire speed during the short arc period.

Adjustment range: minimum (0.0m/min) - default (0.0m/min) - maximum (5.0m/min)

4. SHORT ARC LENGTH CORRECTION

The parameter corrects the synergic value of the voltage.

Adjustment range: minimum (-10) - default (0.0) - maximum (+10)

6.3 SETTING THE JOB SELECTION

When the JOB SEL function is enabled, the torch trigger operates in 4 stroke or crater filling 4 stroke mode with the Bilevel functions disabled. Therefore, if jobs are saved with different modes, they are automatically shown according to these conditions (which are not saved).

The JOBS in a sequence can be scrolled through when welding is not taking place by quickly pressing and releasing the torch trigger.

Scrolling the JOBS with an UP/DOWN torch

When an UP/DOWN torch is installed, JOBS can be selected in a JOB sequence using the triggers on the welding torch. To create the JOB sequence, leave a free memory slot before and after the group of JOBS to be included in the sequence.

Sequence 1			JOB not saved	Sequence 2			JOB not saved	Sequence 3		
J.01	J.02	J.03		J.05	J.06	J.07		J.09	J.10	J.11

Select and load one of the JOBS in the desired sequence (for example J.06).

By using the torch UP/DOWN keys, all the JOBS in sequence 2 can be scrolled (J.05,J.06,J.07).

When the torch UP/DOWN key is pressed again, the arc length can be changed.

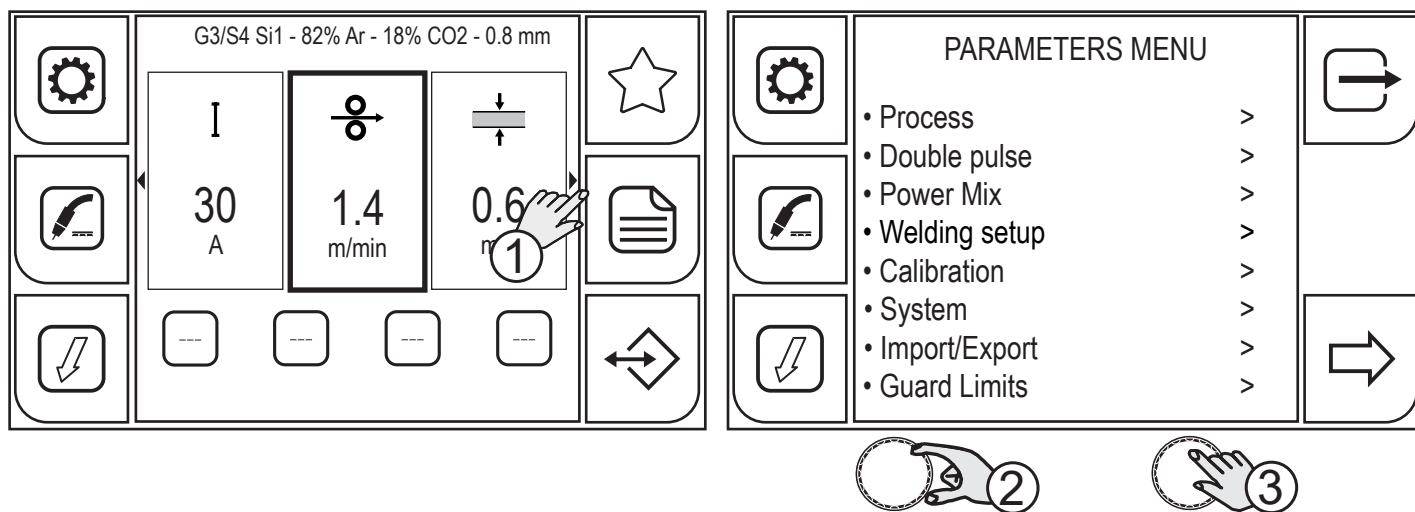

1. Press the (MENU) key.
2. Turn the encoder to select the desired item. Select the following path: Welding setup>
3. Press the key (ENCODER) to confirm your selection.

ENGLISH

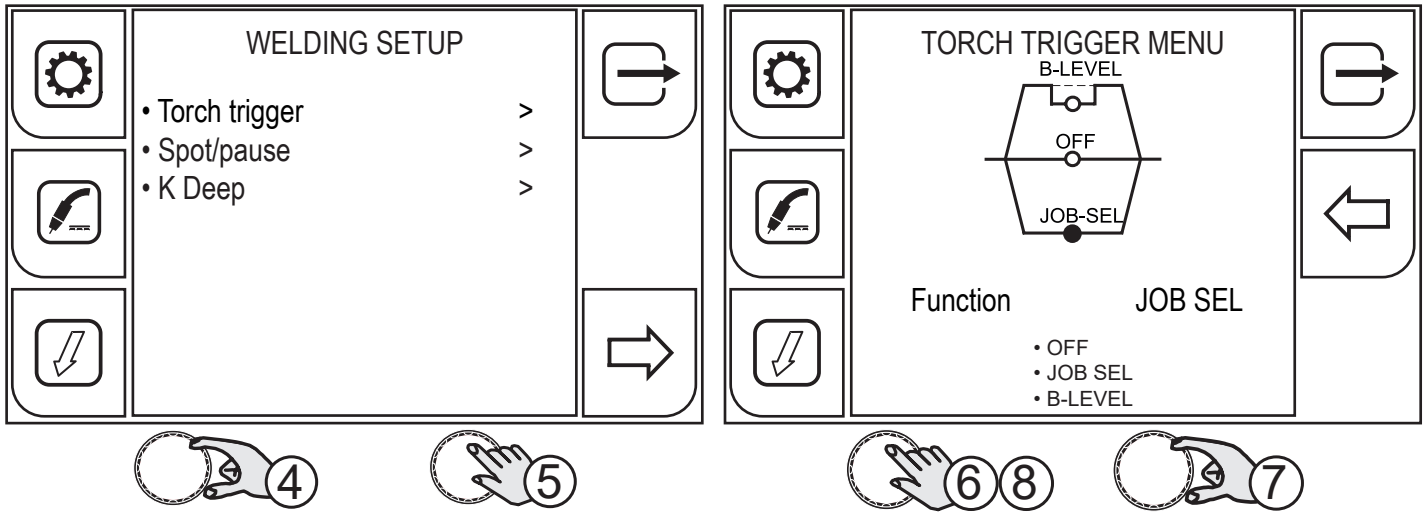

4. Turn the encoder to select the desired item. Select the following path: Torch trigger>
5. Press the (ENCODER) key to confirm your selection.
6. Press the (ENCODER) key to enable function selection.
7. Turn the encoder to select the JOB SEL function.
8. Press the (ENCODER) key to confirm your selection.

Press the (PREC) key to return to the previous screen.

To return to the main screen, press the (EXIT) key.

6.4 SETTING THE B-LEVEL

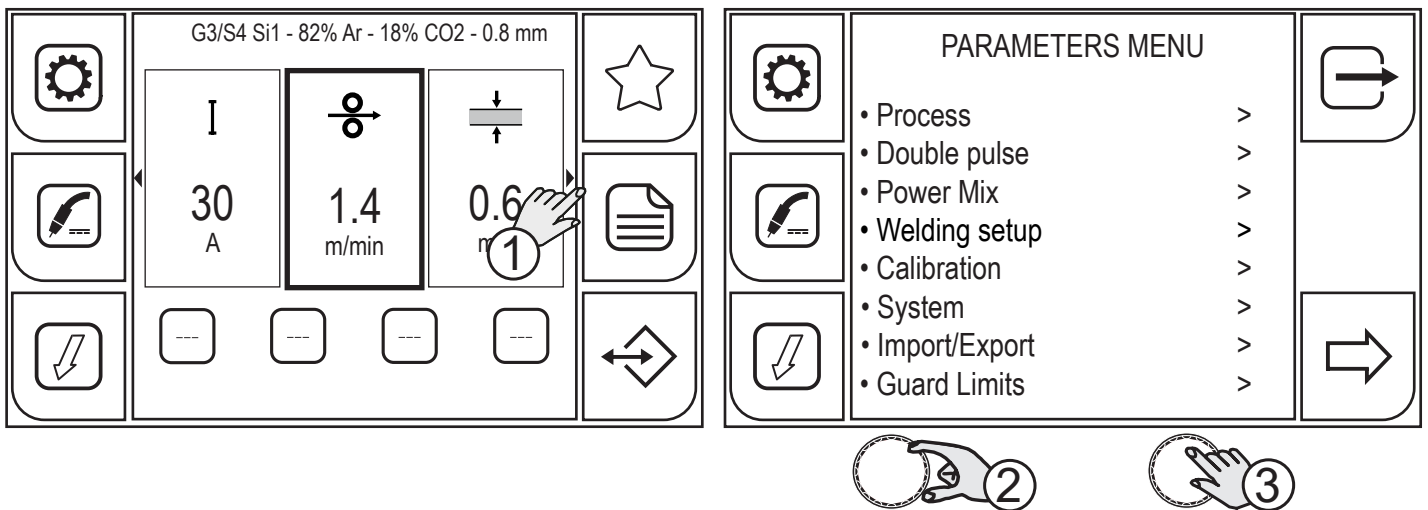

1. Press the (MENU) key.
2. Turn the encoder to select the desired item. Select the following path: Welding setup>
3. Press the (ENCODER) key to confirm your selection.

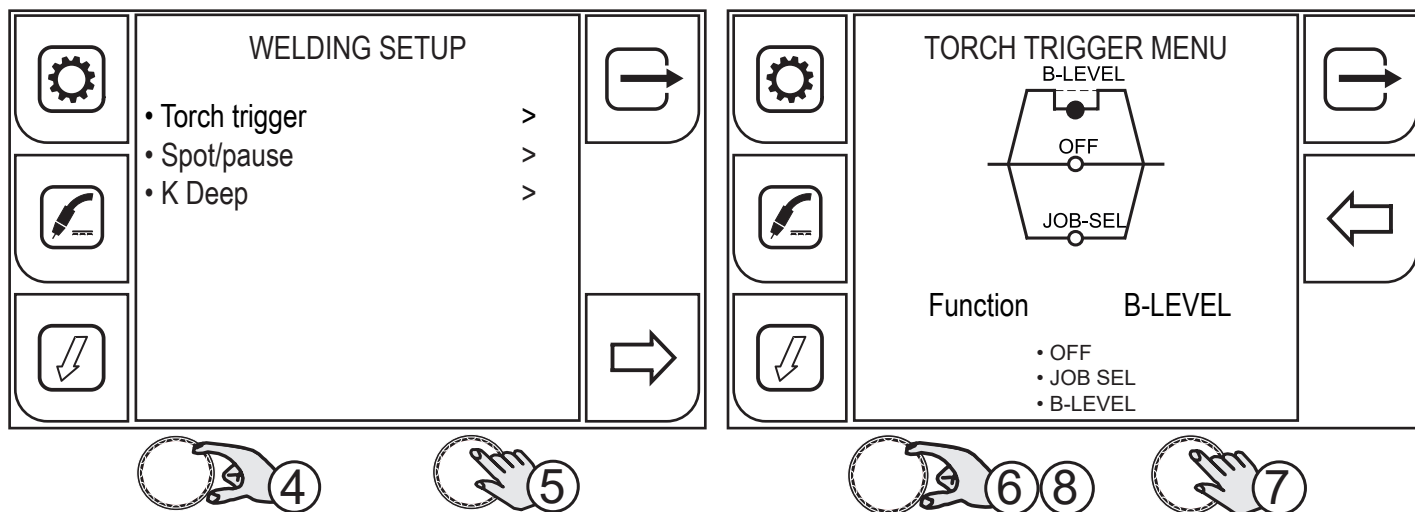

4. Turn the encoder to select the desired item. Select the following path: Torch trigger>
5. Press the (ENCODER) key to select the function.
6. Turn the encoder to select the B-LEVEL function.
7. Press the (ENCODER) key to confirm your selection.
8. Turn the encoder to view the B-level parameter symbol.

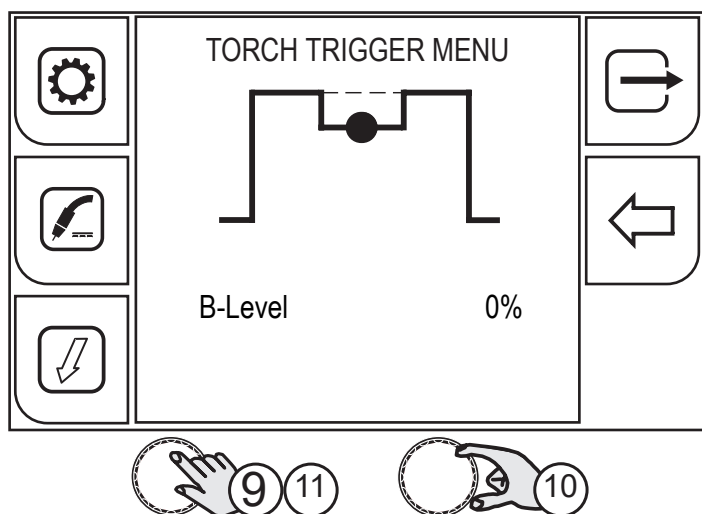

9. Press the (ENCODER) key enable the parameter change.
10. Turn the encoder to set the desired value.
11. Press the (ENCODER) key to confirm your selection.

Press the (PREC) key to return to the previous screen.

To return to the main screen, press the (EXIT) key.

B-LEVEL CURRENT

- The parameter enables a special torch trigger function.
- Pressing and releasing the torch trigger rapidly in welding mode (in 2nd stroke) switches from the main welding current to a secondary current.

- Pressing and releasing the torch trigger again switches from the secondary current to the main current. This switching can be performed repeatedly at the discretion of the operator.
- To close the welding cycle (3rd stroke) press the torch trigger for a longer period of time. When the trigger is released the welding cycle will be closed (4th stroke).

Available range: minimum (0 %) - default (0 %) - maximum (100 %)

6.5 SETTING THE SPOT/PAUSE FUNCTION

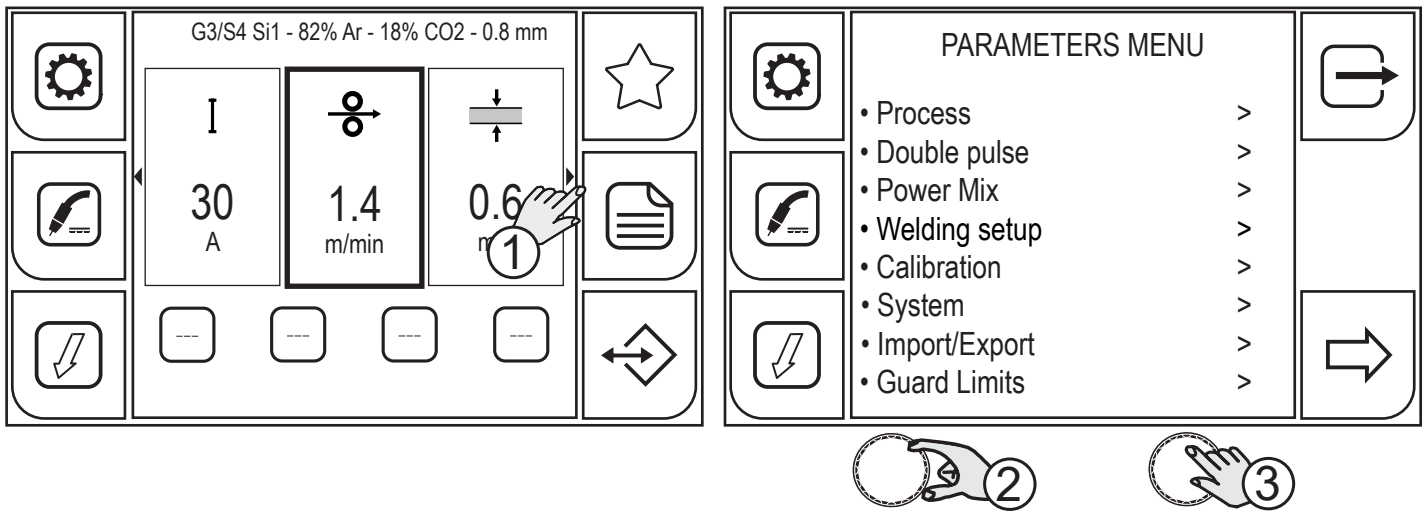

1. Press the (MENU) key.
2. Turn the encoder to select the desired item. Select the following path: Welding setup>
3. Press the (ENCODER) key to confirm your selection.

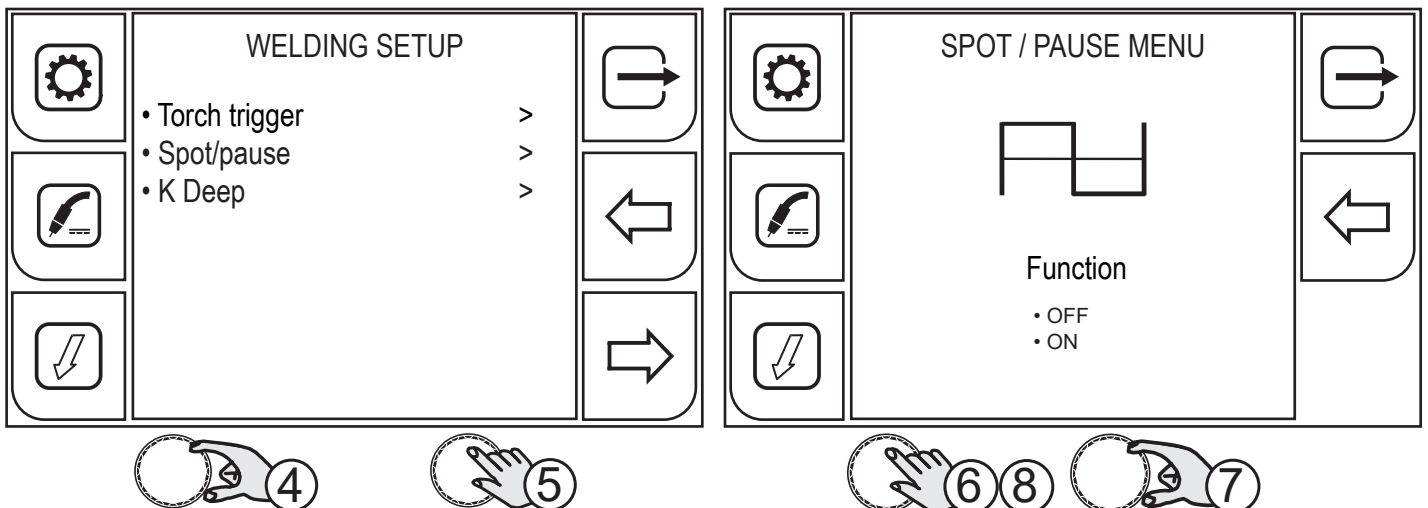

4. Turn the encoder to select the desired item. Select the following path: Spot/pause>
5. Press the (ENCODER) key to confirm your selection.
6. Press the (ENCODER) key to select the function.
7. Turn the encoder to select the desired item. Select the following path: ON
8. Press the (ENCODER) key to confirm your selection.

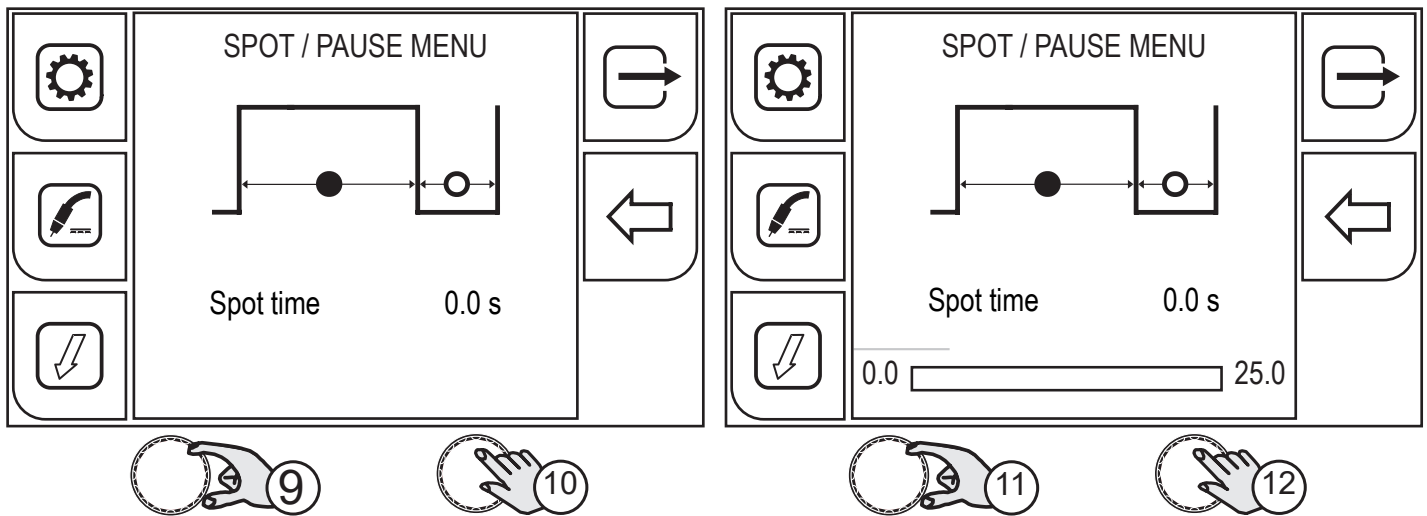

9. Turn the encoder to select the desired parameter.
10. Press the (ENCODER) key to apply the parameter change.
11. Turn the encoder to set the desired value.
12. Press the (ENCODER) key to confirm your selection.

Press the  (PREC) key to return to the previous screen.

To return to the main screen, press the  (EXIT) key.

SPOT WELDING TIME

When the torch trigger is pressed the welding arc persists for the time set in the parameter.

Press the torch trigger again to resume the welding process.

The welding process cannot be interrupted once it has been started.

When the torch trigger is pressed, if the arc does not strike within 10 seconds, the process is deactivated.

The welding parameters can be modified during the welding process.

Adjustment range: minimum (0.0 s) - default (0.0 s) - maximum (25.0 s)

PAUSE TIME

The parameter sets the pause time after the spot pulse.

Adjustment range: minimum (0.0 s) - default (0.0 s) - maximum (25.0 s)

6.6 K DEEP PROCEDURE SETUP

The procedure can be enabled when an HC curve has been loaded.

K DEEP is a procedure aiming at stabilising penetration and uses the wire speed variation to keep the arch height constant and obtain a more uniform weld bead as regards width and depth.

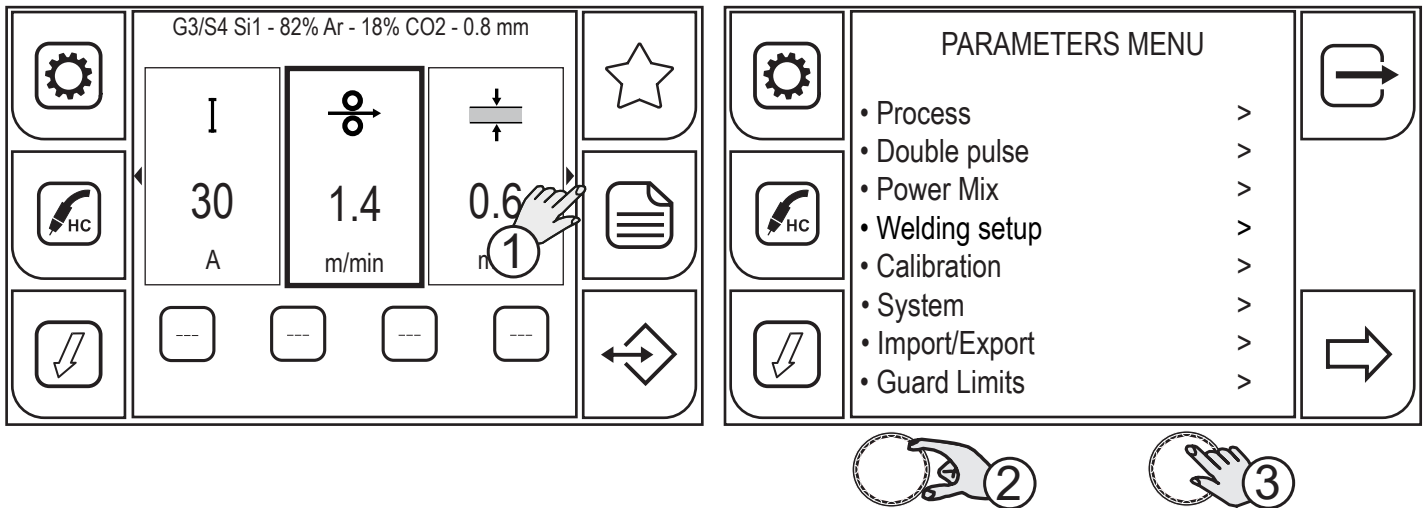

1. Press the (MENU) key.
2. Turn the encoder to select the desired item. Select the following path: Welding setup>
3. Press the (ENCODER) key to confirm your selection.

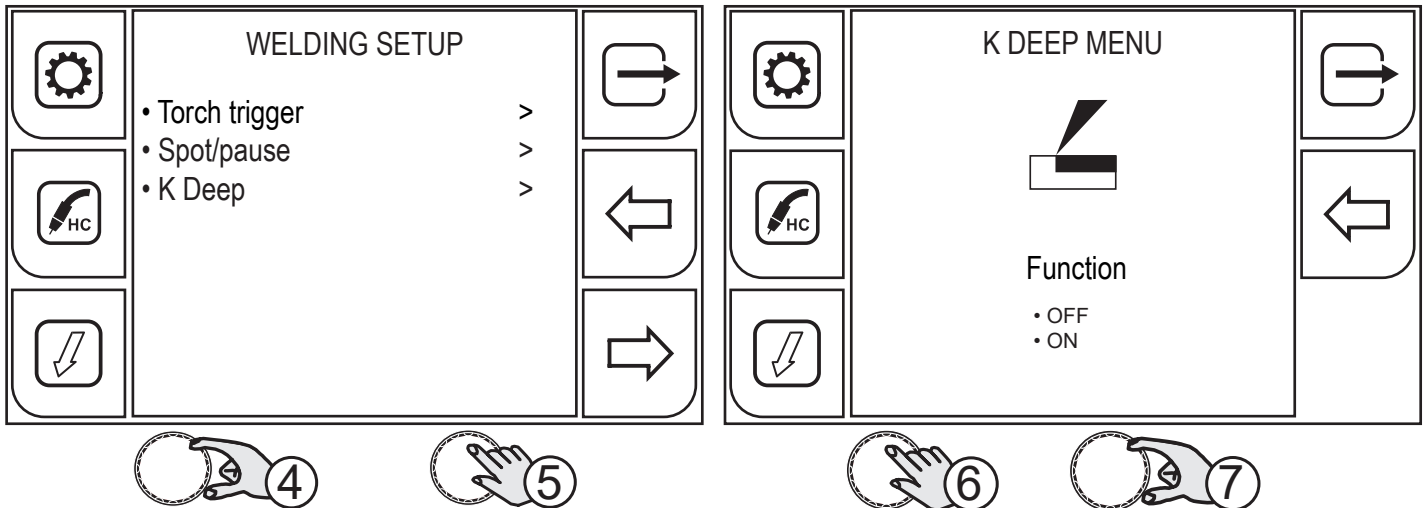

4. Turn the encoder to select the desired item. Select the following path: K Deep>
5. Press the (ENCODER) key to confirm your selection.
6. Press the (ENCODER) key to enable function selection.
7. Turn the encoder to select the desired item. Select the following path: ON

Press the (PREC) key to return to the previous screen.

To return to the main screen, press the (EXIT) key.

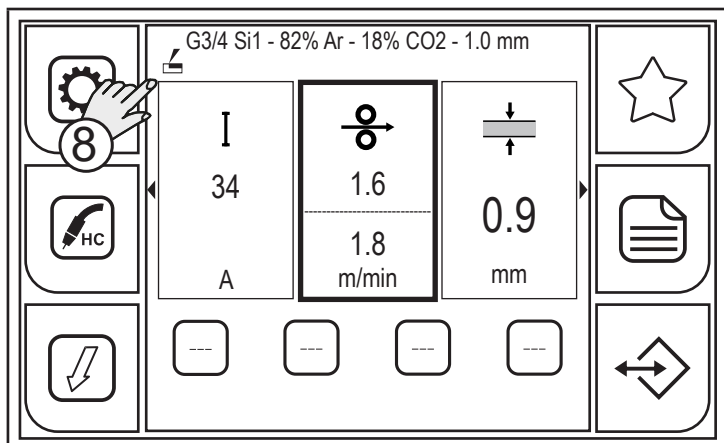

8. Below the active synergic curve wording, the icon of the active K DEEP procedure will appear. The WIRE SPEED parameters window is divided into two sections; the value set by the user is displayed in the upper section, while the actual output value is displayed in the lower section.

6.7 SETTING DSI (Digital Sense Ignition) PROCEDURE

The procedure can be enabled when an HC curve has been loaded.

Digital Sense Ignition enables wire spatter and explosions to be almost totally eliminated during the cold ignition phase and during energy transmission to the workpiece. DSI enables:

- splashes onto stainless steel to be reduced by 60% during the ignition phase
- splashes onto carbon steel to be reduced by 30% during the ignition phase
- ignition with short-circuited wire to be optimized with significant reduction of splashes and explosions.

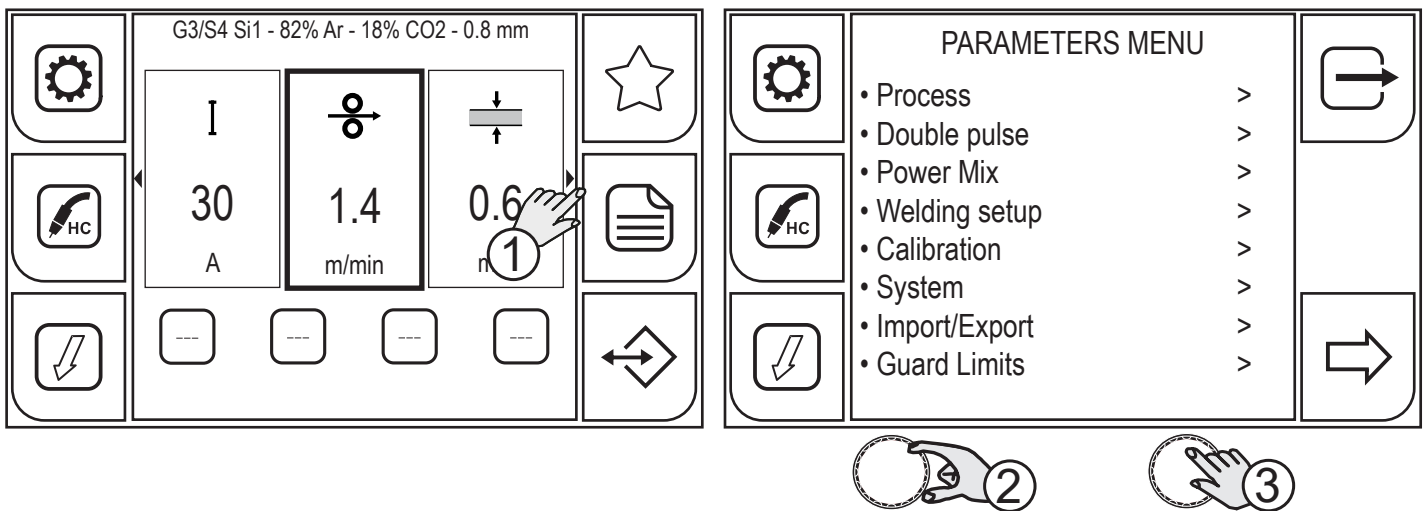

1. Press the (MENU) key.
2. Turn the encoder to select the desired item. Select the following path: Welding setup>
3. Press the (ENCODER) key to confirm your selection.

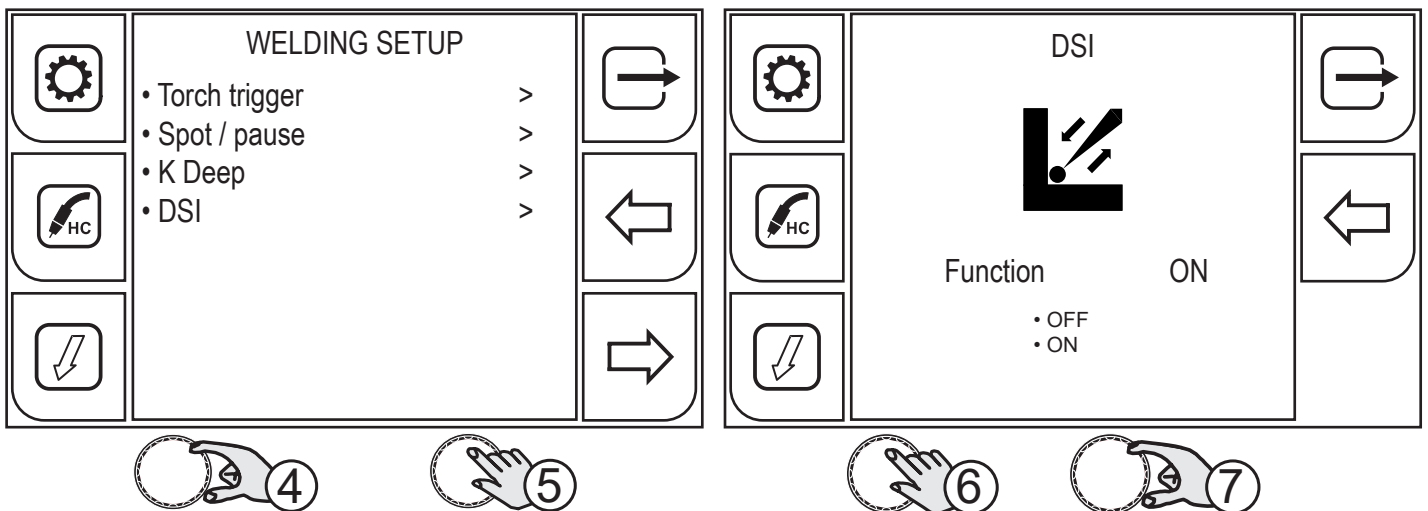

4. Turn the encoder to select the desired item. Select the following path: K Deep>
5. Press the (ENCODER) key to confirm your selection.
6. Press the (ENCODER) key to enable function selection.
7. Turn the encoder to select the desired item. Select the following path: ON

Press the (PREC) key to return to the previous screen.

To return to the main screen, press the (EXIT) key.

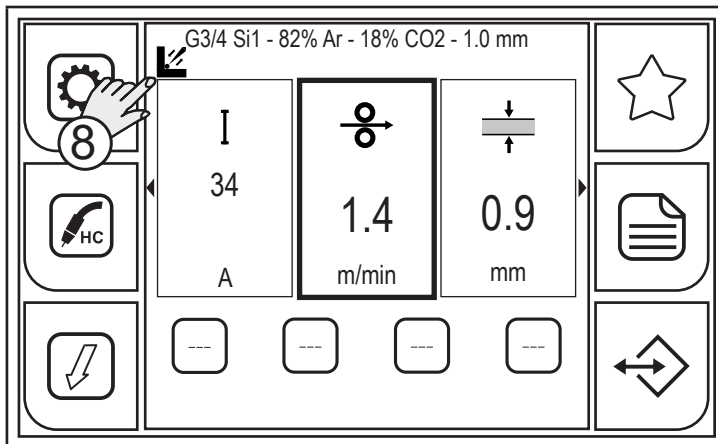

8. Below the active synergic curve wording, the icon of the active DSI procedure will appear.

7 MMA WELDING

7.1 SETTING THE MMA PROCESS

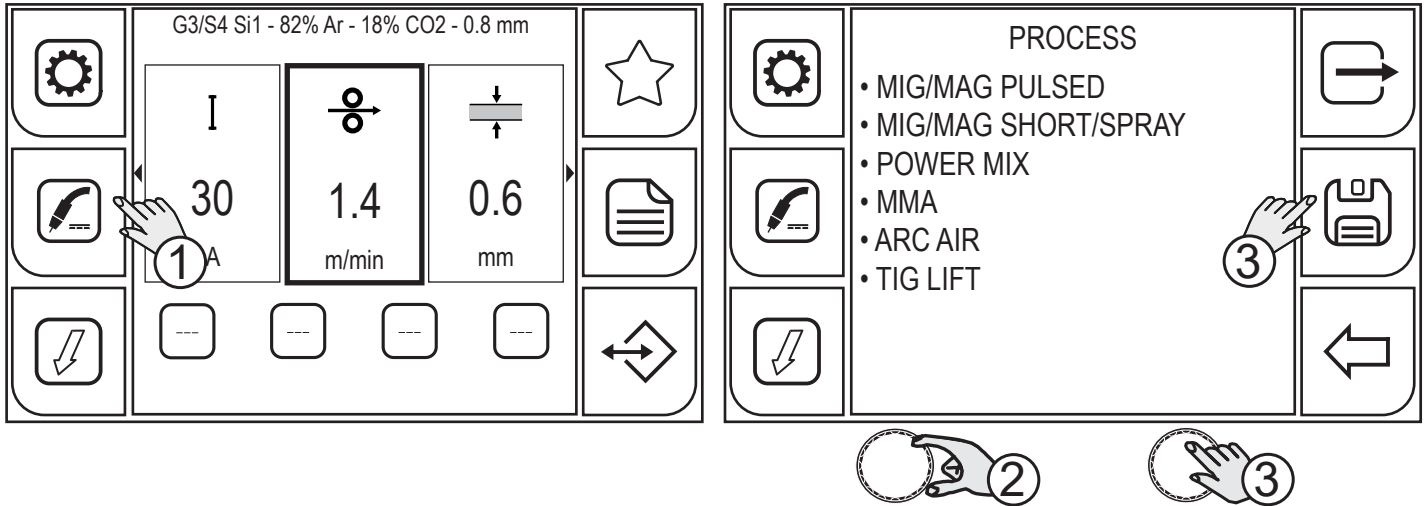

1. Press the (PROCESS) key.
2. Turn the encoder to select the desired setting. Select the following path: MMA
3. Press the (ENCODER) key or the (SAVE) key to confirm.

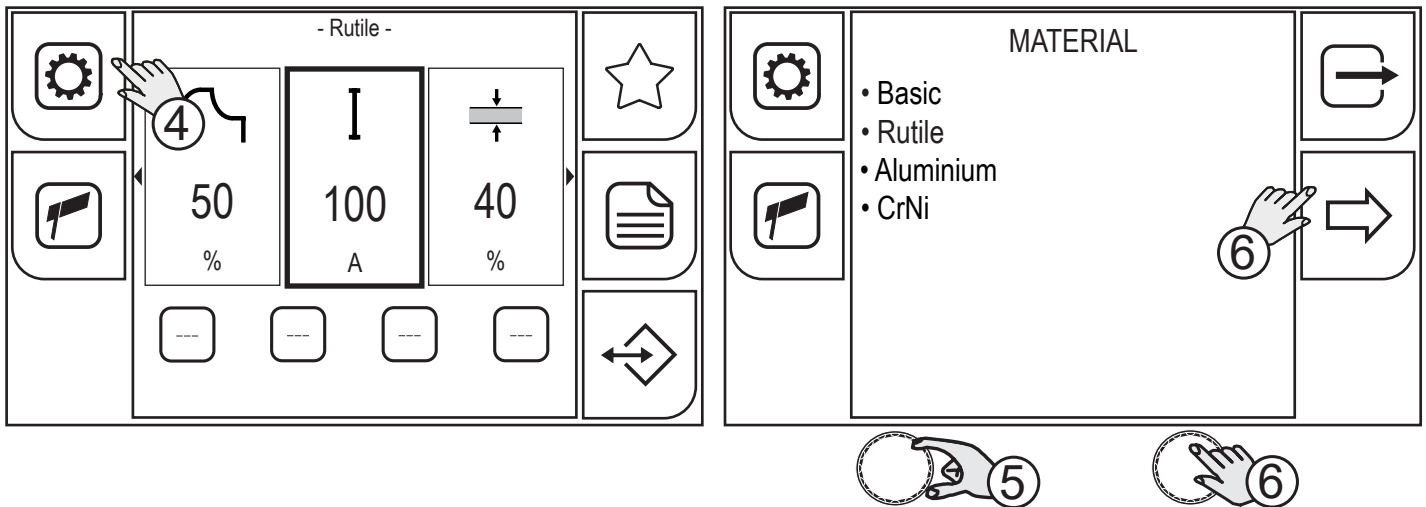

4. Press the (PROGRAM) key.
5. Turn the encoder to select the desired setting.
 - o (Basic, Rutile, Aluminium, CrNi)
6. Press the (ENCODER) key or the (NEXT) key to confirm.

Press the  key to exit the screen.

7.2 SETTING THE PROCESS PARAMETERS

The  (PARAMETERS MENU) key allows the user to access the menu used to set the main welding features.

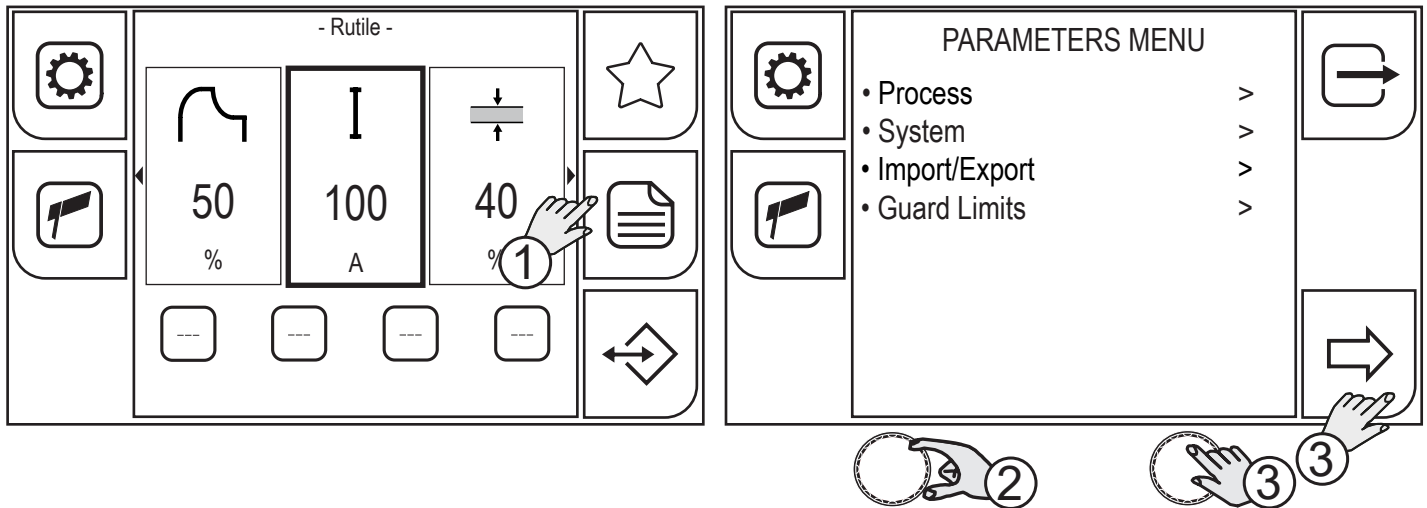

1. Press the (MENU) key.
2. Turn the encoder to select the desired setting. Select the following path: Process>
3. Press the (ENCODER) key or the (NEXT) key.

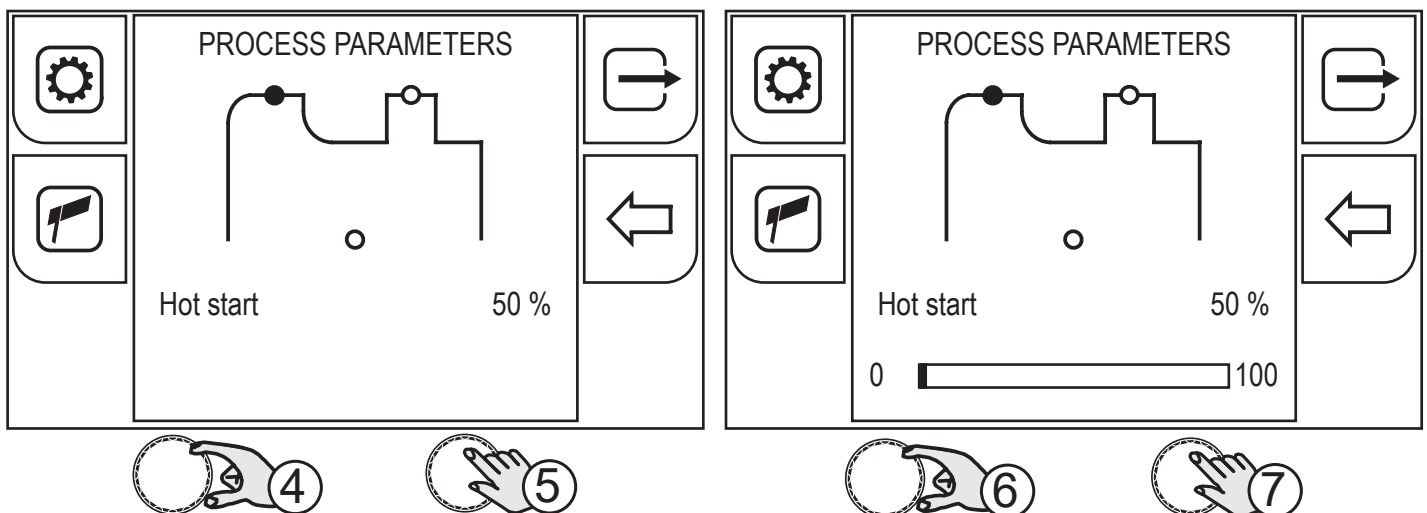

4. Turn the encoder to select the parameter to be changed.
5. Press the (ENCODER) key to confirm your selection.
6. Turn the encoder to set the desired value.
7. Press the (ENCODER) key to confirm your selection.

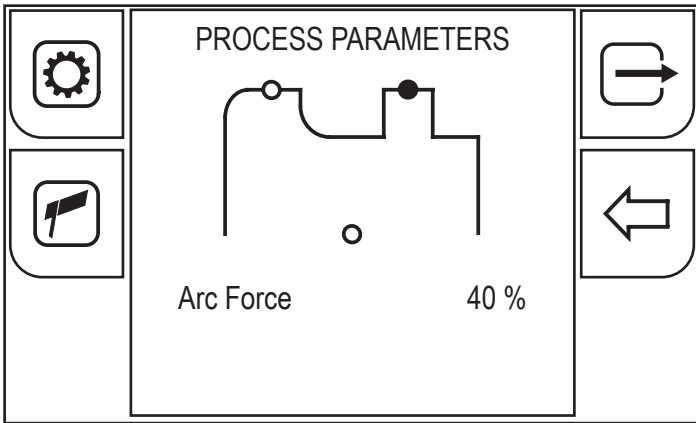

8. Turn the encoder again to select other parameters.

To return to the main screen, press the  (EXIT) key.

7.2.1 MMA PARAMETERS (PARAMETRESMENU)

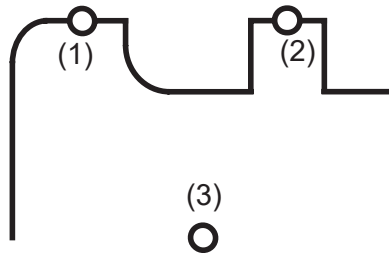

1. HOT START

This parameter aids electrode melting at the time of arc striking. It is set as a percentage referred to the value of the WELDING CURRENT. The value is limited to 250A max.

Adjustment range: minimum (0 %) - default (50 %) - maximum (100 %)

2. ARC FORCE

This parameter helps to avoid electrode sticking during welding. It is set as a percentage referred to the value of the WELDING CURRENT.

Adjustment range: minimum (0 %) - default (40 %) - maximum (200 %)

3. VOLT END

The parameter sets the voltage value once the welding process is exited by lifting the electrode. To exit the MMA welding process the electrode must be lifted considerably; set the parameter at a low value to stop the welding process by slightly lifting the electrode. In this way, less welding spatters are produced and the workpiece is cleaner.

Be careful when setting the parameter because a too low value can lead to frequent welding interruptions.

Adjustment range: minimum (20 V) - default (50 V) - maximum (70 V)

7.2.2 MMA PARAMETERS (MAIN SCREEN)

The following welding parameters can be set on the main screen in addition to the parameters menu.

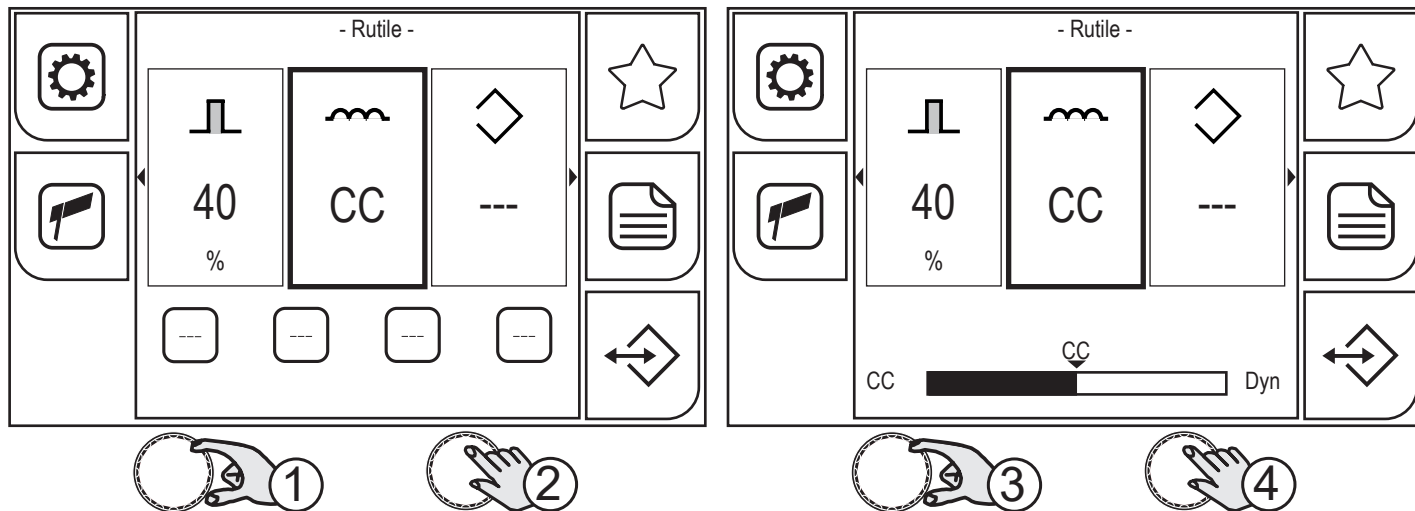

1. Turn the encoder to select the parameter to be changed.
2. Press the (ENCODER) key to confirm your selection.
3. Turn the encoder to set the desired value.
4. Press the (ENCODER) key to confirm your selection.

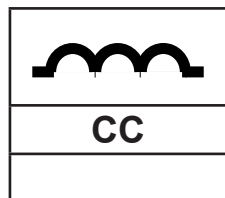

INDUCTANCE

A low-value parameter allows to obtain a softer arc and fewer spatters while a higher value allows to obtain an harder and more stable arc.

With "CC" (constant current) setting, preset welding current is constantly output. This setting is recommended for welding processes with basic, rutile and stainless steel electrodes.

With "Dyn" setting, the current output remains constant (the arc tension increases and the current output decreases when the electrode is lifted).

This setting is recommended for welding processes with cellulose electrodes to carry out route passes onto pipes and with aluminium electrodes to improve arc stability especially at reduced current values.

Adjustment range: minimum (CC constant current) - default (CC) - maximum (Dyn)

Turn the encoder again to select other parameters.

8 ARC AIR WELDING

8.1 SETTING THE ARC AIR PROCESS

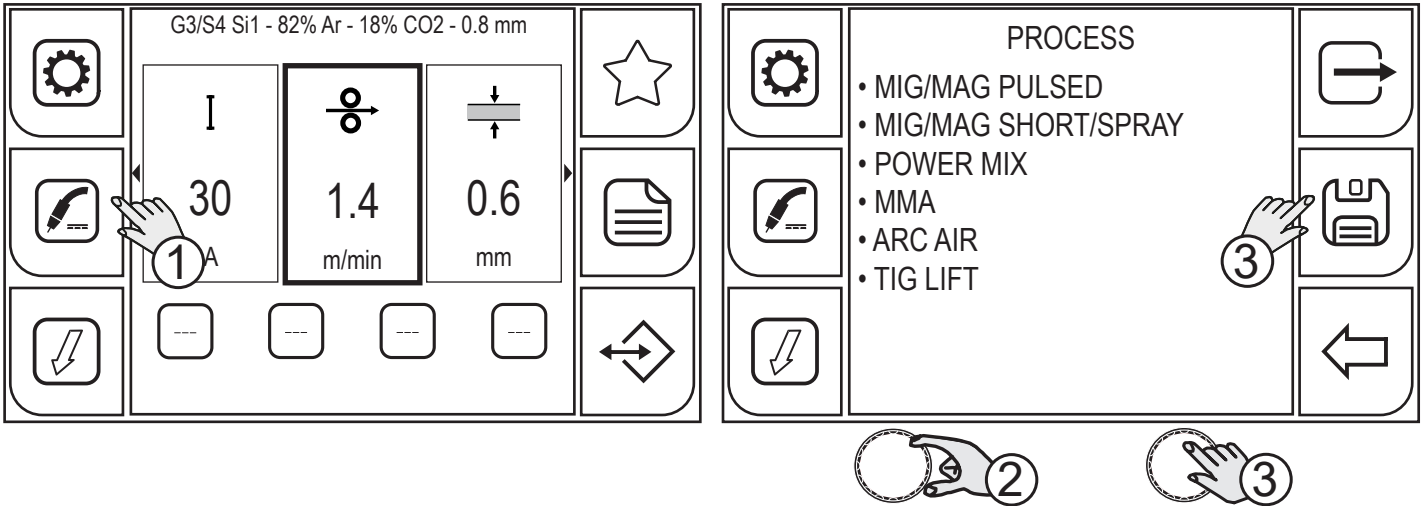

1. Press the (PROCESS) key.
2. Turn the encoder to select the desired setting. Select the following path: ARC AIR
3. Press the (ENCODER) key or the (SAVE) key to confirm.

8.2 SETTING THE PROCESS PARAMETERS

The  (PARAMETERS MENU) key allows the user to access the menu used to set the main welding features.

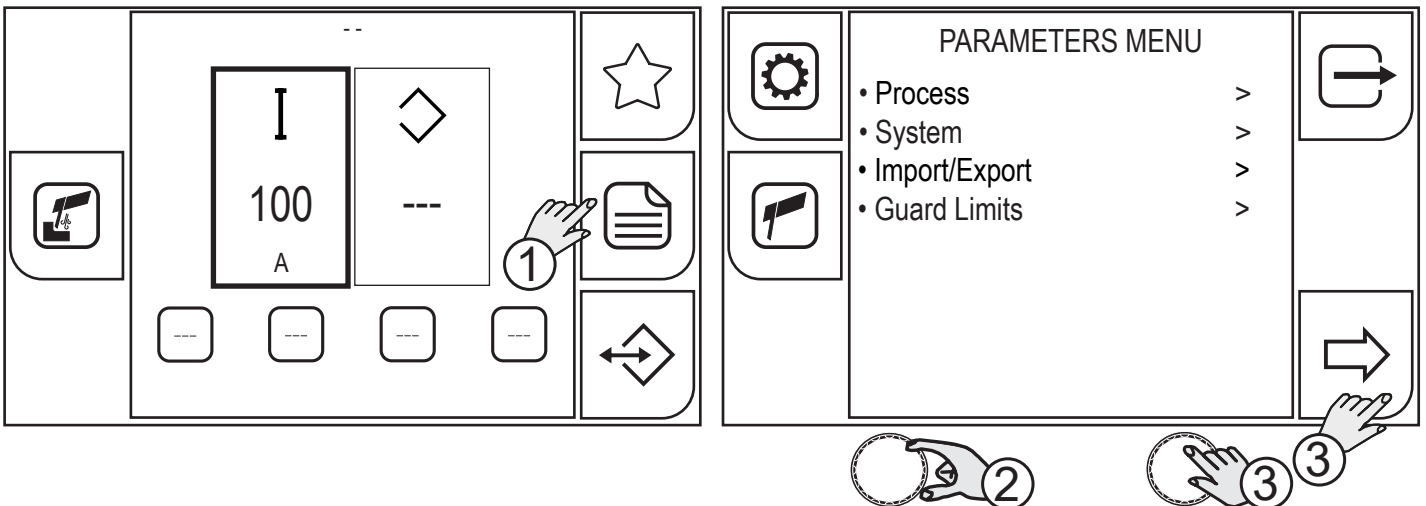

1. Press the (MENU) key.
2. Turn the encoder to select the desired setting. Select the following path: Process>
3. Press the (ENCODER) key or the (NEXT) key.

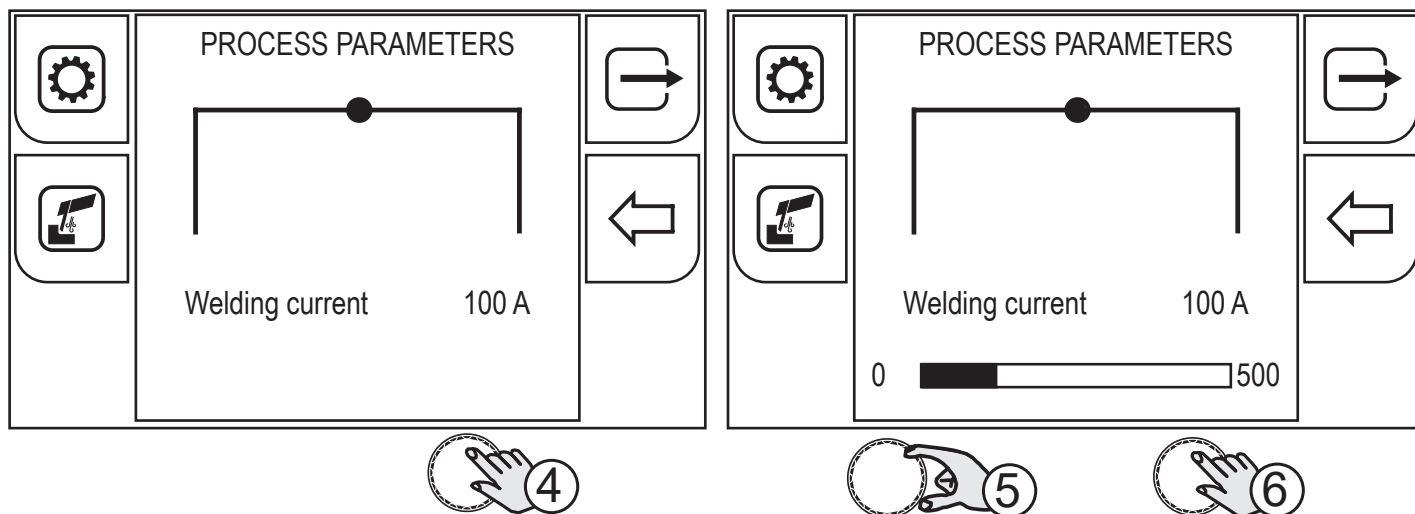

4. Press the (ENCODER) key to confirm your selection.
5. Turn the encoder to set the desired value.
6. Press the (ENCODER) key to confirm your selection.

To return to the main screen, press the  (EXIT) key.

9 TIG LIFT WELDING

9.1 SETTING THE TIG LIFT PROCESS

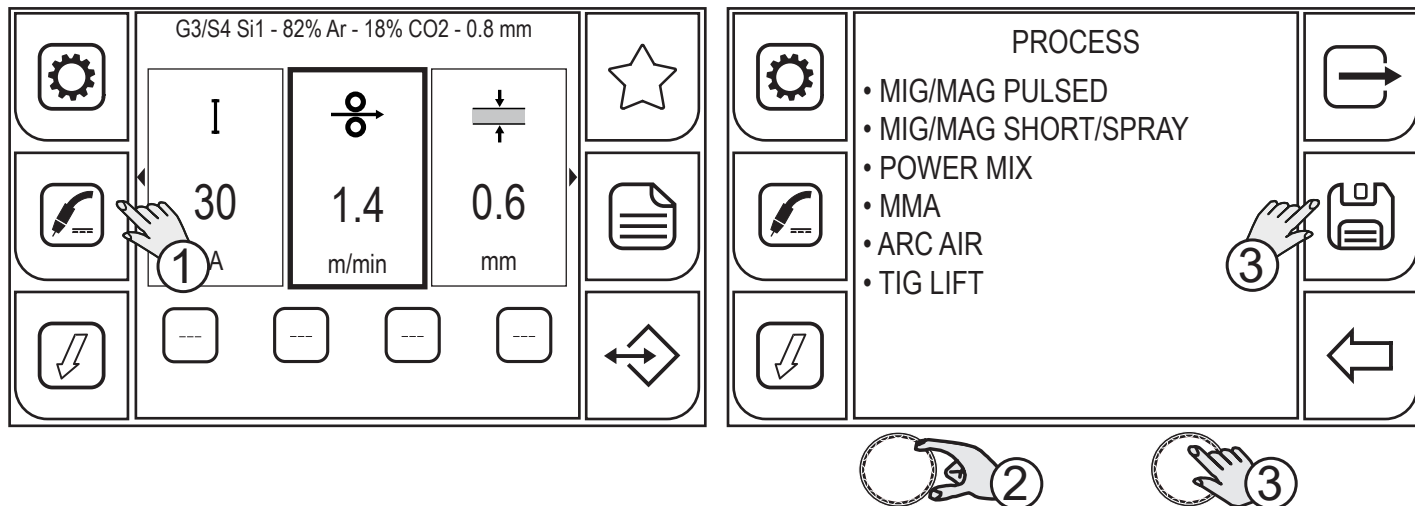

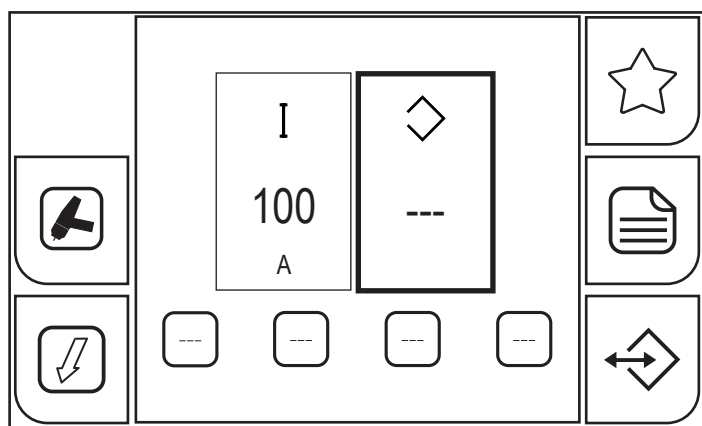

1. Press the (PROCESS) key.
2. Turn the encoder to select the desired setting. Select the following path: TIG LIFT
3. Press the (ENCODER) key or the (SAVE) key to confirm.

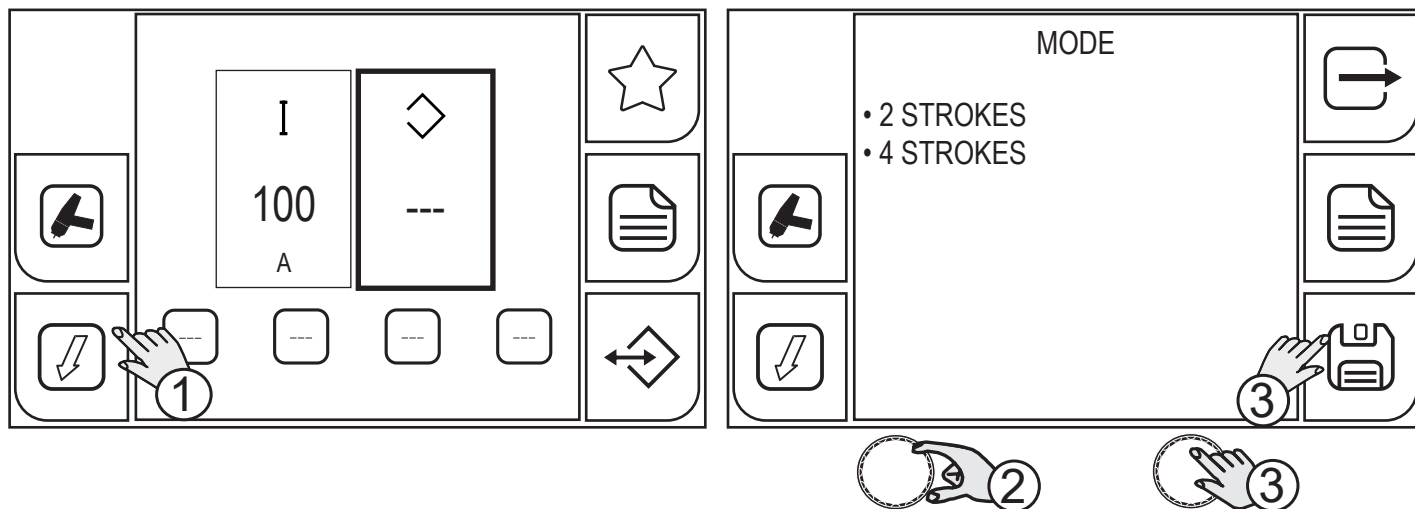

Press the  key to exit the screen.

9.2 SETTING UP THE TIG TORCH TRIGGER MODE



1. Press the (MODE) key.
 - From within the menu screen, the torch trigger mode can be selected.
-  (2 STROKES) -  (4 STROKES)
2. Turn the encoder to select the desired setting.
 3. Press the (ENCODER) key or the (SAVE) key to only set up the torch trigger mode, otherwise carry out the procedure shown in paragraph (4).

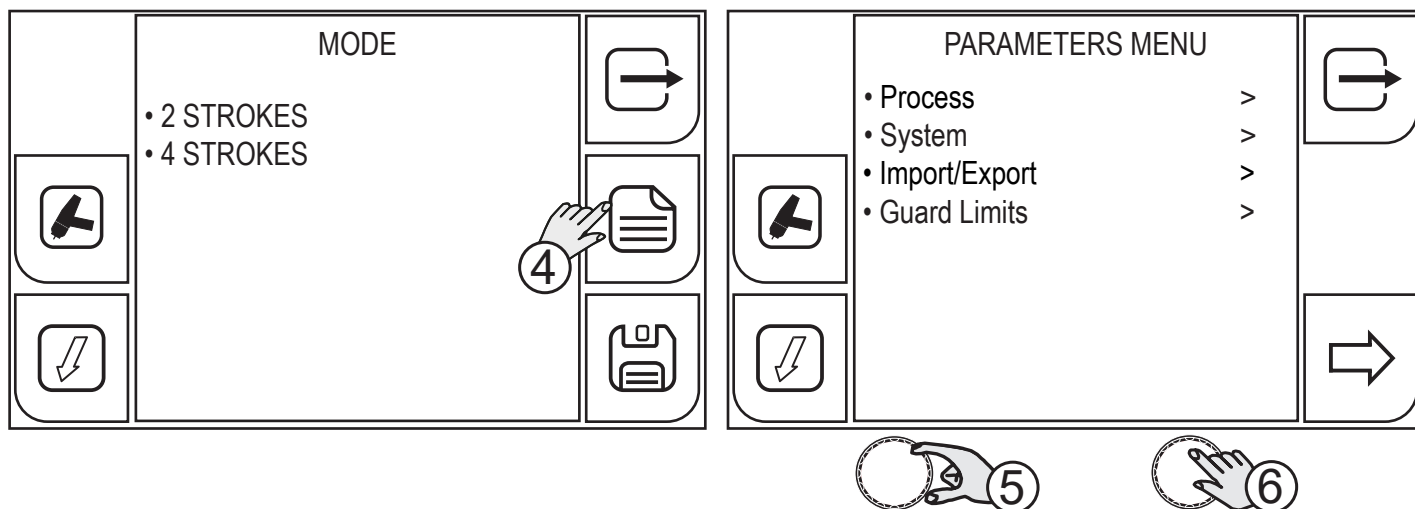

4. Press the (MENU) key.
5. Turn the encoder to select the desired setting. Select the following path: Process>
6. Press the (ENCODER) key or the (NEXT) key.

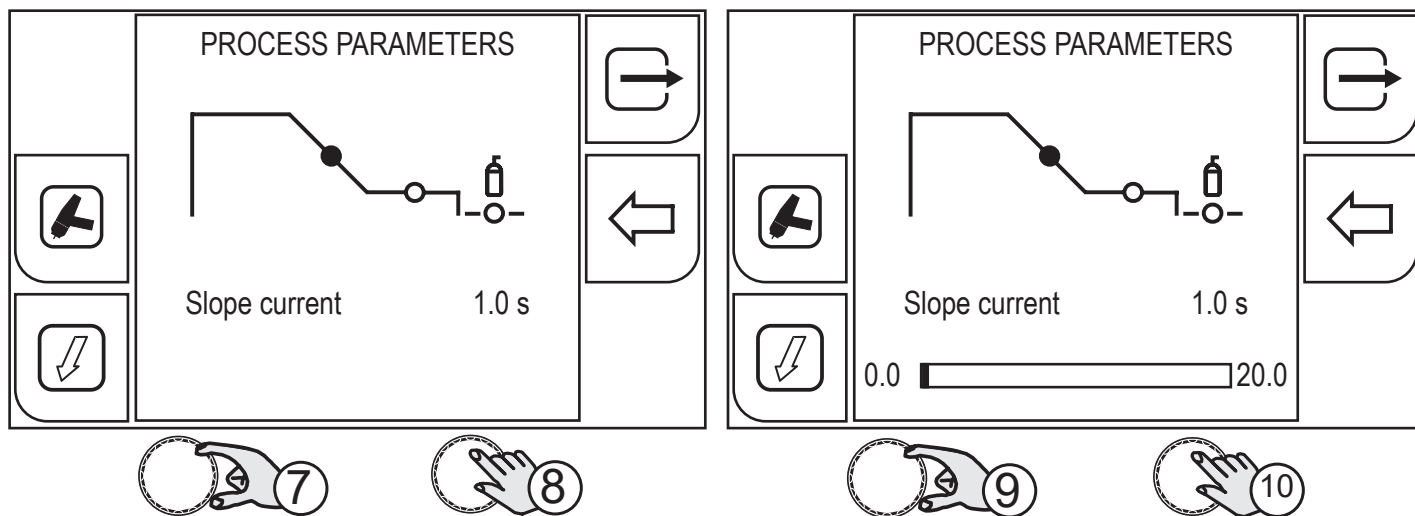

7. Turn the encoder to select the parameter to be changed.
8. Press the (ENCODER) key to confirm your selection.
9. Turn the encoder to set the desired value.
10. Press the (ENCODER) key to confirm your selection.

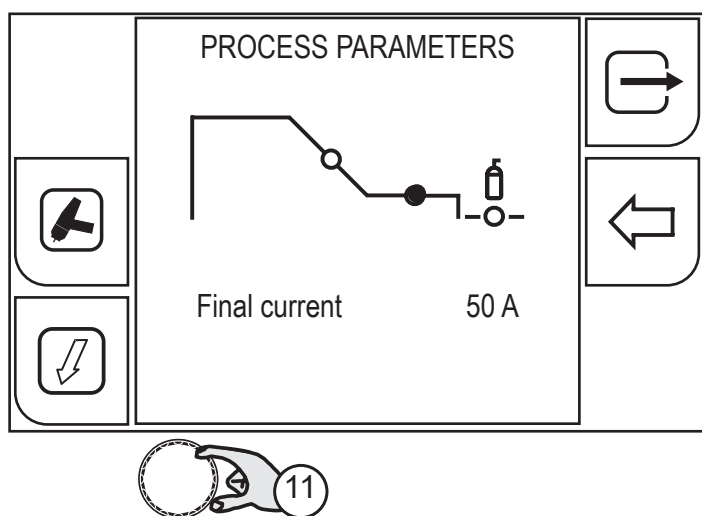

11. Turn the encoder again to select other parameters.
- To return to the main screen, press the  (EXIT) key.

9.2.1 PROCESS PARAMETERS WITH TORCH TRIGGER IN 2 STROKE AND 4 STROKE MODE

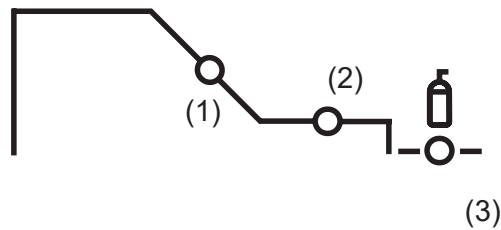

1. SLOPE CURRENT

The parameter sets the time during which the current changes from the welding value to the end value by means of a slope. Prevents the formation of craters in the process of turning off the arc.

Adjustment range: minimum (0.0 s) - default (1.0 s) - maximum (20.0 s)

2. FINAL CURRENT

The parameter sets the final current value. During electrode welding the parameter makes it possible to obtain a uniform deposit of filler material from the start to the end of the welding process, closing the deposition crater with a current such as to deposit a final droplet of filler material.

Adjustment range: minimum (0 A) - default (50 A) - maximum (500 A)

3. POST GAS

Time of post gas delivery when the welding arc is extinguished.

Adjustment range: minimum (0.0 s) - default (2.0 s) - maximum (20.0 s)

9.2.2 TIG LIFT 2T OPERATION

- ↓ : press the torch trigger
- ↑ : release the torch trigger

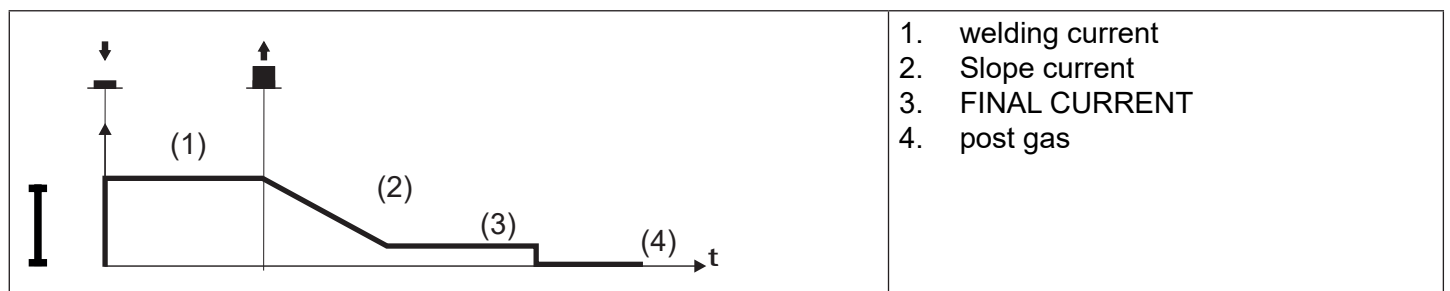

- Touch the workpiece with the torch electrode.
- Press (1T) and keep the torch trigger pressed.
- Slowly lift the torch to strike the arc.
- The welding current reaches the preset value.
- Release (2T) trigger to start the weld completion procedure.
- The current reaches the end current value in the time set in the down slope time parameter.
- The arc is extinguished.
- Gas delivery continues for the time set in the post gas parameter.

9.2.3 TIG LIFT 4T OPERATION

- ↓ : press the torch trigger
- ↑ : release the torch trigger
- ↑↓ : press and release the torch trigger

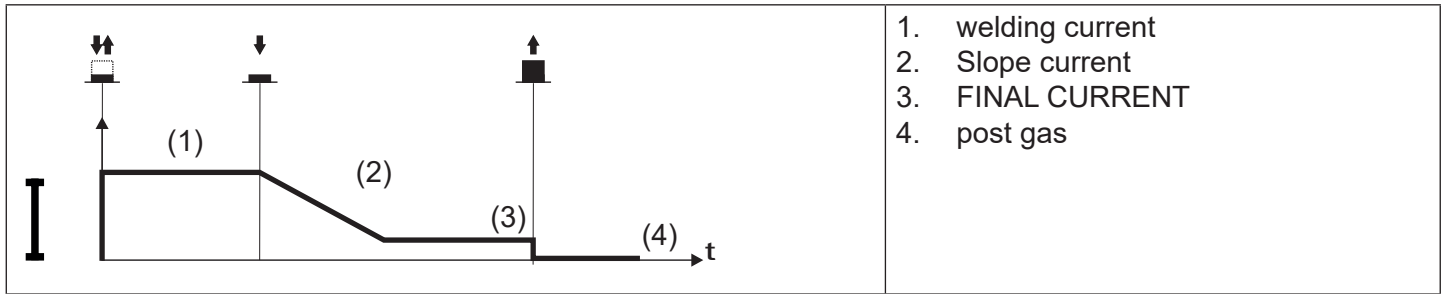

- Touch the workpiece with the torch electrode.
- Press (1T) and release (2T) the torch trigger.
- Slowly lift the torch to strike the arc.
- The welding current reaches the preset value.
- Press (3T) trigger and keep it pressed to start the weld completion procedure.
- The current reaches the end current value in the time set in the down slope time parameter.
- The arc continues and the current output will be the value set in the end current parameter.
- In these conditions the weld pool can be closed (crater filler current).
- Release (4T) trigger to extinguish the arc.
- Gas delivery continues for the time set in the post gas parameter.

10 JOBS MANAGEMENT

Personalised welding settings, or JOBS, can be saved in memory locations and subsequently uploaded. The Job entails saving the image of all the parameters set in the device. The device parameters are: wire speed, welding arc correction, inductance/dynamic, slopes, torch button mode, process, program used, special functions, guard limits etc...

The settings of the SETUP menu are not saved.

100 JOBS are available.

This function is available when welding mode is not active.

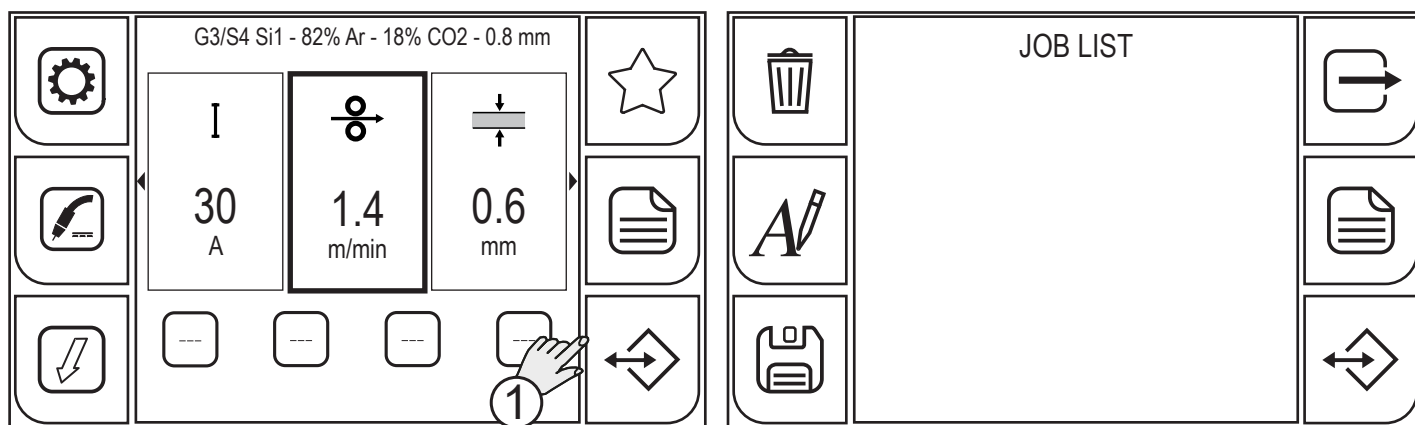

1. To enter the JOB menu, press the (JOB) key.

10.1 CREATING A JOB

Enter the JOB screen.

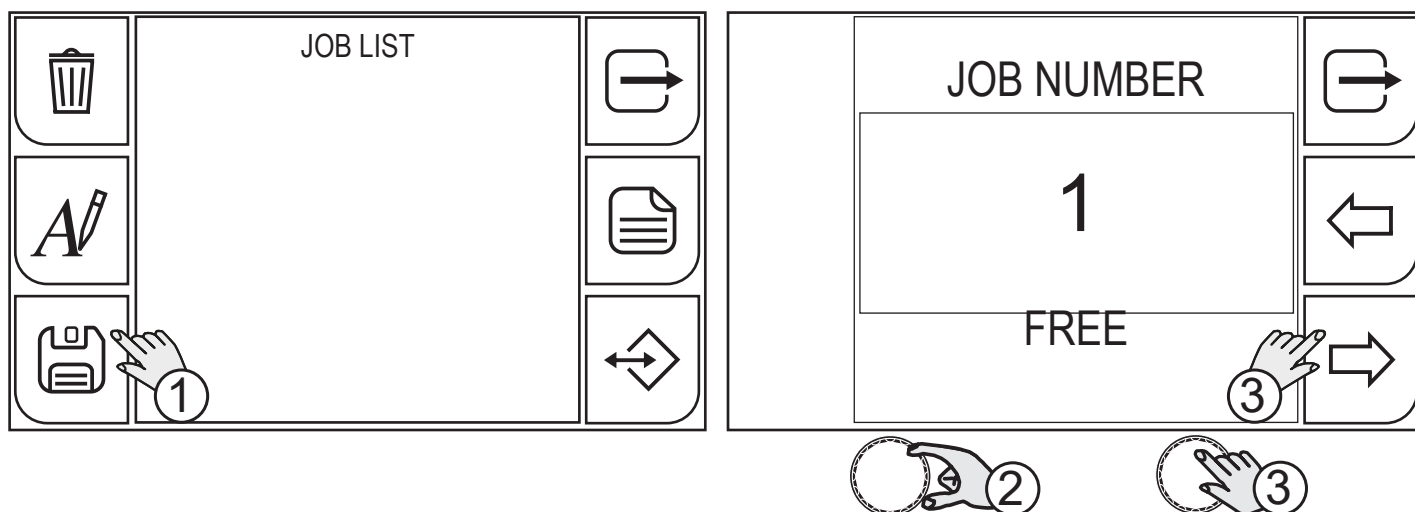

1. Press the (CREATE JOB) key. The JOB position selection screen will appear.
2. By using the encoder select the JOB position.
3. Press the (ENCODER) key or the (NEXT) key. The keyboard will appear to write the name of the job.

ENGLISH

10.1.1 KEYBOARD FUNCTIONS

1. exiting without saving changes
2. JOB position
3. JOB name
4. upper-case
5. numbers/special characters
6. space bar
7. delete text
8. save

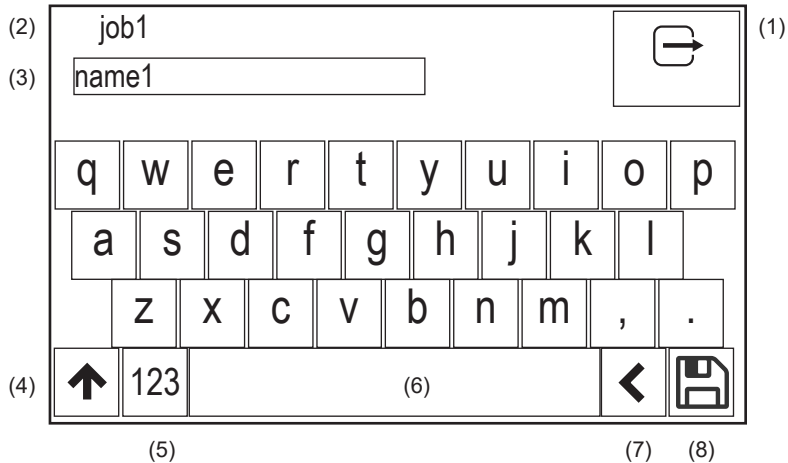

The touchscreen panel allows the welder to set up the functions through the mechanical keys or by touching the icons displayed on the screen.

10.1.2 NAMING A JOB

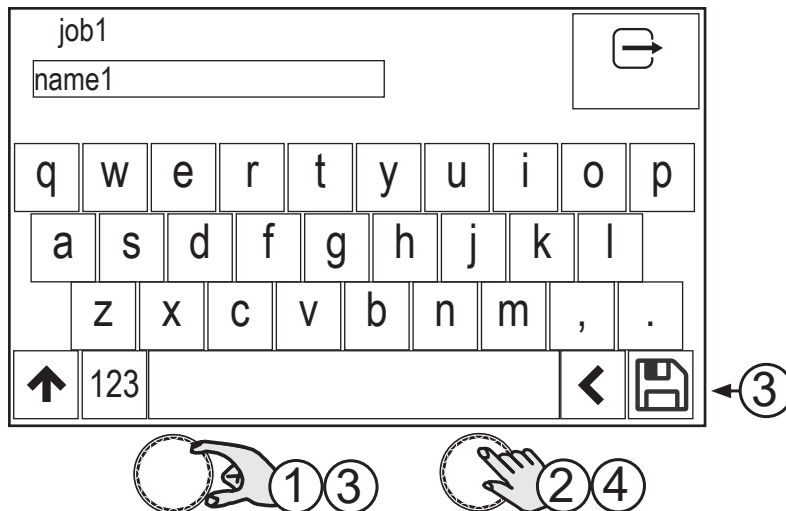

1. Turn the encoder to select the letter on the keyboard.
2. Press the (ENCODER) key to confirm your selection.
3. Turn the encoder to select the (SAVE) symbol on the keyboard
4. Press the (ENCODER) key to save and exit.

Press the key  to exit without saving.

10.2 RENAMING A JOB

Enter the JOB screen, which contains the list of stored JOBS.

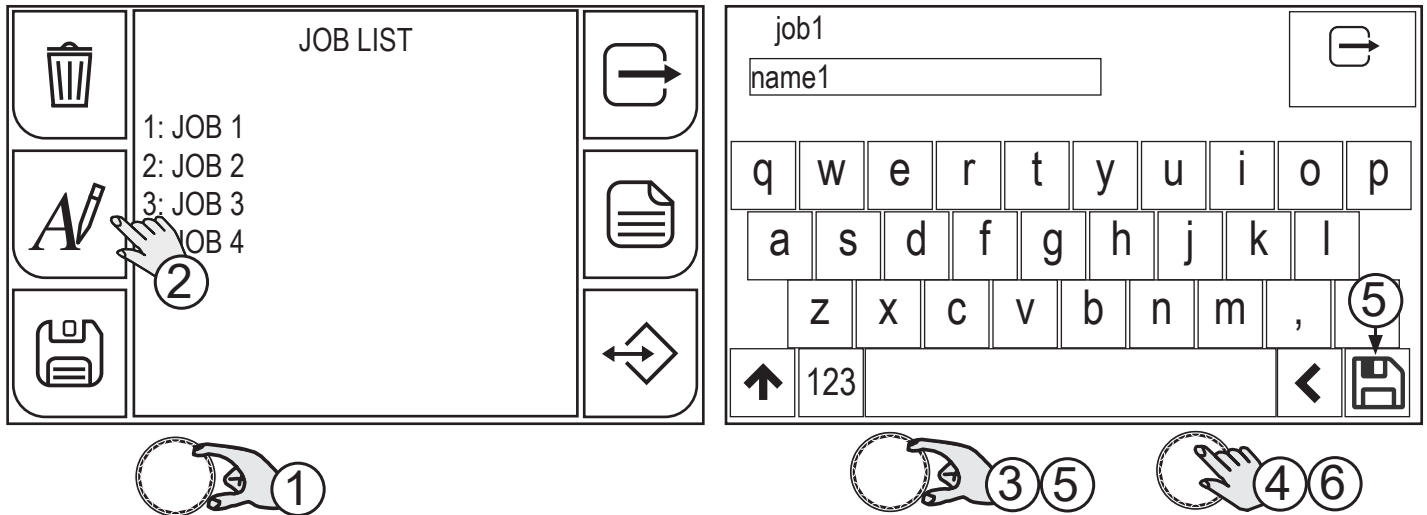

1. Select the JOB to be renamed by using the encoder.
2. Press the (RENAME) key. The keyboard will appear to write the name of the job.

 The touchscreen panel allows the user to set up the functions through the mechanical keys or by touching the icons displayed on the screen.

3. Turn the encoder to select the letter on the keyboard.
4. Press the (ENCODER) key to confirm your selection.
5. Turn the encoder to select the (SAVE) symbol on the keyboard.
6. Press the (ENCODER) key to save and exit.

Press the  key to exit without saving.

ENGLISH

10.3 LOADING A JOB

Enter the JOB screen, which contains the list of stored JOBS.

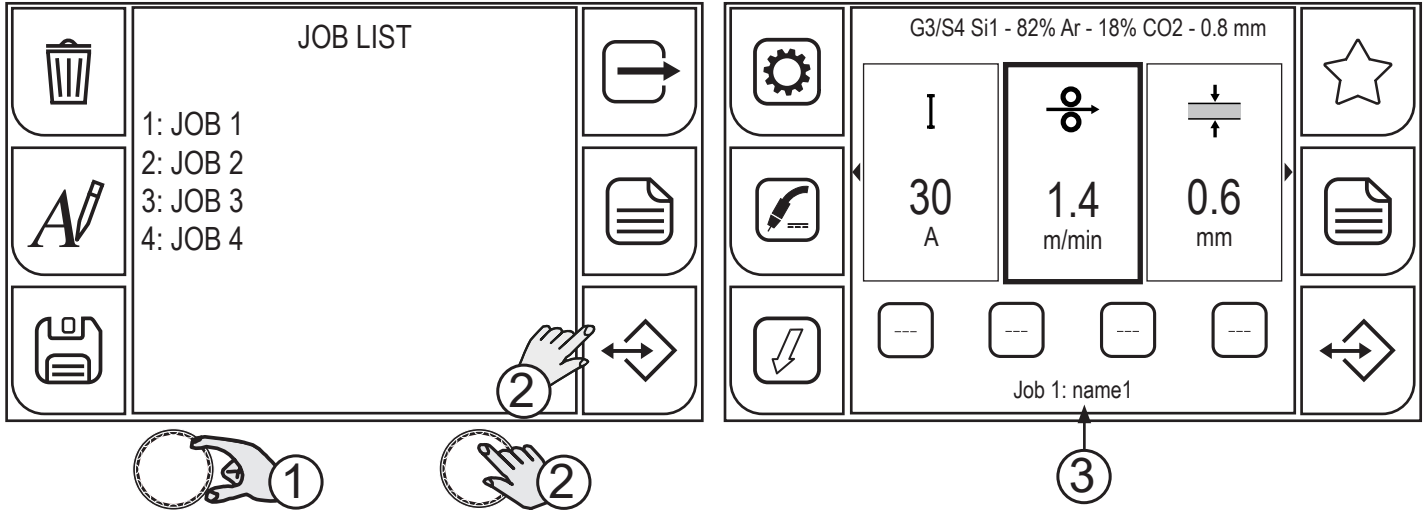

1. Select the JOB to be loaded by using the encoder.
2. Press the (ENCODER) key or the (LOAD) key.
3. The main screen appears with the name of the loaded job.
- 4.

10.4 DELETING A JOB

Enter the JOB screen, which contains the list of stored JOBS.

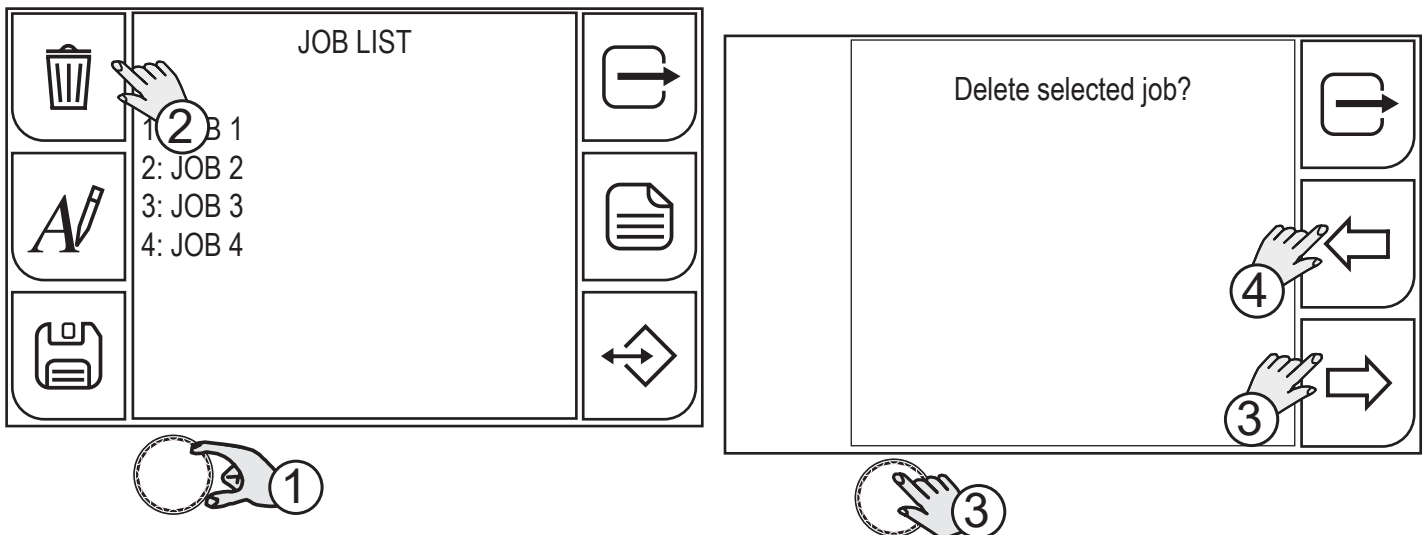

1. Select the JOB to be deleted by using the encoder.
2. Press the (DELETE) key.
3. Press the (ENCODER) key or the (YES) key to confirm,
4. or the (NO) key to return to the previous screen.

10.5 EXPORTING JOBS

Enter the JOB screen.

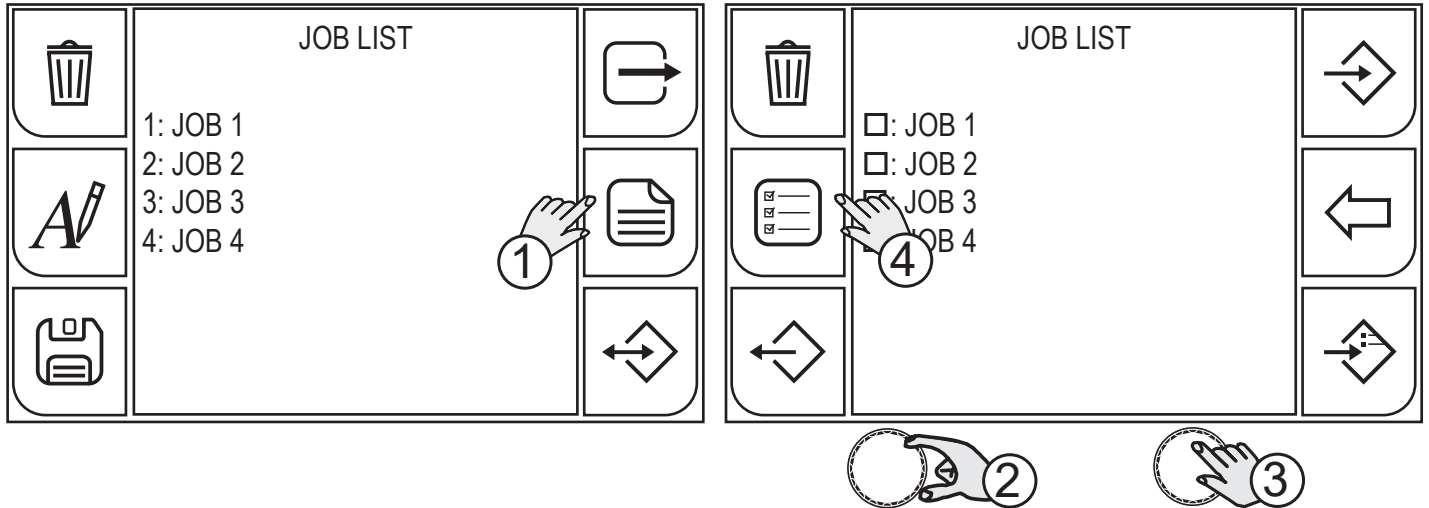

1. Press the (MENU) key.
2. Select the JOB to be exported by using the encoder.
3. Press the (ENCODER) key to confirm your selection.
4. If you wish to select/deselect all the JOBS, press the (SELECT ALL) / (DESELECT ALL) key.

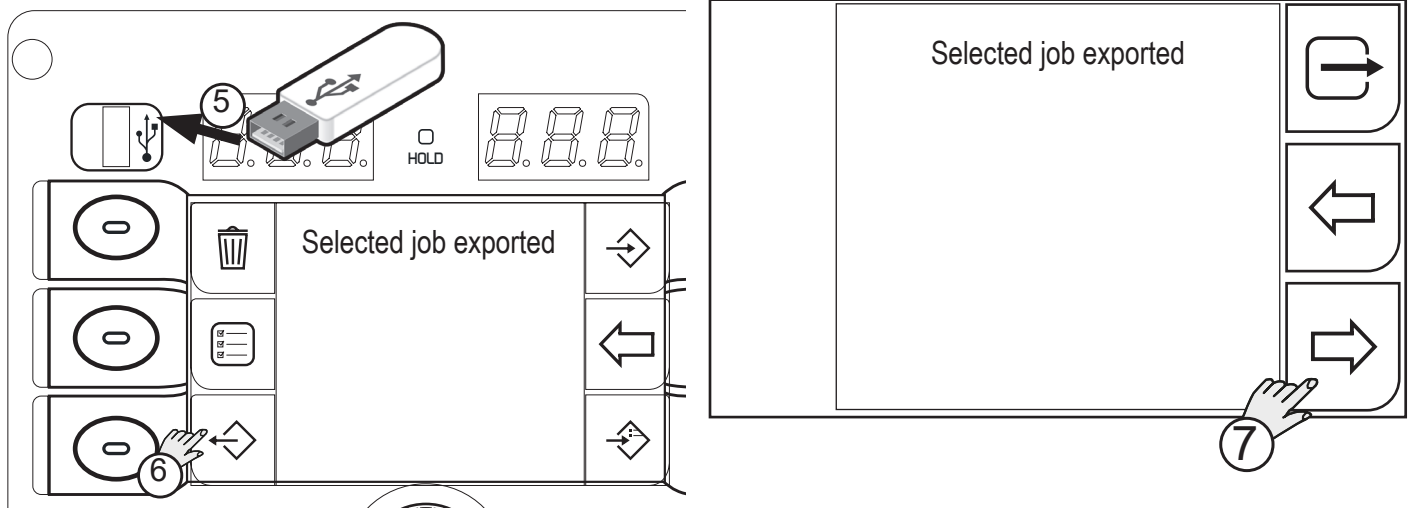

5. Insert the USB memory stick in the port provided.
6. Press the (EXPORT) key to export the files to the USB memory stick. If the exporting operation is successful, the message "Selected jobs exported" will appear.
7. Press the (OK) key

Press the (NO) key to return to the previous screen.

To return to the main screen, press the (EXIT) key.

10.6 IMPORTING JOBS

Enter the JOB screen.

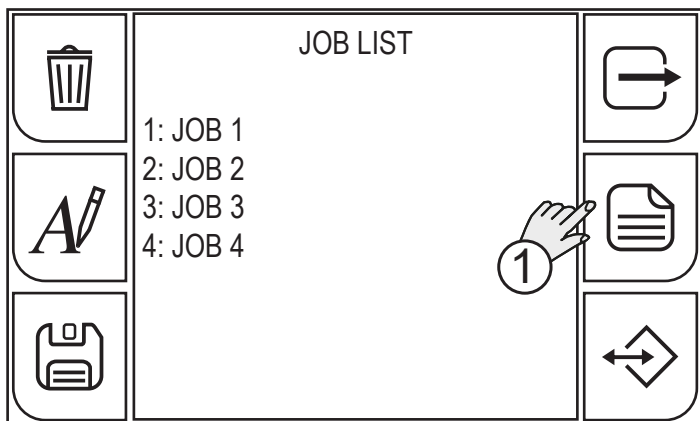

1. Press the (MENU) key.

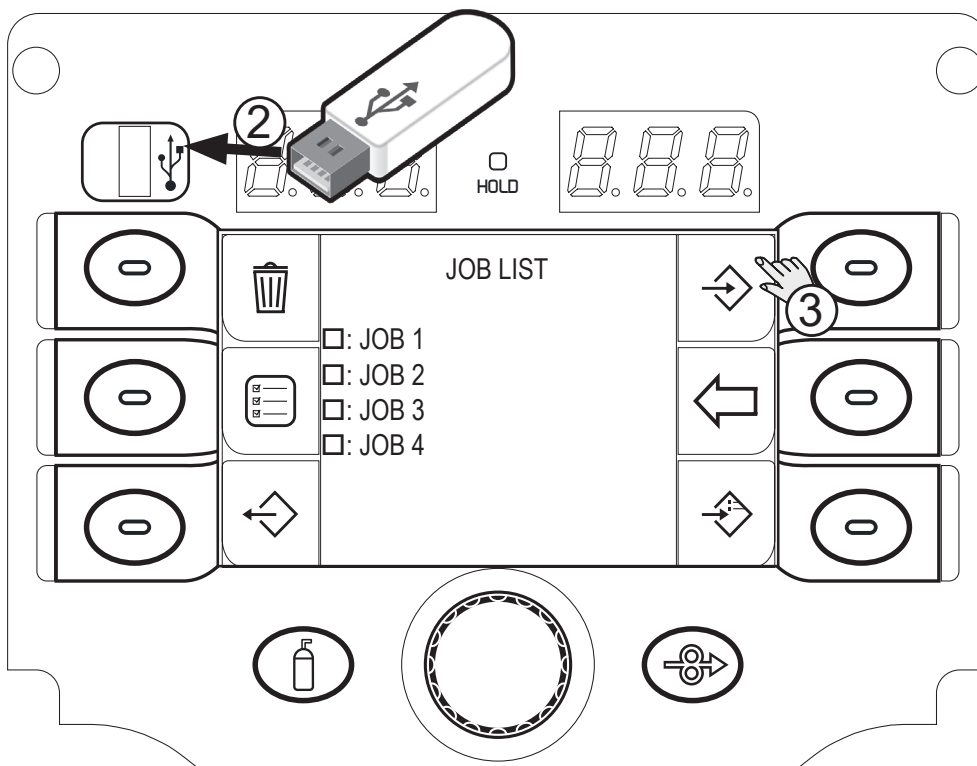

2. Insert the USB memory stick in the port provided.
3. Press the (IMPORT) key to import the files saved onto the USB memory stick.
If the files are stored on the USB memory stick in the same position (number before name) as the files located in the WF-205, the latter will be overwritten by the files saved on the memory stick.

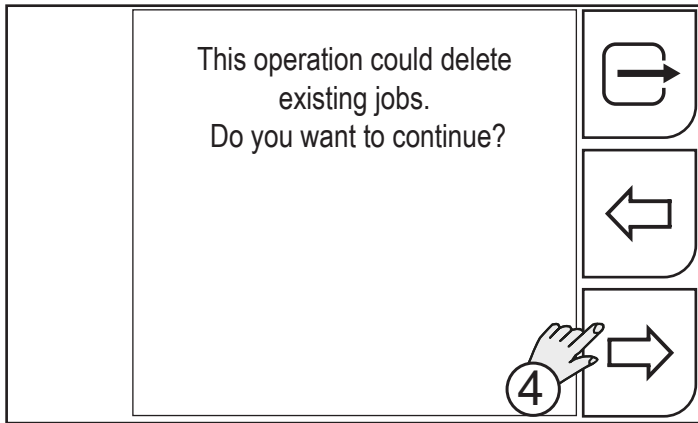

4. Press the (YES) key.

Press the  (NO) key to return to the previous screen.

To return to the main screen, press the  (EXIT) key.

10.7 ADDING JOBS

Enter the JOB screen.

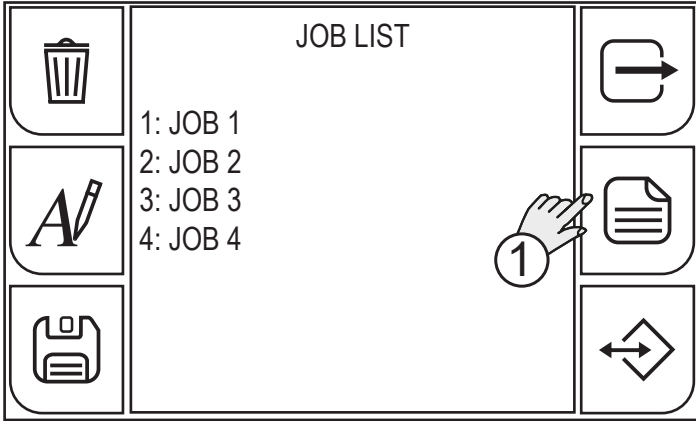

1. Press the (MENU) key.

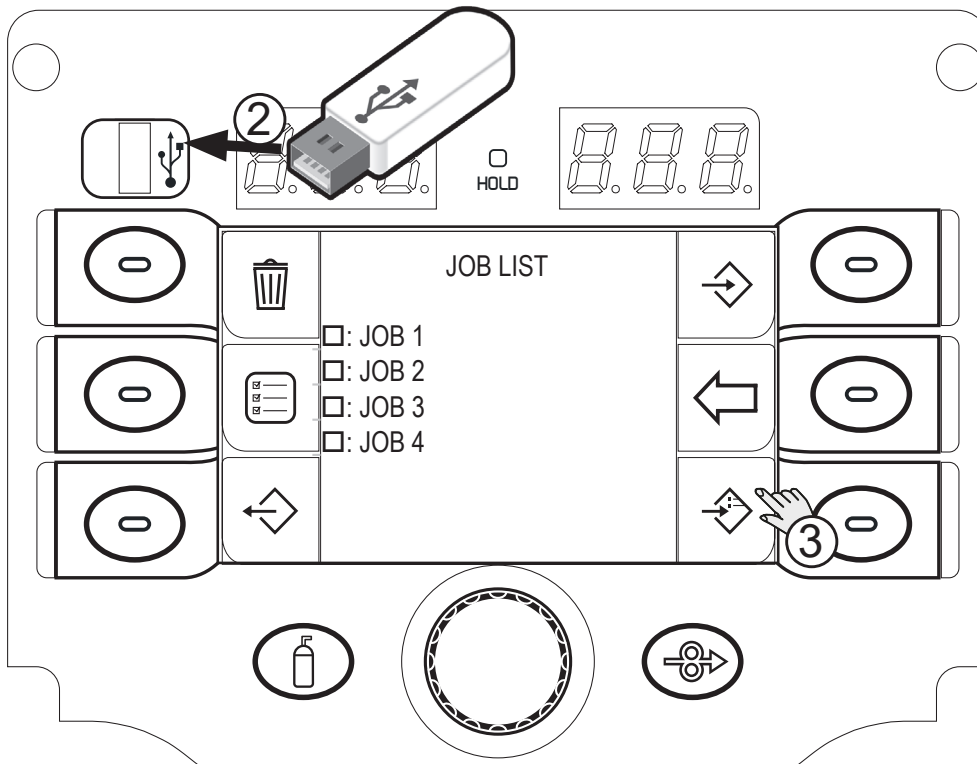

2. Insert the USB memory stick in the port provided.
3. Press the (ADD) key to add to the JOBS located on the WF-205 the files saved on the USB memory stick. The files located on the USB memory stick will be added to the files located on the WF-205, renumbering and adding them at the bottom of the list.

11 SETTING THE FAVOURITE KEY

The (SHORTCUT) keys can be associated to a specific function amongst those available from a preset list.

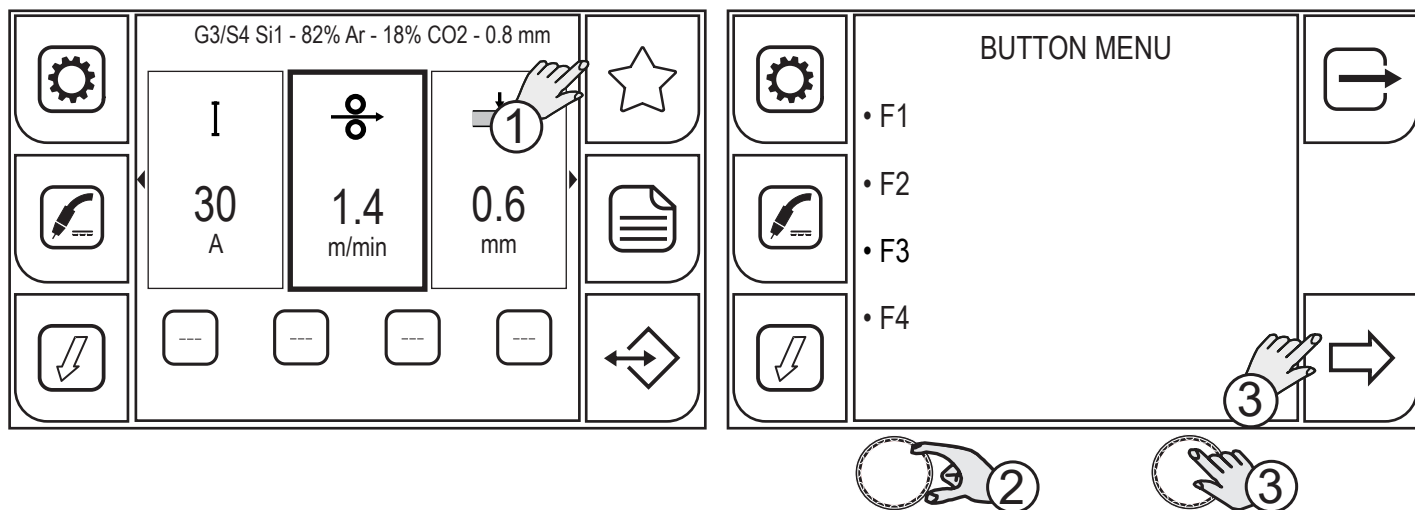

1. Press the (FAVOURITE) key; The BUTTON MENU will be displayed. From the menu screen, the (Fn) key can be selected to associate it to a specific function. Keep the (SHORTCUT) key pressed for 3 seconds to access the functions screen.
2. Turn the encoder to select the desired key.
3. Press the (ENCODER) key again or the (NEXT) key.

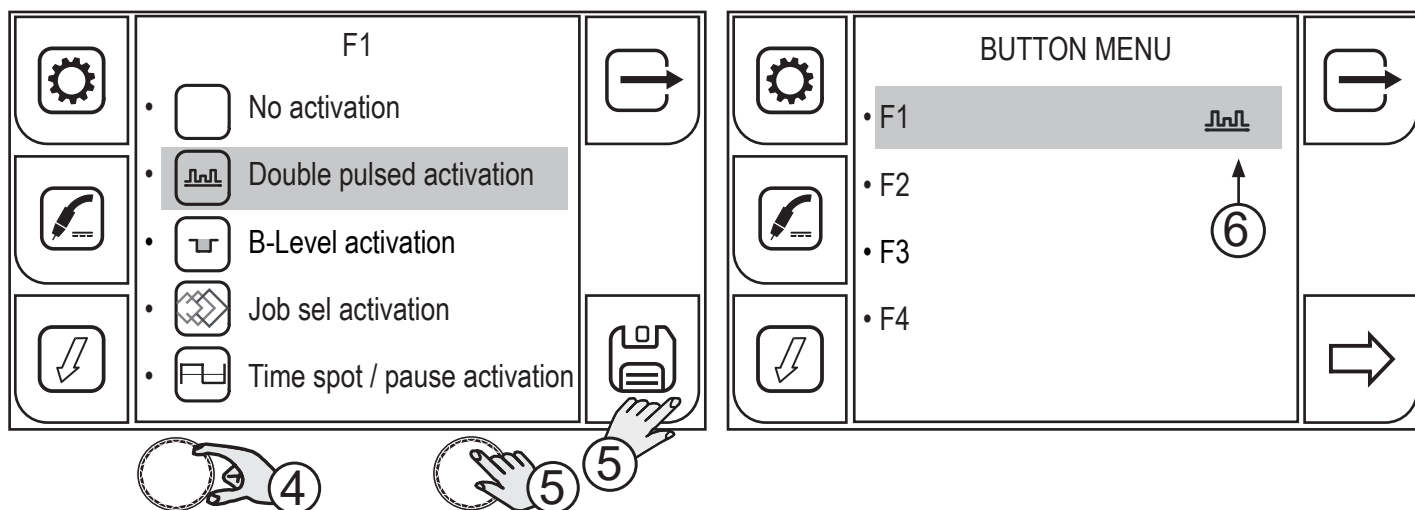

4. Turn the encoder to select the desired function.
 - (No activation, Double pulse activation, B-Level activation, Job sel activation, Time spot / pause activation, K Deep activation, Job load activation).
5. Press the (ENCODER) key again or the (SAVE) key.

To exit the screen, press the key.

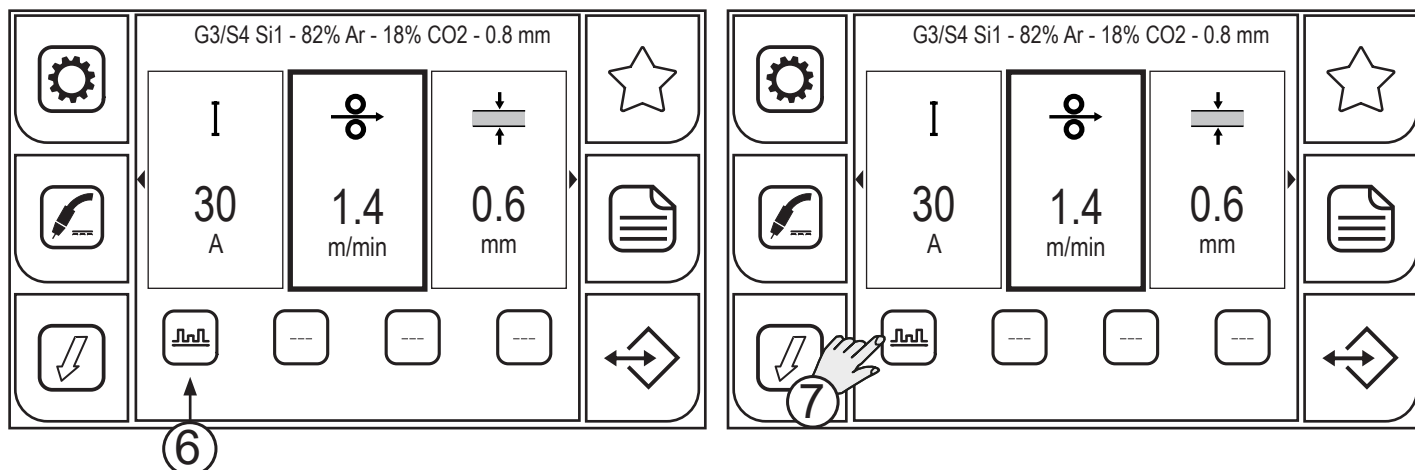

6. After associating the desired function to the SHORTCUT key, the function icon will be displayed both in the BUTTON menu and on the key displayed in the main screen.
7. Press the key with the associated function to enable/disable the function. When the function is enabled, the key will be highlighted in yellow.

12 RESET

The reset procedure is useful in the following cases:

- Too many changes made to the welding parameters so user finds it difficult to restore defaults.
- Unidentified software problems that prevent the current generator from functioning correctly.

12.1 RESET PARAMETERS

The reset procedure involves restoring the parameter values and settings, except the following settings:

- System menu settings.
- Saved JOBs.

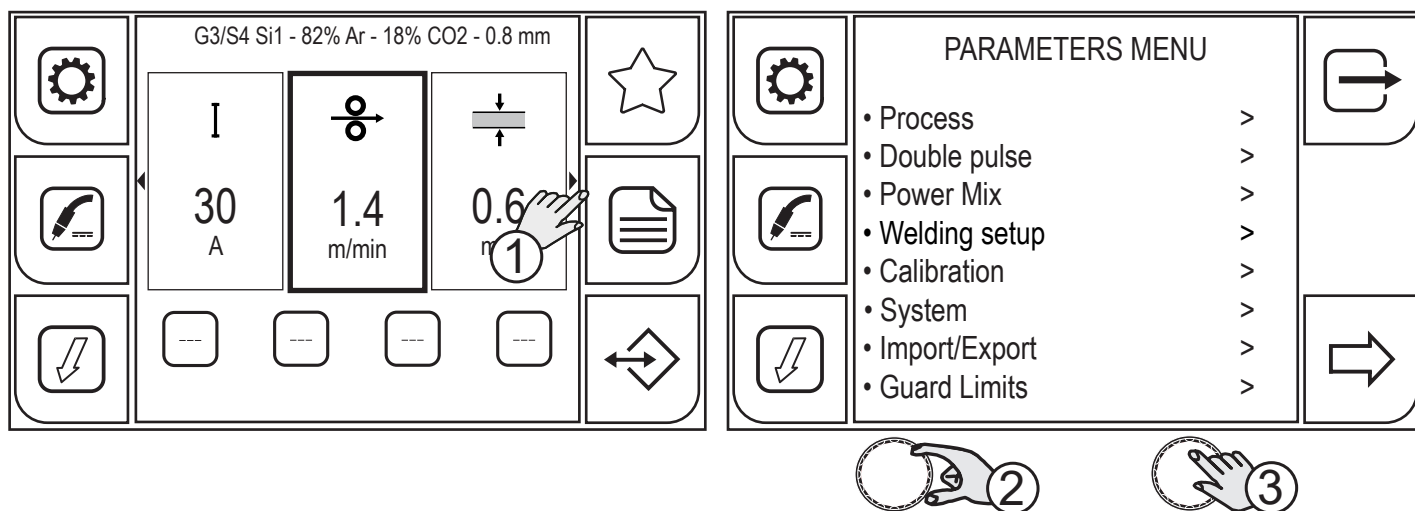

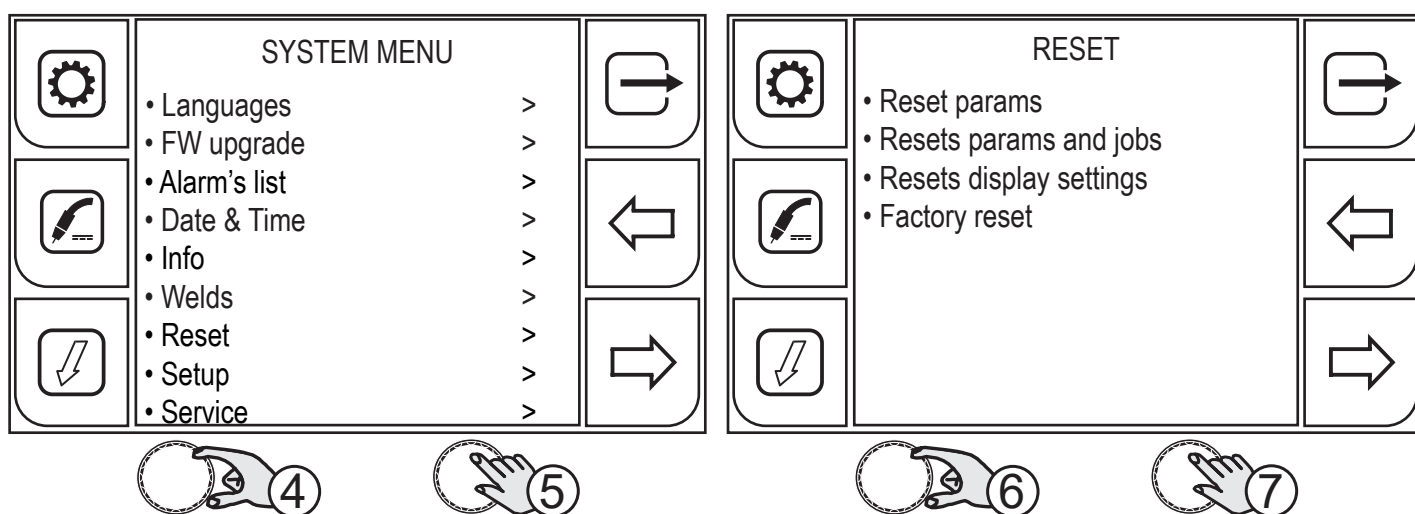

1. Press the (MENU) key.
2. Turn the encoder to select the desired setting. Select the following path: System>
3. Press the (ENCODER) key to confirm.

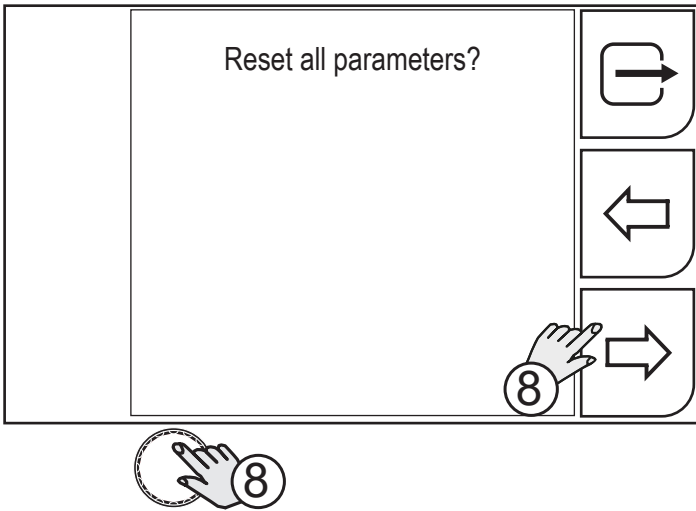

4. Turn the encoder to select the desired setting. Select the following path: Reset>
5. Press the (ENCODER) key to confirm.
6. Turn the encoder to select the desired setting. Select the following path: Reset params
7. Press the (ENCODER) key to confirm.



8. Press the (ENCODER) key or the (YES) key.
Press the  (NO) key to return to the previous screen.
To return to the main screen, press the  (EXIT) key.

12.2 RESET PARAMETERS AND JOBS

The reset procedure involves fully restoring the default settings for values, parameters and memories. All memory locations will be reset and hence all your personal welding settings will be lost!

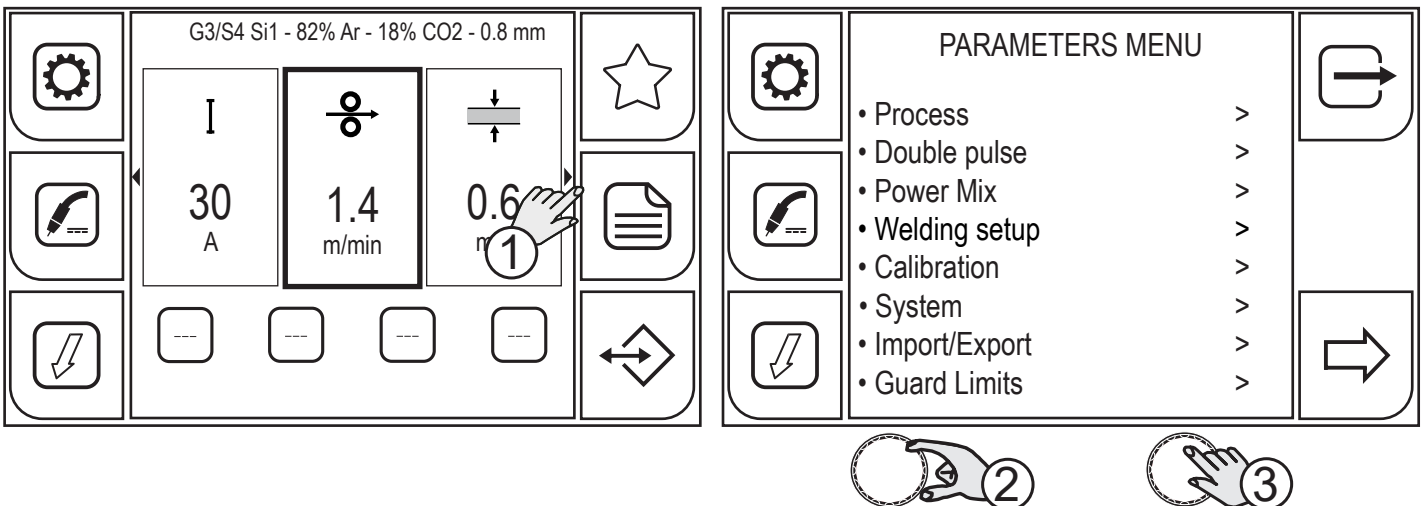

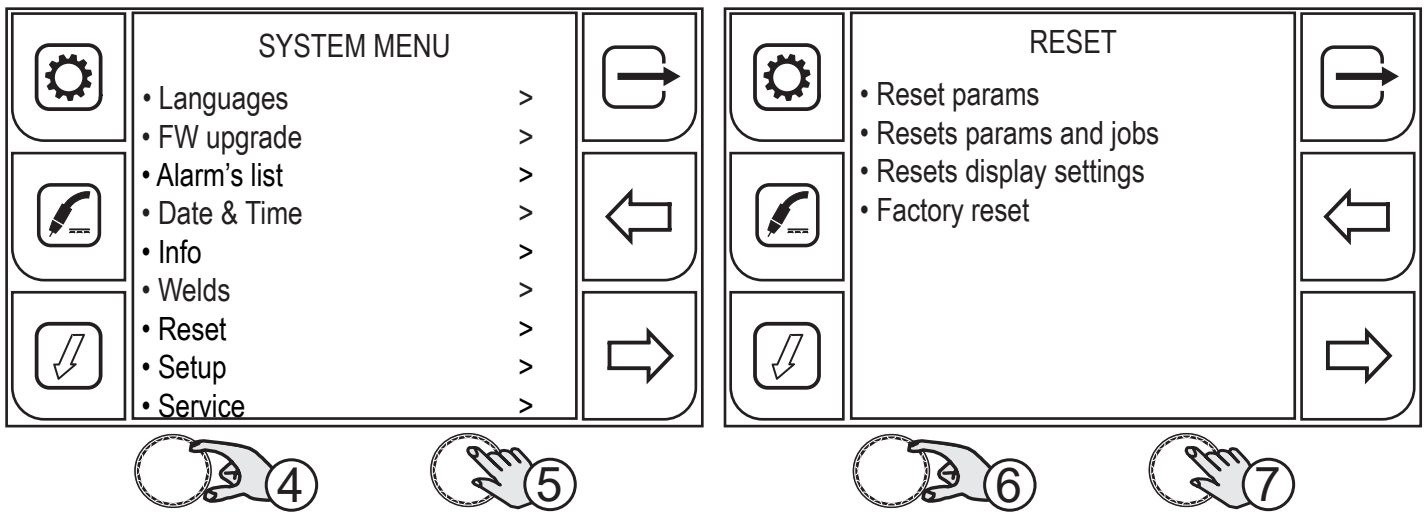

1. Press the (MENU) key.
2. Turn the encoder to select the desired setting. Select the following path: System>
3. Press the (ENCODER) key to confirm.

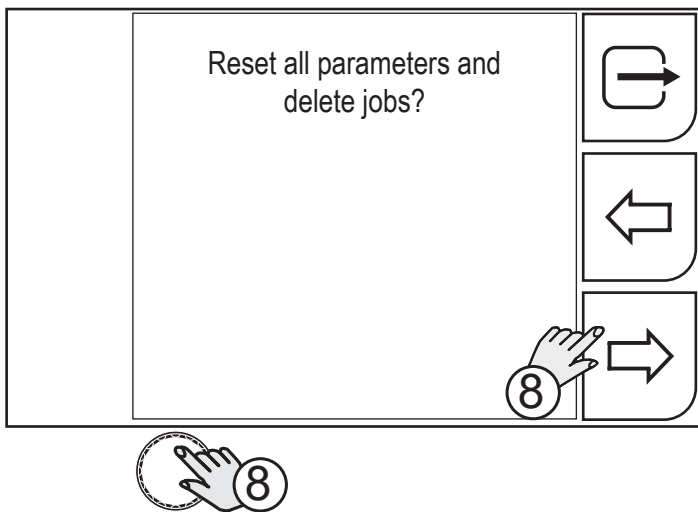

4. Turn the encoder to select the desired setting. Select the following path: Reset>
5. Press the (ENCODER) key to confirm.
6. Turn the encoder to select the desired setting. Select the following path: Resets params and jobs.
7. Press the (ENCODER) key to confirm.



8. Press the (ENCODER) key or the (YES) key.
Press the  (NO) key to return to the previous screen.
To return to the main screen, press the  (EXIT) key.

12.3 RESET DISPLAY SETTINGS

The reset display settings procedure restores the display preset settings. The default language (English) is restored; the shortcut keys are reset; the default parameter display settings are restored.

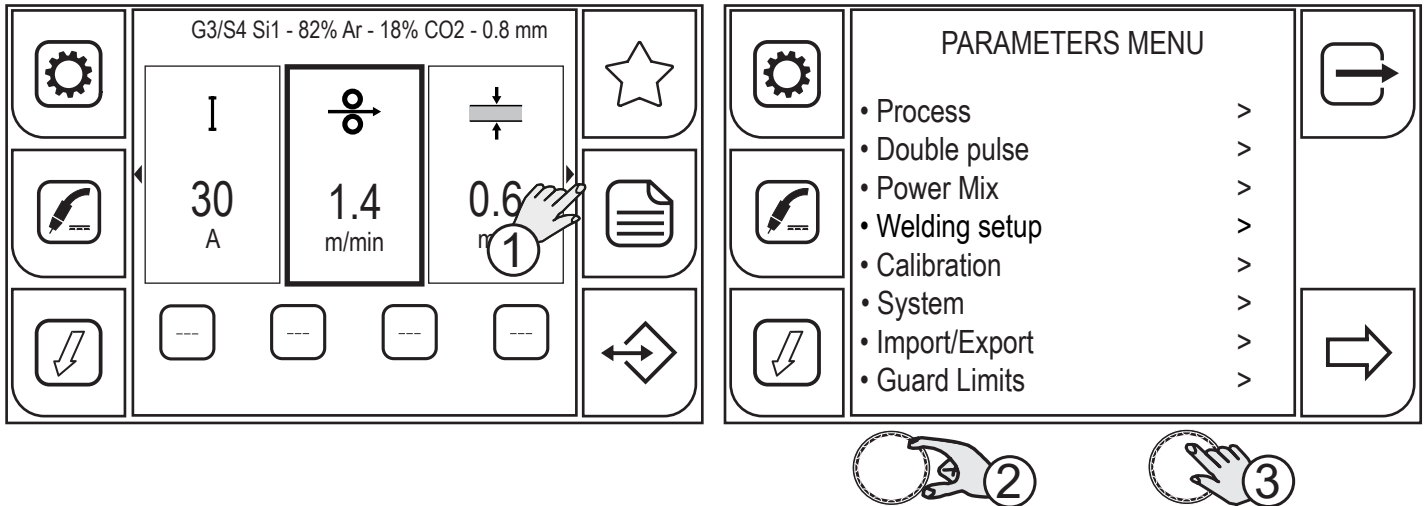

1. Press the (MENU) key.
2. Turn the encoder to select the desired setting. Select the following path: System>
3. Press the (ENCODER) key to confirm.

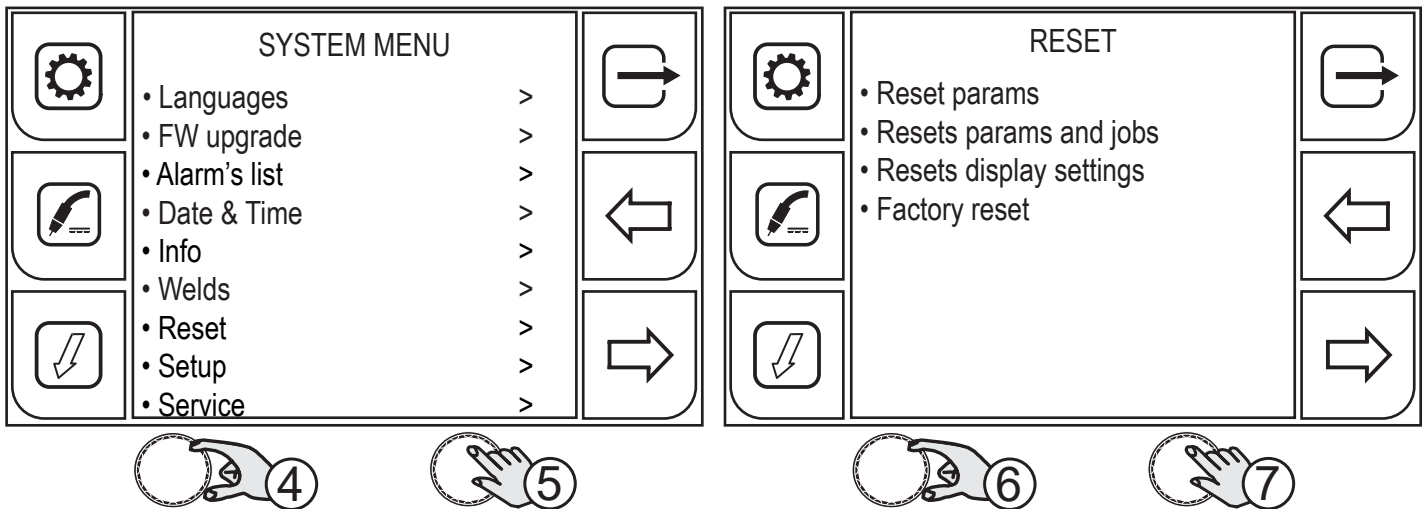

4. Turn the encoder to select the desired setting. Select the following path: Reset>
5. Press the (ENCODER) key to confirm.
6. Turn the encoder to select the desired setting. Select the following path: Resets display settings.
7. Press the (ENCODER) key to confirm.

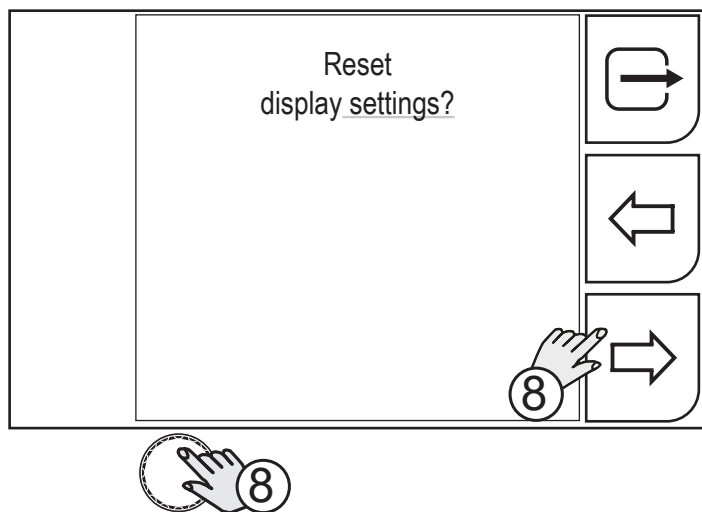

- Press the (ENCODER) key or the (YES) key.
Press the ← (NO) key to return to the previous screen.
To return to the main screen, press the → (EXIT) key.

12.4 FACTORY SETTINGS

The factory settings reset procedure involves fully restoring the default settings for values, parameters and memories.

All memory locations will be reset and hence all your personal welding settings will be lost!

Date and time settings remain saved, only.

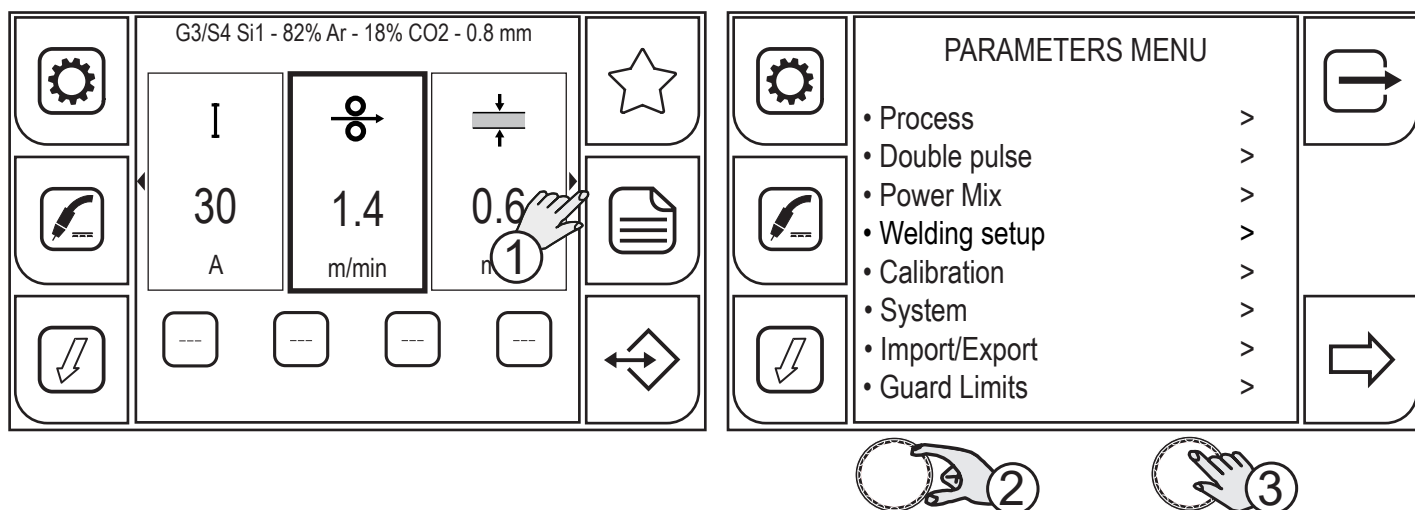

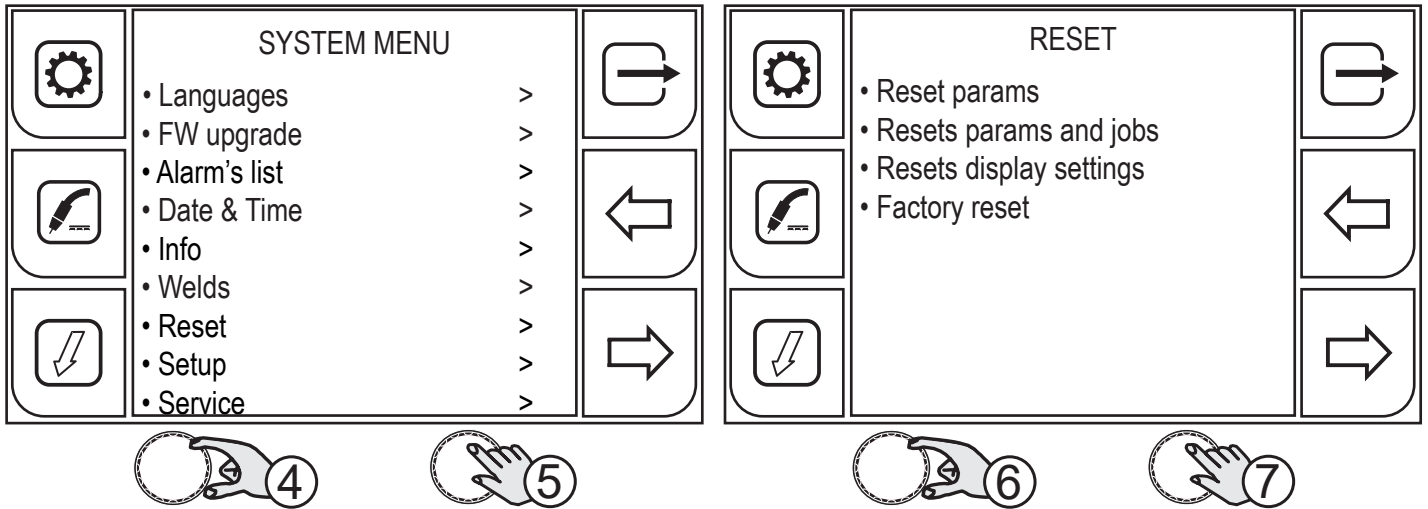

- Press the (MENU) key.
- Turn the encoder to select the desired setting. Select the following path: System>
- Press the (ENCODER) key to confirm.

ENGLISH

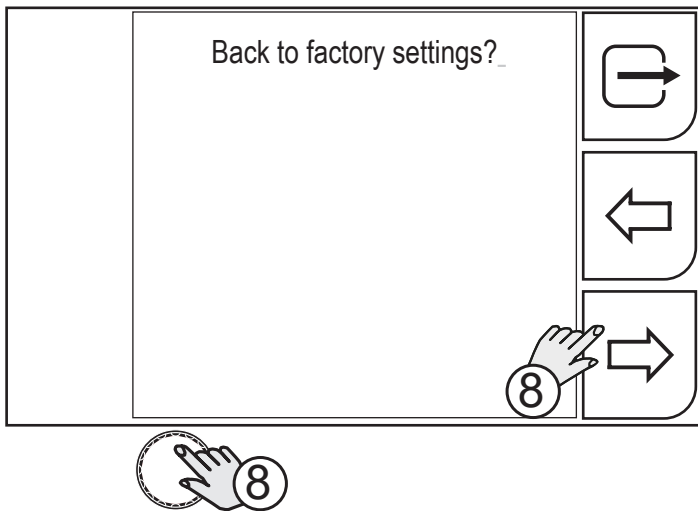

4. Turn the encoder to select the desired setting. Select the following path: Reset>
5. Press the (ENCODER) key to confirm.
6. Turn the encoder to select the desired setting. Select the following path: Factory reset.
7. Press the (ENCODER) key to confirm.



8. Press the (ENCODER) key or the (YES) key.
Press the  (NO) key to return to the previous screen.
To return to the main screen, press the  (EXIT) key.

13 ALARM MANAGEMENT

This function is available when the welding mode is disabled.

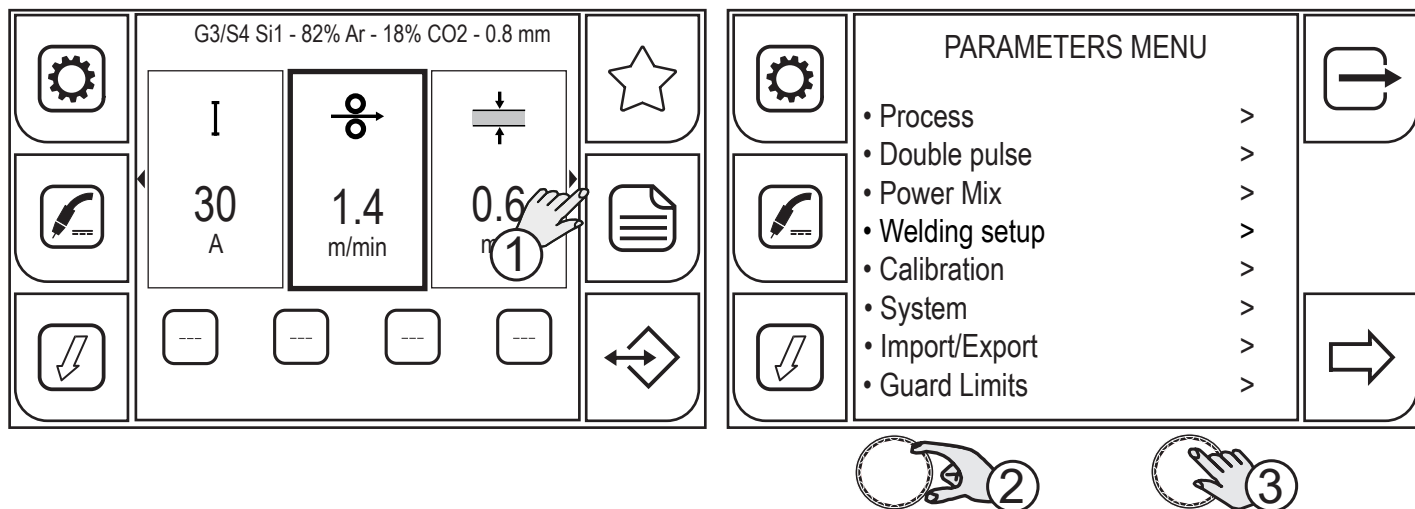

1. Press the (MENU) key.
2. Turn the encoder to select the desired setting. Select the following path: System>
3. Press the (ENCODER) key or the (NEXT) key.

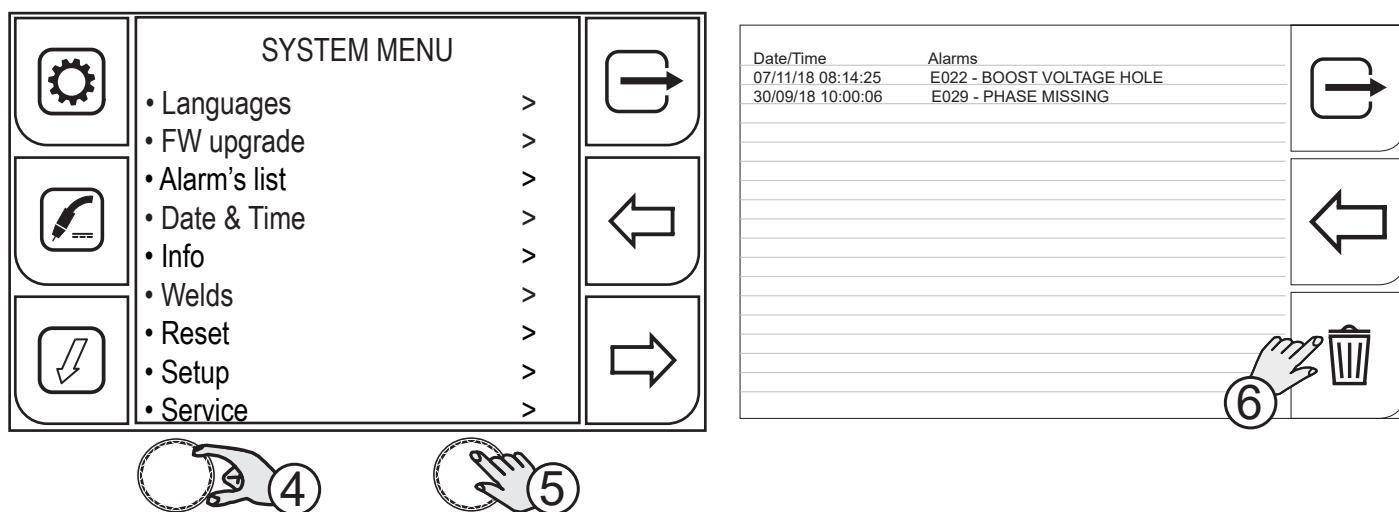

4. Turn the encoder to select the desired setting. Select the following path: Alarm's list>
5. Press the (ENCODER) key or the (NEXT) key. The list of alarms stored is displayed.
6. Press the (RESET ALARMS) key to delete the list.

When an alarm condition occurs, all functions are disabled, with the exception of:

- the cooling fan
- the cooling unit (if enabled)
-

CODE	MEANING	SOLUTION
E02	NTC DISCONNECTED This indicates that the information between the NTC and the monitoring system is no longer being sent.	Qualified technical staff must be called out to carry out the repairs/maintenance operations.
E04	VOUT DISCONNECTED This indicates that there is a short-circuit between the welding sockets (+) and (-).	<ul style="list-style-type: none"> - Make sure that the welding torch is not touching the earthed workpiece to be welded. - Make sure that, when the generator is switched on, there is no short-circuit between the sockets (the voltage must be higher than/equal to the U_r). - If the problem persists, qualified technical staff must be called out to carry out the repairs/maintenance operations.
E05	WELD TORCH TRIGGER PRESSED This indicates that, when the generator is switched on, a short-circuit has been detected on the torch trigger input. When the problem is sorted out, the current generator will be automatically reset.	<ul style="list-style-type: none"> - Make sure that the torch trigger is not pressed, stuck or short-circuited. - Make sure that the torch and the torch connector are in good conditions.
E22	BOOST VOLTAGE HOLE This alarm indicates that a sudden power outage in the power mains has occurred.	<ul style="list-style-type: none"> - If the problem occurs frequently, check the stability of the mains power. <p>When the problem is solved, the power generator will be automatically reset.</p>
E23	BOOST CURRENT LIMIT ALARM Mains power boost overcurrent	Qualified technical staff must be called out to carry out the repairs/maintenance operations.
E25	BOOST CURRENT NOT CALIBRATED ALARM Current phases input is unbalanced	Qualified technical staff must be called out to carry out the repairs/maintenance operations.
E26	ALARM GROUND CURRENT Current is re-circulated on the ground circuit	Qualified technical staff must be called out to carry out the repairs/maintenance operations.
E27	ALARM UNDERVOLTAGE Low power supply voltage	<ul style="list-style-type: none"> - Make sure the mains power does not go below the minimum permitted values.
E28	ALARM OVERVOLTAGE High power supply voltage	<ul style="list-style-type: none"> - Make sure the mains power does not exceed the maximum permitted values.
E29	ALARM PHASE MISSING A phase is missing	<ul style="list-style-type: none"> - Make sure that all the three phases reach the equipment from the power mains. - Make sure that the line fuses on the power supply panel are intact. - If the problem persists, qualified technical staff must be called out to carry out the repairs/maintenance operations.

CODE	MEANING	SOLUTION
E30	ALARM OVERCURRENT The main current threshold has been exceeded	<ul style="list-style-type: none"> - The welding currents are close to the maximum threshold: reduce the welding parameter values. - If the problem persists, qualified technical staff must be called out to carry out the repairs/maintenance operations.
E31	INVERTER THERMAL ALARM Indicates that the welding power generator thermal cut-out switch has tripped.	<ul style="list-style-type: none"> - Leave the equipment switched on to ensure a faster cooling of the overheated components. When the problem is solved, the power generator will be automatically reset. - Make sure that the fans are working correctly. - Make sure that the power required by the current welding process is lower than the maximum specified power. - Make sure that the operating condition complies with the power generator nameplate. - Make sure that the air flowing around the power generator is adequate.
E32	SECONDARY THERMAL ALARM Indicates that the welding power generator thermal cut-out switch has tripped.	
E50	WARNING COOLING SYSTEM Indicates insufficient pressure in the torch cooling circuit.	<ul style="list-style-type: none"> - Make sure that the cooling unit is correctly connected. - Make sure that the O/I switch is set to "I" and that its led goes on when the pump is enabled. - Make sure that there is enough coolant in the cooling unit. - Make sure that the pump delivers the coolant (external bypass present) - Make sure that the cooling circuit is in good conditions, specially the torch hoses and the internal connections of the cooling unit. - Make sure that the fans are working correctly. - If the problem persists, qualified technical staff must be called out to carry out the repairs/maintenance operations.
E51	COOLING UNIT ALARM The coolant temperature exceeds the threshold	
E52	COOLING UNIT NTC ALARM NTC on the CU disconnected	Qualified technical staff must be called out to carry out the repairs/maintenance operations.
E60	MOTOR CURRENT ALARM WF High motor input current	<ul style="list-style-type: none"> - Make sure that the motor is not mechanically blocked by an object. - If the problem persists, qualified technical staff must be called out to carry out the repairs/maintenance operations.

CODE	MEANING	SOLUTION
E70	NO GAS ALARM Gas flow not detected	<ul style="list-style-type: none"> - Check the gas flow rate in the system connected to the device. - If the problem persists, qualified technical staff must be called out to carry out the repairs/maintenance operations.
E81	ALARM HIGH CURRENT LIMIT EXCEEDED	<ul style="list-style-type: none"> - Make sure that the guard limit parameter is correct according to the preset welding parameter. - Make sure that there are no welding problems associated with the consumable, gas used, welding position, earth, torch, wire feeder, special functions enabled (K-Deep).
E82	ALARM LOW CURRENT LIMIT EXCEEDED	
E83	ALARM HIGH VOLTAGE LIMIT EXCEEDED	<ul style="list-style-type: none"> - Make sure that the guard limit parameter is correct according to the preset welding parameter. - Make sure that there are no welding problems associated with the consumable, gas used, welding position, ground terminal, torch, wire feeder, special functions enabled.
E84	ALARM LOW VOLTAGE LIMIT EXCEEDED	
E85	ALARM HIGH WIRE SPEED LIMIT EXCEEDED	<ul style="list-style-type: none"> - Make sure that the guard limit parameter is correct according to the preset welding parameter. - Make sure that there are no welding problems associated with the consumable, gas used, welding position, ground terminal, torch, wire feeder, special functions enabled (K-Deep).
E86	ALARM LOW WIRE SPEED LIMIT EXCEEDED	
E87	ALARM HIGH GAS FLOW LIMIT EXCEEDED	<ul style="list-style-type: none"> - Check the gas flow rate in the system connected to the device. - If the problem persists, qualified technical staff must be called out to carry out the repairs/maintenance operations.
E88	ALARM LOW GAS FLOW LIMIT EXCEEDED	<ul style="list-style-type: none"> - Check the gas flow rate in the system connected to the device. - If the problem persists, qualified technical staff must be called out to carry out the repairs/maintenance operations.

CODE	MEANING	SOLUTION
E89	MOTOR HIGH CURRENT LIMIT EXCEEDED ALARM	<ul style="list-style-type: none"> - Make sure that the guard limit parameter is correct according to the preset welding parameter. - Make sure that there are no welding problems associated with the consumable, the welding position, the torch, the wire feeder. - If the problem persists, qualified technical staff must be called out to carry out the repairs/maintenance operations.
W81	WARNING HIGH CURRENT LIMIT EXCEEDED	<ul style="list-style-type: none"> - Make sure that the guard limit parameter is correct according to the preset welding parameter. - Make sure that there are no welding problems associated with the consumable, gas used, welding position, earth, torch, wire feeder, special functions enabled (K-Deep).
W82	WARNING LOW CURRENT LIMIT EXCEEDED	
W83	WARNING HIGH VOLTAGE LIMIT EXCEEDED	<ul style="list-style-type: none"> - Make sure that the guard limit parameter is correct according to the preset welding parameter. - Make sure that there are no welding problems associated with the consumable, gas used, welding position, ground terminal, torch, wire feeder, special functions enabled.
W84	WARNING LOW VOLTAGE LIMIT EXCEEDED	
W85	WARNING HIGH WIRE SPEED LIMIT EXCEEDED	<ul style="list-style-type: none"> - Make sure that the guard limit parameter is correct according to the preset welding parameter. - Make sure that there are no welding problems associated with the consumable, gas used, welding position, ground terminal, torch, wire feeder, special functions enabled (K-Deep).
W86	WARNING LOW WIRE SPEED LIMIT EXCEEDED	
W87	WARNING HIGH GAS FLOW LIMIT EXCEEDED	<ul style="list-style-type: none"> - Check the gas flow rate in the system connected to the device. - If the problem persists, qualified technical staff must be called out to carry out the repairs/maintenance operations.
W88	WARNING LOW GAS FLOW LIMIT EXCEEDED	

CODE	MEANING	SOLUTION
W89	MOTOR HIGH CURRENT LIMIT EXCEEDED WARNING	<ul style="list-style-type: none">- Make sure that the guard limit parameter is correct according to the preset welding parameter.- Make sure that there are no welding problems associated with the consumable, the welding position, the torch, the wire feeder.- If the problem persists, qualified technical staff must be called out to carry out the repairs/maintenance operations.
E99	GENERAL ALARM This indicates that the generator has not been identified.	<p>Check the connections between the generator and the remote devices (wire feeders, remote controls, other devices).</p> <ul style="list-style-type: none">- If the problem persists, qualified technical staff must be called out to carry out the repairs/maintenance operations.

14 SYSTEM INFO

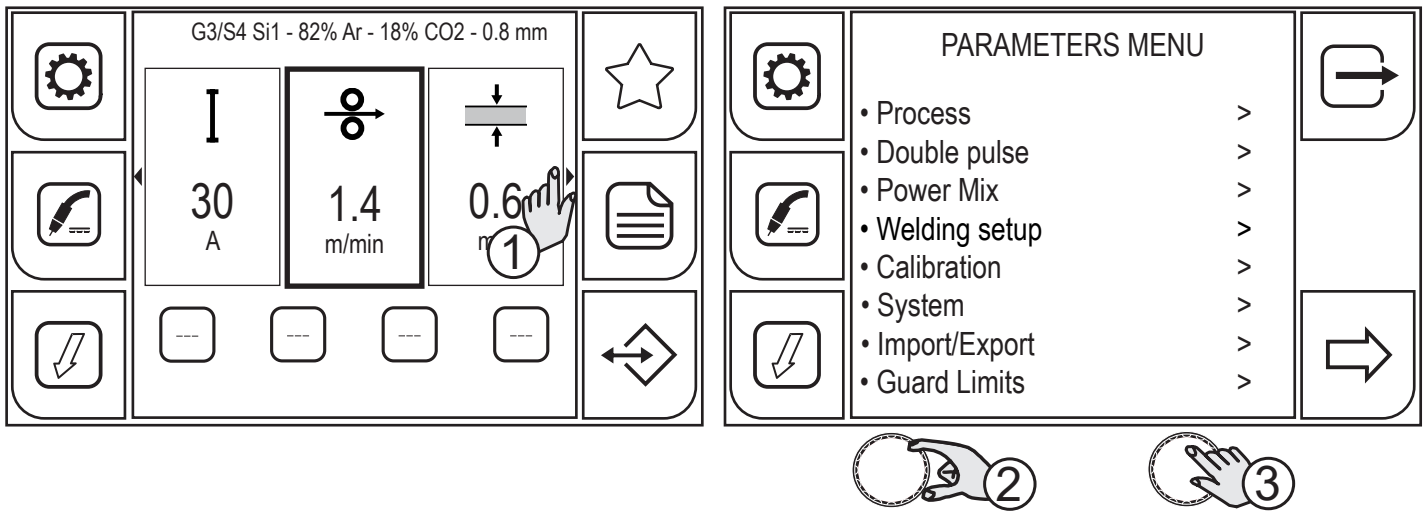

1. Press the (MENU) key.
2. Turn the encoder to select the desired setting. Select the following path: System>
3. Press the (ENCODER) key or the (NEXT) key to confirm.

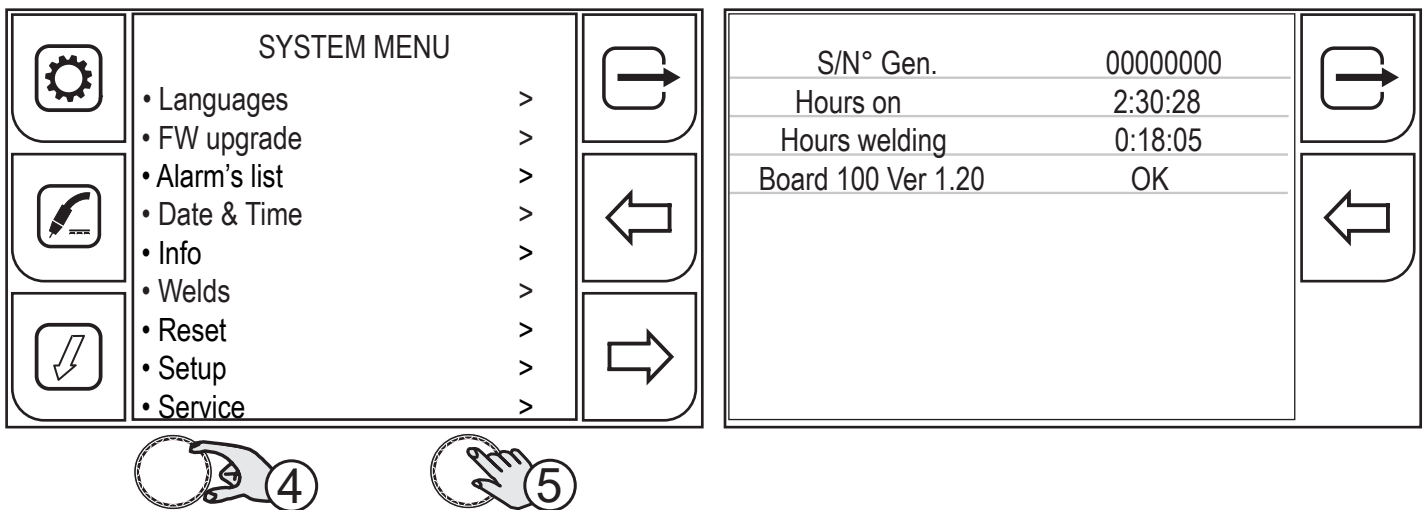

4. Turn the encoder to select the desired setting. Select the following path: Info>
5. Press the (ENCODER) key or the (NEXT) key to confirm.

The screen shows:

- the serial number of the generator
- the number of hours of operation of the machine
- the number of hours with the arc on











After 10 seconds, the screen will show:

- the list of boards with microprocessor and their firmware version.

6. Press the (DATI) key.

This key allows the screen showing real time data to be displayed.

ENGLISH

I A 140	U V 20.0	 m/min 10.4	 l/min 1.0	 
 1	 s 45	 IP kW 1.25	 IE kJ 1.09	
 A 2.3	 C° 20	 C° 20		

I
A
140

Instantaneous value of welding current.

U
V
20.0

Instantaneous value of welding voltage.

m/min
10.4

Instantaneous value of wire speed.

l/min
1.0

Gas flow value in litres/minute (only if the sensor is fitted).

1

Sequential number of the weld bead from the time the generator is switched on (it starts from 1 each time it is switched on).

s
45

Welding duration of single weld bead,

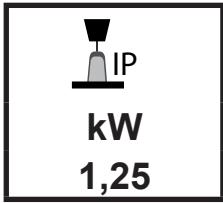

Instantaneous power of welding arc in KW.
INSTANTANEOUS POWER: Average value of the instantaneous power, calculated by multiplying VOLTAGE by CURRENT, sampled every 100 microseconds.

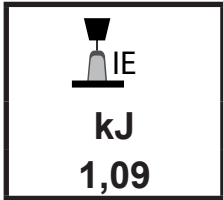

Welding arc energy in KJ.
INSTANTANEOUS ENERGY: Average value of the instantaneous power, calculate by multiplying VOLTAGE by CURRENT in the TIME UNIT sampled every 100 microseconds.

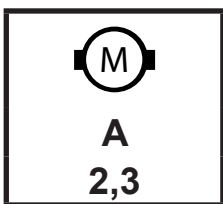

Value of the wire feeder motor current.
It measures the wire feeder motor input current during the welding operation. Excessive values indicate problems with the wire feeder (wire jammed, dirty sheath, worn or obstructed current supply pipe etc.)

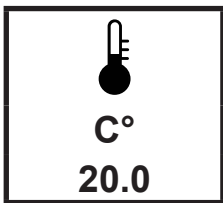

Temperature of the power heat sink in the generator

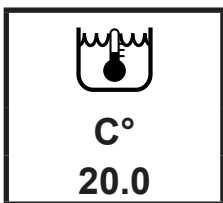

Cooling unit water temperature.

Press the  (PREV) key to return to the previous screen.

To return to the main screen, press the  (EXIT) key.

15 WELDING LOG

This display shows the welding data of the last 500 welding operations carried out. The data can be exported in the .CSV file format onto a USB pen drive.

DISPLAYING THE WELDING LOG

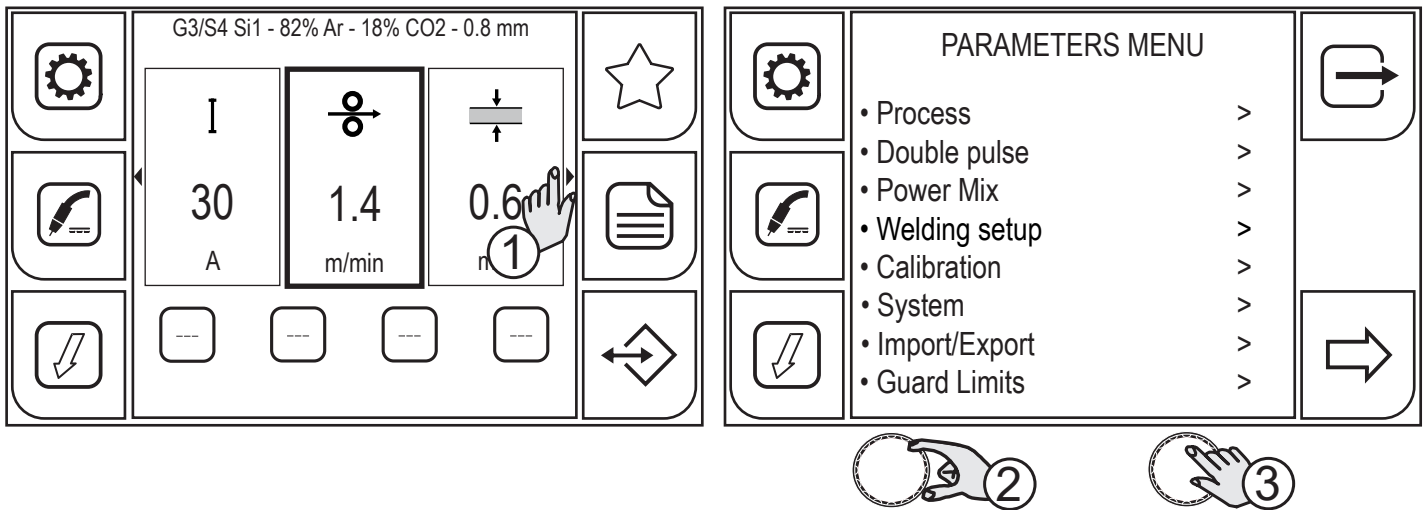

1. Press the (MENU) key.
2. Turn the encoder to select the desired setting. Select the following path: System>
3. Press the (ENCODER) key or the (NEXT) key to confirm.

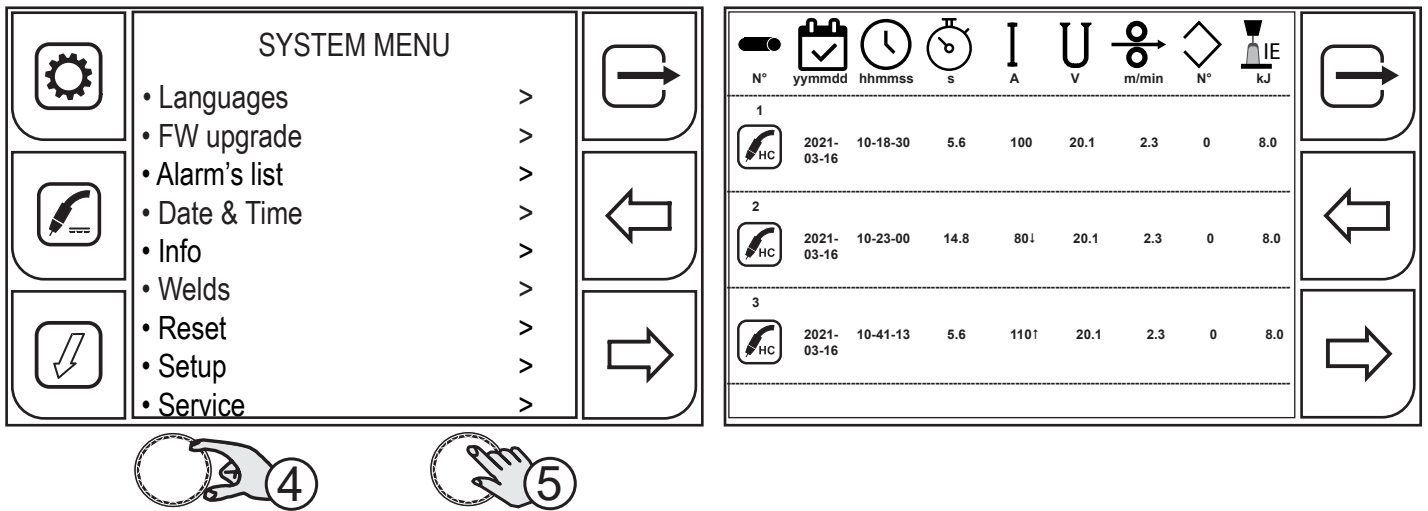

4. Turn the encoder to select the desired setting. Select the following path: Welds>
5. Press the (ENCODER) key or the (NEXT) key to confirm.

The screen shows:

- sequential number of the weld bead from the time the generator is switched on (it starts from 1 each time it is switched on).
- date (day/month/year)
- welding start-up time (time/minutes/seconds)
- welding duration in seconds (single bead)
- average welding current (bead made)
- average welding voltage (bead made)

- average wire speed (only changes if with k-deep)
- job number (if loaded)
- instantaneous energy of welding arc in kJ

If the GUARD LIMITS are enabled, when an alarm/warning condition occurs, the box associated with the monitored parameter will change colour:

- set alarm limit value exceeded (red box + symbol ↓ because the lower limit has been reached or symbol ↑ because the upper limit has been reached)
- set warning limit value exceeded (red box + symbol ↓ because the lower limit has been reached or symbol ↑ because the upper limit has been reached)

EXPORTING THE WELDING LOG

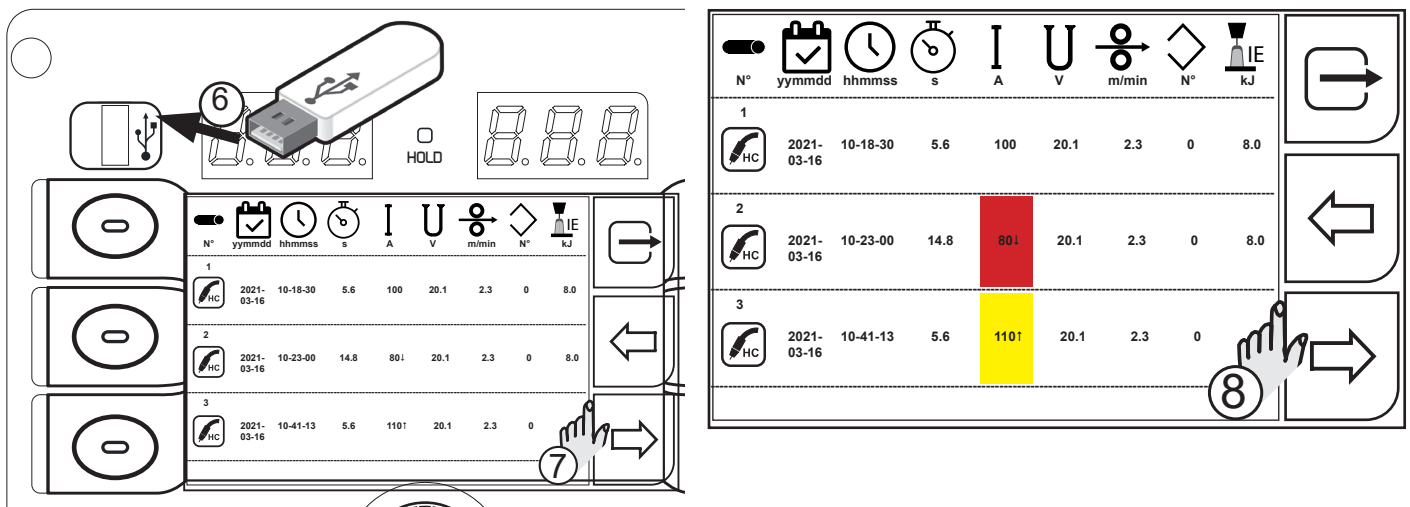

6. Insert the USB memory stick in the port provided.
7. Press the (EXPORT) key.
8. Press the (csv) key.

The data is saved in the CSV format, which can be imported with Excel, for example.



WELD THE WORLD

ENGLISH

	A	B	C	D	E	F	G	H	I	J	K	L	M
1	Type : weldlogs												
2	Date : 2021/04/01 12:49:43												
3	Machine : 257												
4	NumSer : 180027												
5	Seam	Date	Start	Arc time	Current	Voltage	Speed	Power	Energy	Gas	Job	Alarm	
6				s	A	V	m/min	W	kJ	l/min			
7	6	16/03/2021	10:01:49	5,6	100	20,1	2,3	1435	8	0	0	0	
8	5	16/03/2021	10:00:40	10,2	104	16,2	2,3	1499	15,3	0	0	0	
9	4	16/03/2021	09:57:49	5,6	110	15,2	2,4	895	5	0	0	0	
10	3	16/03/2021	09:52:22	3,4	133	15,8	2,3	887	3	0	0	0	
11	2	16/03/2021	09:27:07	6,8	116	17	2,3	1627	11,1	0	0	0	
12	1	16/03/2021	09:25:56	22,8	114	15,7	2,3	1616	36,8	0	0	0	
13	3	15/03/2021	14:44:55	1,6	110	21,1	2,2	1430	2,3	0	0	0	
14	2	15/03/2021	14:43:58	1,4	114	18,1	2,1	1560	2,2	0	0	0	
15	1	15/03/2021	14:43:01	4,2	113	16,4	2,2	1571	6,6	0	0	0	
16	2	15/03/2021	14:29:50	5,8	113	15,3	2,2	1539	8,9	0	0	0	
17	1	15/03/2021	14:24:43	4,2	107	16,6	2,3	1434	6	0	0	0	
18	3	15/03/2021	14:13:52	1,2	99	22,7	2,1	1407	1,7	0	0	0	
19	2	15/03/2021	14:13:00	2	104	20,7	2,3	1386	2,8	0	0	0	
20	1	15/03/2021	14:11:14	3,2	100	21,7	411,7	1311	4,2	0	0	0	
21	4	15/03/2021	13:52:07	2,6	107	18	2,2	1492	3,9	0	0	0	
22	3	15/03/2021	13:50:49	3	113	16,7	2,3	1438	4,3	0	0	0	
23	2	15/03/2021	13:49:49	3,4	107	18	2,3	1443	4,9	0	0	0	
24	1	15/03/2021	13:48:04	5,8	106	18,2	2,3	1390	8,1	0	0	0	
25	2	15/03/2021	13:35:37	4,6	117	14,8	2,3	1400	6,4	0	0	0	
26	1	15/03/2021	13:07:38	5,8	111	16,2	2,3	1332	7,7	0	0	0	
27	1	15/03/2021	12:49:19	5,6	109	15,6	2,3	1302	7,3	0	0	0	
28	1	15/03/2021	12:28:24	6	110	16,2	2,3	1319	7,9	0	0	0	
29	3	15/03/2021	12:15:24	4,4	108	16,9	2,3	1308	5,8	0	0	0	
30	2	15/03/2021	12:12:25	8	113	14,6	2,3	1314	10,5	0	0	0	
31	1	15/03/2021	12:12:01	0,6	84	25,8	1,3	946	0,6	0	0	1	
32	1	15/03/2021	11:49:47	1,4	100	17,7	2	1310	1,8	0	0	0	
33	1	15/03/2021	11:29:07	7	103	18,8	2,3	1417	9,9	0	0	0	
34	1	15/03/2021	10:45:44	9,4	110	16,2	2,3	1479	13,9	0	0	0	
35	3	15/03/2021	10:19:20	14,8	107	16,8	2,3	1517	22,5	0	0	0	
36	1	15/03/2021	10:18:30	1	80	27	1,7	1173	1,2	0	0	1	

Press the  (PREV) key to return to the previous screen.



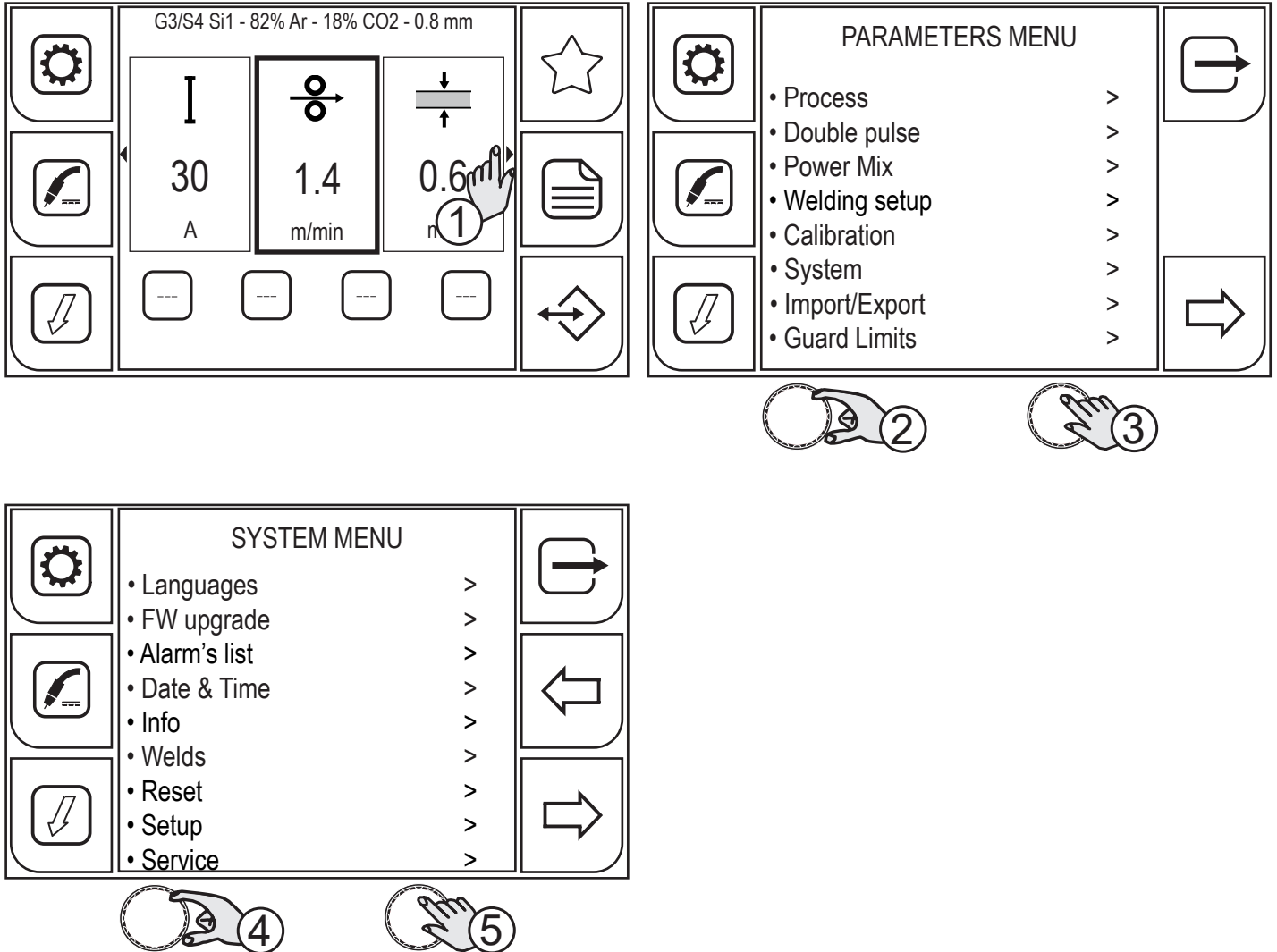

Press the  (EXIT) key to go back to the home page.

16 SERVICE

The service menu is used to activate additional functions; the password is not provided to the end user as these functions are activated by qualified technical personnel, only authorised by the manufacturer to carry out maintenance and troubleshooting tasks.



17 TECHNICAL DATA

Directives applied	Waste electrical and electronic equipment (WEEE)
	Electromagnetic compatibility (EMC)
	Low voltage (LVD)
	Restriction of the use of certain hazardous substances (RoHS)
Conformity markings	 Equipment compliant with European directives in force
	 Suitable in an environment with increased hazard of electric shock
	 Compliant with WEEE directive
	 Equipment compliant with RoHS directive
Construction standards	EN 60974-5 EN 60974-10 Class A

17.1 WF-204 TECHNICAL DATA

Supply voltage	48 V a.c.	
Dimensions (W x D x H)	245 x 670 x 470 mm	
Weight	21.5 kg	
Protection rating	IP23	
Maximum gas pressure	0,5 MPa (5 bar)	
MIG/MAG welding voltage	14.5 V - 39.0 V	
Motor speed	1.0-25.0 m/min	
Wire spool: (dimensions/weight)	200 mm / 5 kg – 300 mm / 15 kg	
Ambient temperature	40°C	
Welding mode	MIG/MAG	
Static characteristic		
Work cycle	60 %	100 %
Welding current	450 A	400 A
Operating voltage	36.5 V	34.0 V

17.2 WF-205 TECHNICAL DATA

Supply voltage	48 V a.c.	
Dimensions (W x D x H)	265 x 665 x 360 mm	
Weight	11.5 kg	
Protection rating	IP23	
Maximum gas pressure	0,5 MPa (5 bar)	
MIG/MAG welding voltage	14.5 V - 39.0 V	
Motor speed	1.0-25.0 m/min	
Wire spool: (dimensions/weight)	200 mm / 5 kg – 300 mm / 15 kg	
Ambient temperature	40°C	
Welding mode	MIG/MAG	
Static characteristic		
Work cycle	60 %	100 %
Welding current	450 A	400 A
Working voltage	36.5 V	34.0 V

18.3 CABLE HARNESS: GENERATOR - WIRE FEEDER

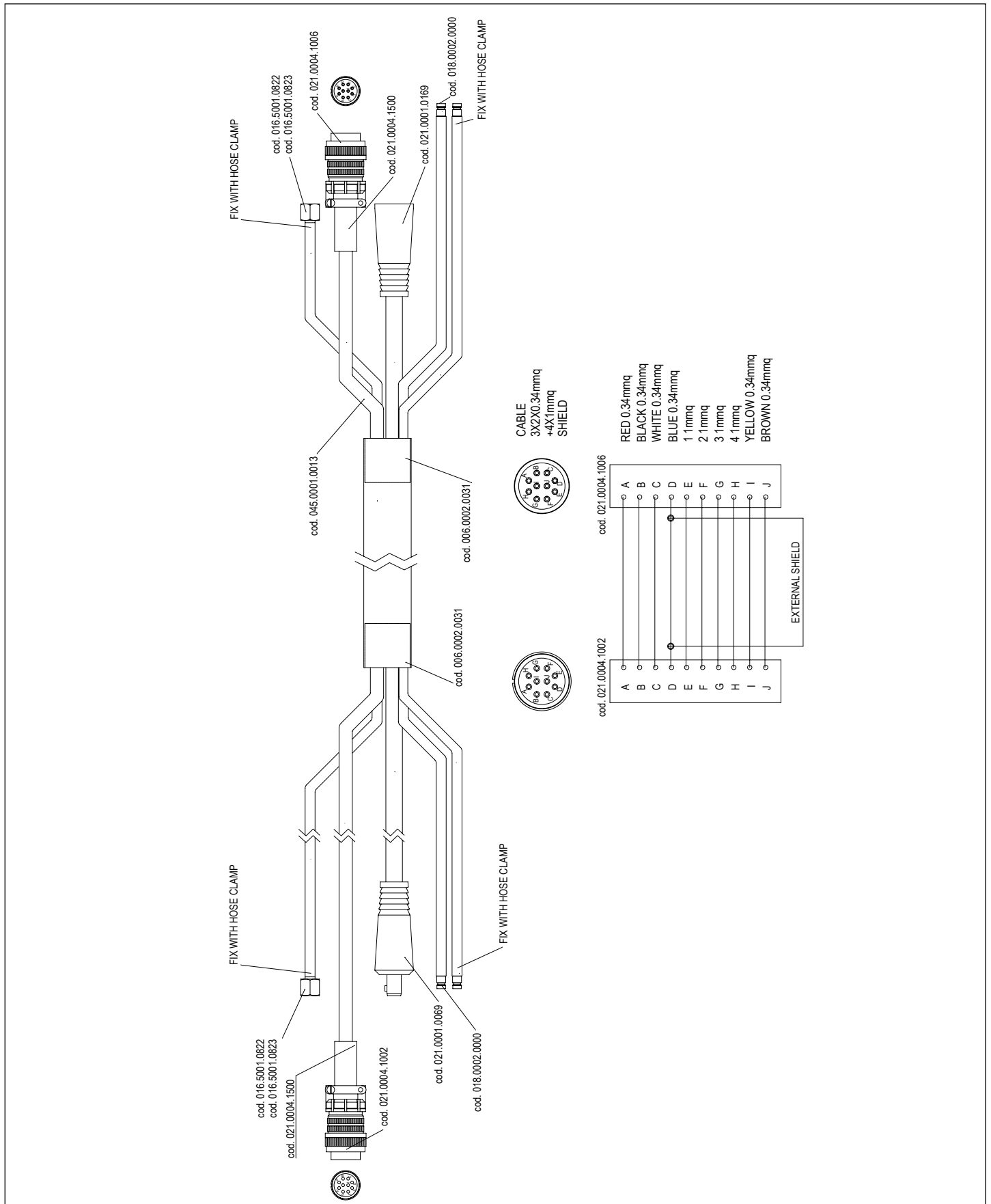

18.4 REMOTE CONTROL CONNECTOR

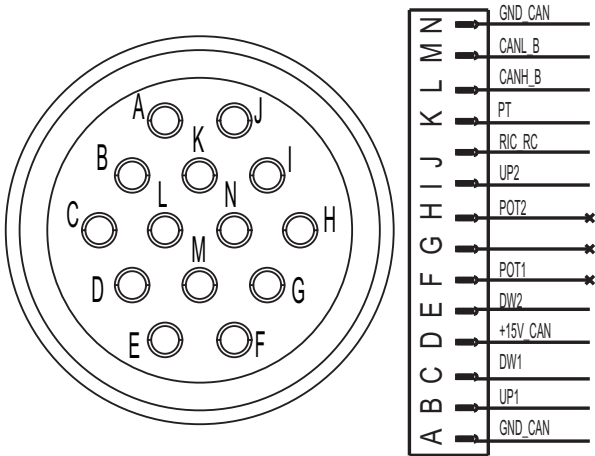

PIN	NAME	DESCRIPTION SIGNAL
A	GND_CAN	COMMON FOR POT/UP-DW/PT/CAN...
B	UP2	UP SIGNAL (Volt)
C	DW2	DOWN SIGNAL (Volt)
D	+15V_CAN	COMMON TO POWER DIGIM TORCH. or RC08
E	UP1	UP SIGNAL (m/min)
F	POT1	SIGNAL FOR POTENTIOMETER (Volt)
G	+5V	COMMON FOR POT 1 AND 2
H	POT2	SIGNAL FOR POTENTIOMETER (Volt)
I	DW1	DOWN SIGNAL (m/min)
J	RIC_RC	REMOTE ACKNOWLEDGMENT (in bridge with GND_CAN)
K	PT	TORCH BUTTON (shared with GND_CAN)
L	CANH_B	WECO OPTIONS
M	CANL_B	WECO OPTIONS
N	GND_CAN	COMMON (SAME AS PIN A)

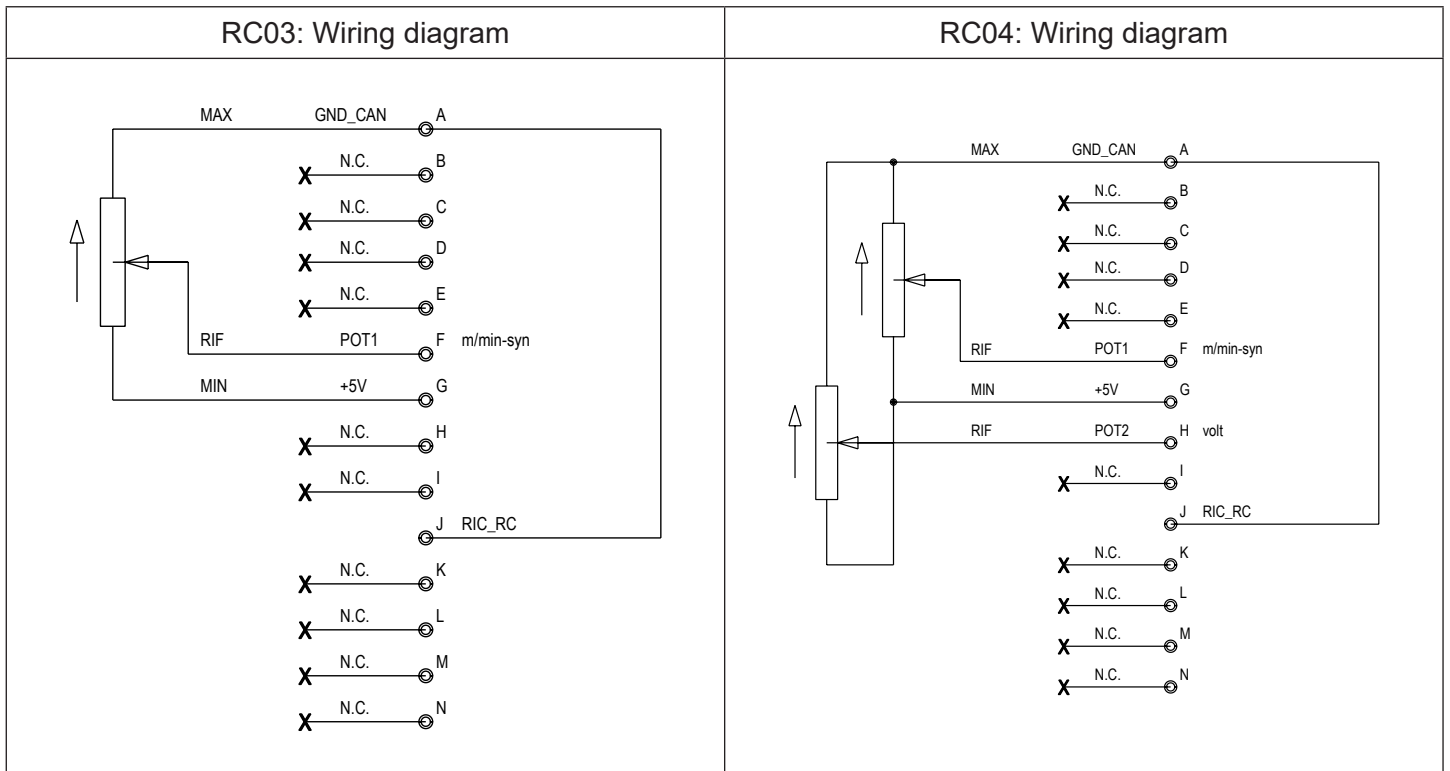

10 kOhm - 100 kOhm potentiometer

10 kOhm - 100 kOhm potentiometer

Use the adaptor code 022.0002.0383 to connect the remote control (RC03, RC04) to the unit.

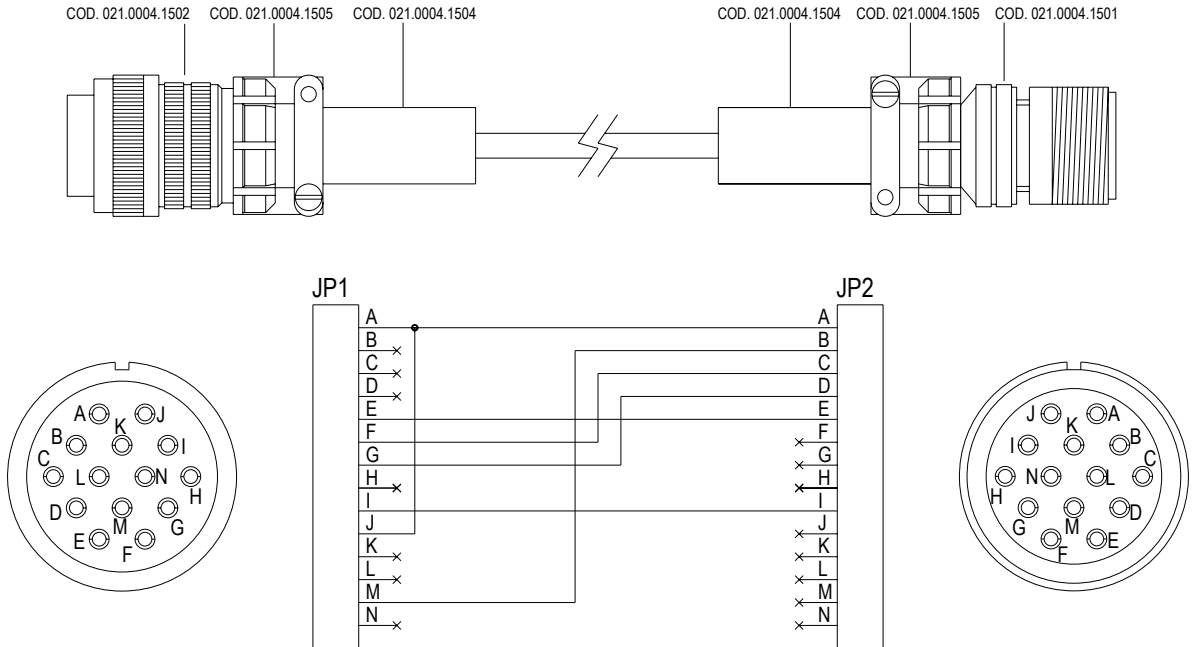

RC05: Wiring diagram

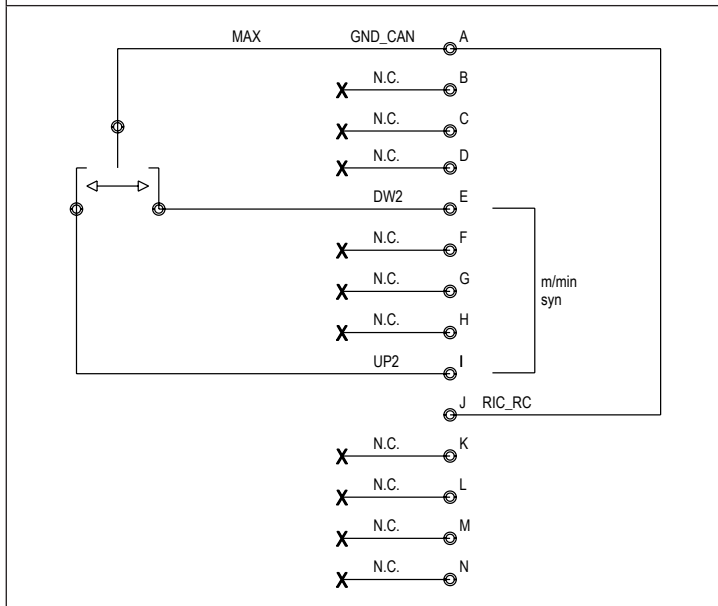

RC06: Wiring diagram

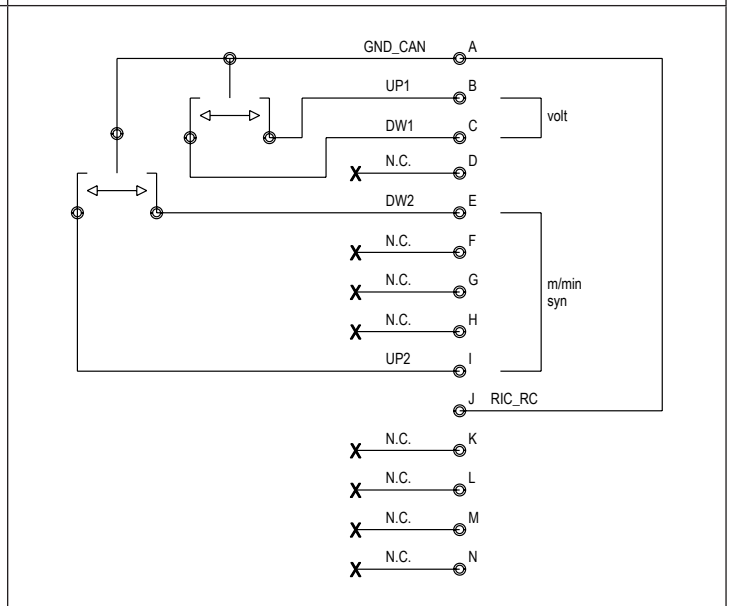

19 SPARES

19.1 WF-204



ENGLISH

No.	CODE	DESCRIPTION
1	010.0000.0060	PLEXIGLASS GUARD KIT
2	014.0002.0025	KNOB WITH CAP
3	013.0020.1101	FRONT PANEL LABEL
4	050.5333.0000	COMPLETE FRONT LOGIC PANEL
5	050.0001.0172	KEYS + ENCODER BOARD
6	012.0001.0500	FRONT PLASTIC
7	011.0014.0051	FRONT PLATE
8	011.0014.0066	HANDLE FIXING PLATE
9	021.0001.2024	CAPILLARY TUBE
10	021.0001.2000	AXIAL GAS CONNECTOR
11	011.0002.0037	BRASS GUIDE BLOCK BRACKET
12	021.0001.2019	STING
13	021.0001.2010	CURRENT CLAMP FOR BRASS GUIDE
14	011.0014.0077	MOTOR SUPPORT PLATE
15	011.0014.0054	BOTTOM COVER
16	018.0002.0004	QUICK COUPLINGS
17	017.0003.0055	NIPPLE CONNECTOR
18	046.0004.0013	PLASTIC SUPPORT
19	016.5001.3040	PIPE RUBBER HOLDER =6mm F=1/8 F
20	022.0002.0372	10 PIN MILITARY SPEC. CONNECTOR CABLING
21	011.0002.0018	SOLENOID VALVE PLATE
22	017.0001.5543	SOLENOID VALVE
23	045.0006.0054	COPPER BRACKET
24	011.0014.0069	COVER PLATE RS232
25	011.0001.0761	SIDE COVER
26	011.0014.0073	FIXING CABLE HARNESS PLATE
27	011.0014.0026	SUPPORT CABLE HARNESS PLATE
28	021.0001.0379	FIXED PLUG 500A 95mmq
29	021.0001.0279	FIXED SOCKET 500A 95mmq
30	011.0014.0059	SIDE SUPPORT PLATE
31	050.0002.0131	WIRE FEEDER 4Q BOARD
32	011.0014.0052	INTERNAL MOUNTING PLATE
33	011.0014.0056	REAR PLATE
34	012.0001.0502	REAR PLASTIC PANEL
35	011.0014.0061	PIPE HANDLE
36	011.0014.0057	TOP HOOD RETAINER PLATE
37	011.0006.0062	FULL SPOOL MOUNTING
38	002.0000.0287	SCREW CAP FOR SPOOL SUPPORT
39	011.0001.0741	UPPER COVER
40	011.0006.0007	PLASTIC HINGE
41	011.0006.0002	SLIDE CLOSURE
42	011.0001.0751	DOOR PLATE

No.	CODE	DESCRIPTION
43	013.0000.0153	INTERNAL KEYS STICKER
44	011.0014.0060	FRONT BOARD SAFETY PLATE
45	050.0001.0161	BUTTONS BOARD
46	021.0001.2004	EURO CONNECTOR INSULATOR
47	002.0000.0023	WIRE FEED MOTOR
48	022.0002.0371	14 PIN MILITARY SPEC. CONNECTOR CABLING
49	017.0003.0025	SWIVEL RING FITTING LF= 1/8
50	017.0003.0023	HOLLOW BOLT M= 1/8
51	011.0014.0058	WIRE FEEDER COVER PLATE
52	021.0004.2994	MS-20 CONNECTOR CAP

19.2 WF-205

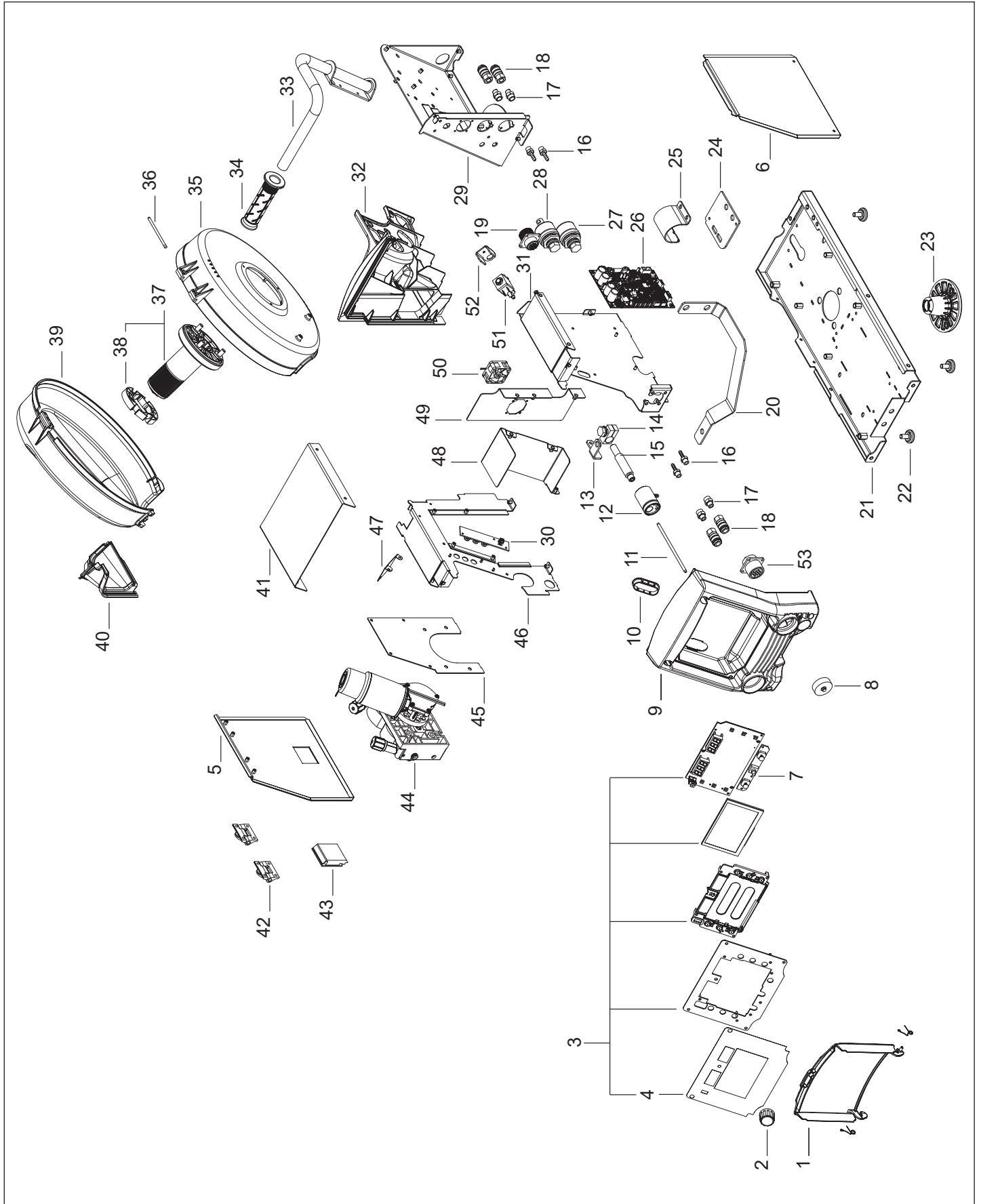

ENGLISH

No.	CODE	DESCRIPTION
1	010.0000.0093	PLEXIGLASS GUARD KIT
2	014.0002.0025	KNOB WITH CAP
3	050.5328.0000	COMPLETE LOGIC FRONT PANEL
4	013.0020.1001	FRONT PANEL LABEL
5	011.0001.1091	DOOR PLATE
6	011.0001.1081	LATERAL COVER
7	050.0001.0172	KEYS + ENCODER BOARD
8	021.0004.2994	MS-20 CONNECTOR CAP
9	012.0011.0010	FRONT PLASTIC
10	016.0011.0015	OVAL SHAPED CAP
11	021.0001.2025	EURO CONNECTOR CAPILLARY TUBE
12	021.0001.2001	AXIAL GAS CONNECTOR
13	011.0002.0039	BRASS GUIDE BLOCK BRACKET
14	021.0001.2010	CURRENT CLAMP FOR BRASS GUIDE
15	021.0001.2018	STING
16	016.5001.3040	SLEEVE HOSE ADAPTER FOR RUBBER HOSE = 6mm F= 1/8 F
17	017.0003.0055	NIPPLE CONNECTOR
18	018.0002.0004	QUICK CLUTCH
19	022.0002.0330	10 PIN MILITARY SPEC. CONNECTOR CABLING
20	045.0006.0103	COPPER BRACKET
21	011.0014.0151	BOTTOM COVER
22	016.0009.0003	RUBBER FOOT
23	012.0009.0010	PLASTIC SUPPORT
24	011.0014.0157	FIXING CABLE BUNDLE PLATE
25	011.0014.0026	SUPPORT CABLE BUNDLE PLATE
26	050.0002.0131	WIRE FEEDER 4Q BOARD
27	021.0001.0279	FIXED SOCKET 500A 95mmq
28	021.0001.0379	FIX PLUG 500A 95mmq
29	011.0014.0152	SPOOL SUPPORT PLATE
30	050.0001.0161	BUTTONS BOARD
31	011.0014.0153	INTERNAL PLATE
32	012.0010.0010	REAR NYLON
33	011.0014.0158	HANDLE TUBE
34	011.0006.0032	RUBBER HANDLE
35	012.0000.0003	LOWER SPOOL COVER
36	016.0008.0003	CYLINDRICAL PLUG
37	011.0006.0062	COMPLETE SPOOL SUPPORT
38	002.0000.0287	SPOOL HOLDER METAL RING
39	012.0000.0004	UPPER SPOOL COVER
40	012.0013.0010	PLASTIC WATER GUARD
41	011.0001.1071	UPPER COVER

No.	CODE	DESCRIPTION
42	011.0006.0007	PLASTIC HINGE
43	011.0006.0003	SLIDE CLOSURE
44	002.0000.0023	WIRE FEED MOTOR
45	011.0014.0156	MOTOR PROTECTION PLATE
46	011.0014.0150	INTERNAL LEFT PLATE
47	011.0014.0161	MOTOR COMPARTMENT PLATE
48	011.0014.0160	INTERNAL PLATE
49	011.0014.0163	FAN SUPPORT PLATE
50	003.0002.0021	FAN
51	017.0001.5543	SOLENOID VALVE
52	011.0002.0018	SOLENOID VALVE PLATE
53	022.0002.0329	14 PIN MILITARY SPEC. CONNECTOR CABLING

19.3 WIRE FEEDER MOTOR

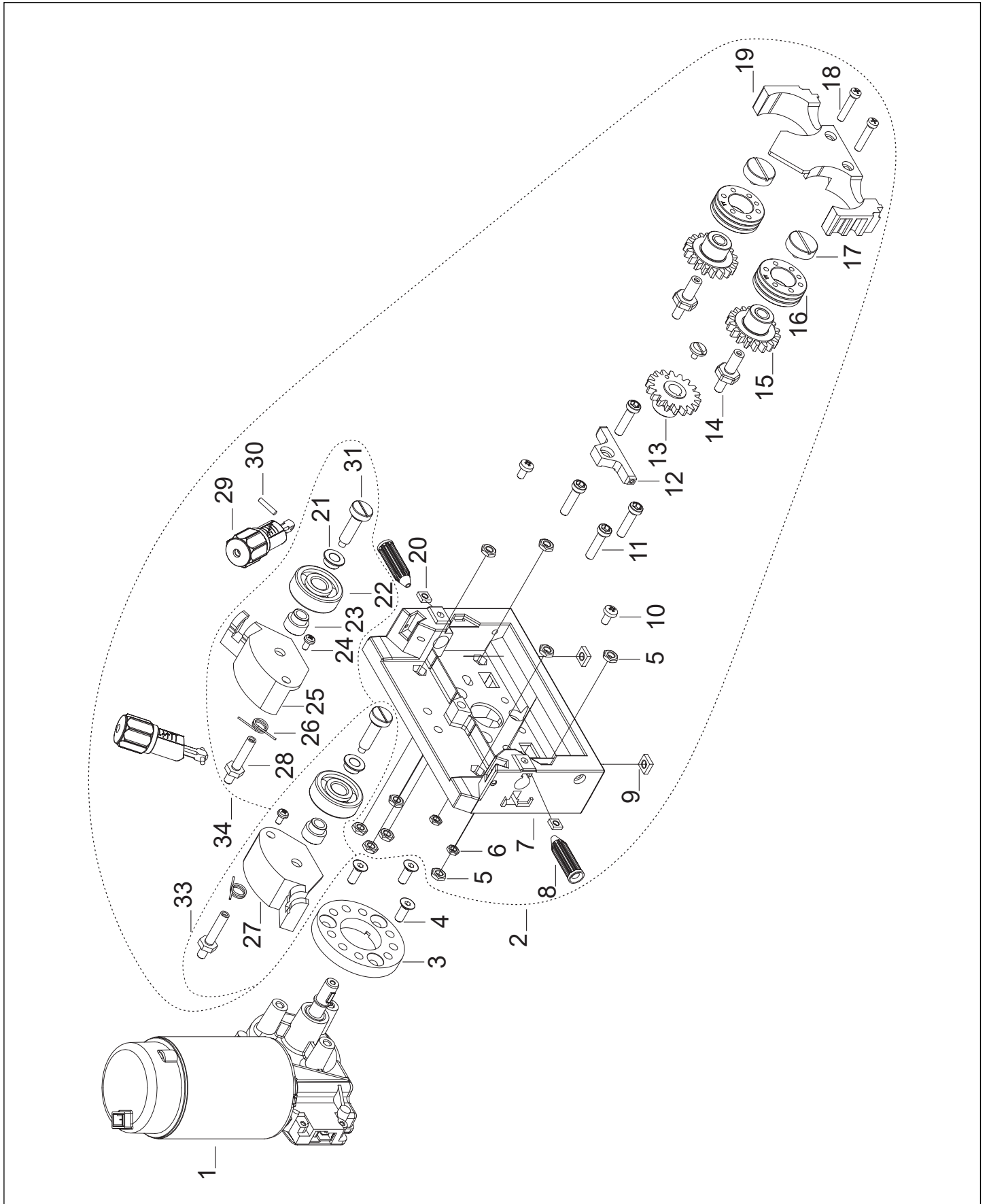

ENGLISH

No.	CODE	DESCRIPTION
1	002.0000.0392	MOTOR COIL
2	002.0000.0062	WIRE FEEDER BODY COMPLETE
3	002.0000.0390	DISTANCE RING
4	016.0300.0411	COUNTERSUNK SCREW M6x12
5	002.0000.0349	HEXAGONAL NUT M6
6	002.0000.0384	HEXAGONAL NUT M5
7	002.0000.0373	WIRE FEEDER SUPPORT
8	002.0000.0297	INLET GUIDE
9	002.0000.0385	SQUARE NUT M6
10	002.0000.0324	SCREW M5x10
11	002.0000.0387	SCREW M6x25
12	002.0000.0294	INTERMEDIATE GUIDE
13	002.0000.0300	MAIN GEAR DRIVE
14	002.0000.0374	SHAFT
15	002.0000.0299	GEAR ADAPTOR FEED ROLL (BRONZE BUSHING)
15	002.0000.0309	GEAR ADAPTOR FEED ROLL (BALL BEARING)
16	002.0000.0142	FEED ROLL
17	002.0000.0383	RETAINING SCREW M4
18	002.0000.0382	SCREW M5x30
19	002.0000.0388	INTERNAL GUARD
20	002.0000.0386	SQUARE NUT M5
21	002.0000.0315	DISTANCE RING 1
22	002.0000.0303	SMOOTH DRIVE ROLL
23	002.0000.0314	DISTANCE RING 2
24	002.0000.0318	SCREW M4x8
25	002.0000.0379	RIGHT PRESSURE ARM
26	002.0000.0317	SPRING
27	002.0000.0378	COMPLETE LEFT PRESSURE ARM
28	002.0000.0375	JOINT AXLE
29	002.0000.0381	COMPLETE PRESSURE DEVICE
30	002.0000.0319	PIN
31	002.0000.0380	PRESSURE ROLL AXLE
32	002.0000.0304	SCREW M4x10
33	002.0000.0376	COMPLETE LEFT PRESSURE ARM
34	002.0000.0377	COMPLETE RIGHT PRESSURE ARM

19.4 WIRE FEED ROLLERS

Standard					
Code	Ø wire	Type	Ø roll	Grooves	
002.0000.0140	0.6-0.8	V groove Solid wires (steel - stainless steel)	D=37x12/d=19 V	35° V	
002.0000.0141	0.8-1.0				
002.0000.0142	1.0-1.2				
002.0000.0143	1.2-1.6				
002.0000.0144	0.8-1.0	U shape Aluminium wires	D=37x12/d=19 U	90° V	
002.0000.0145	1.0-1.2				
002.0000.0146	1.2-1.6				
002.0000.0147	1.6-2.0				
002.0000.0148	2.4-3.2				
002.0000.0149	1.0-1.2	VK shape Tubular wires	D=37x12/d=19 VK	90° V	
002.0000.0150	1.2-1.6				
002.0000.0151	2.4-3.2				

Arm with standard roll	
Smooth	
Code	Ø roll
002.0000.0303	D=37x12/d=12 Standard SMOOTH

Double driving roll (4 rolls with grooves) - RECOMMENDED SETUP

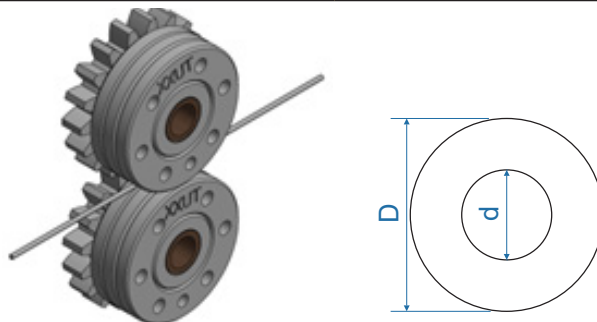

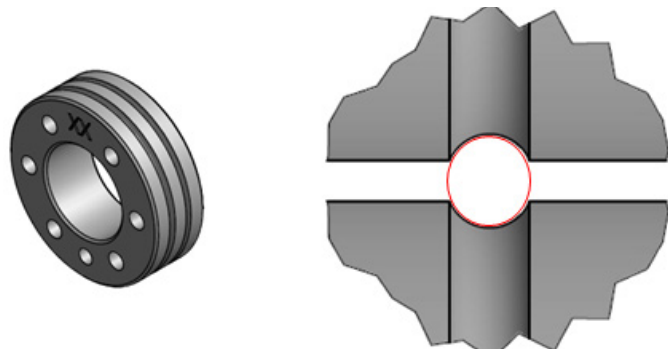
Code	Ø wire	Ø roll	
002.0000.0168	1.0-1.2	D=37x12/d=19 U DOUBLE D.	
002.0000.0169	1.2-1.6	D=37x12/d=19 U DOUBLE D.	
002.0000.0171	1.0-1.2	D=37x12/d=19 UT TEFLON.	
002.0000.0172	1.2-1.6	D=37x12/d=19 UT TEFLON	

Toothed wheels for dual drive roller

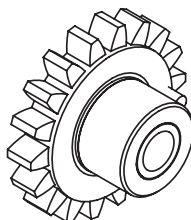

002.0000.0299	Gear adaptor feed roller (with bronze bushings)
002.0000.0309	Gear adaptor feed roller (with ball bearings)

Dual drive roller (2 rollers with grooves, 2 flat rollers)

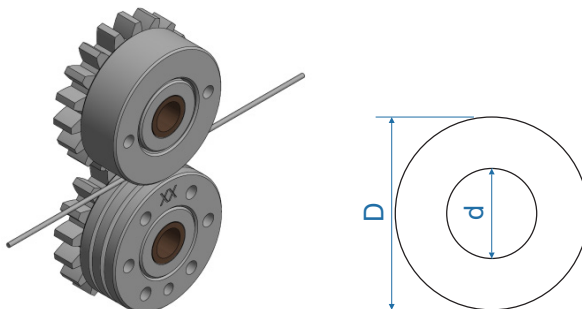

Code	Ø wire	Ø roll	
002.0000.0145	1.0-1.2	D=37x12/d=19 U	
002.0000.0146	1.2-1.6	D=37x12/d=19 U	
002.0000.0149	1.0-1.2	D=37x12/d=19 VK	
002.0000.0150	1.2-1.6	D=37x12/d=19 VK	
002.0000.0151	2.4-3.2	D=37x12/d=19 VK	

Toothed wheels for dual drive roller

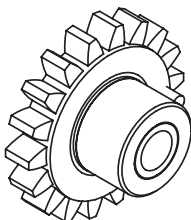

002.0000.0299	Gear adaptor feed roll (with bronze bushings)
002.0000.0309	Gear adaptor feed roll (with ball bearings)

Support with dual drive roller

Smooth		Knurled	
Code	Ø roller	Code	Ø roller
002.0000.0152	D=37x12/d=19 SMOOTH for dual drive roller	002.0000.0153	D=37x12/d=19 KNURLED for dual drive roller

Kit provided to switch from "STANDARD" wire feeder to wire feeder with "Dual driver roller".

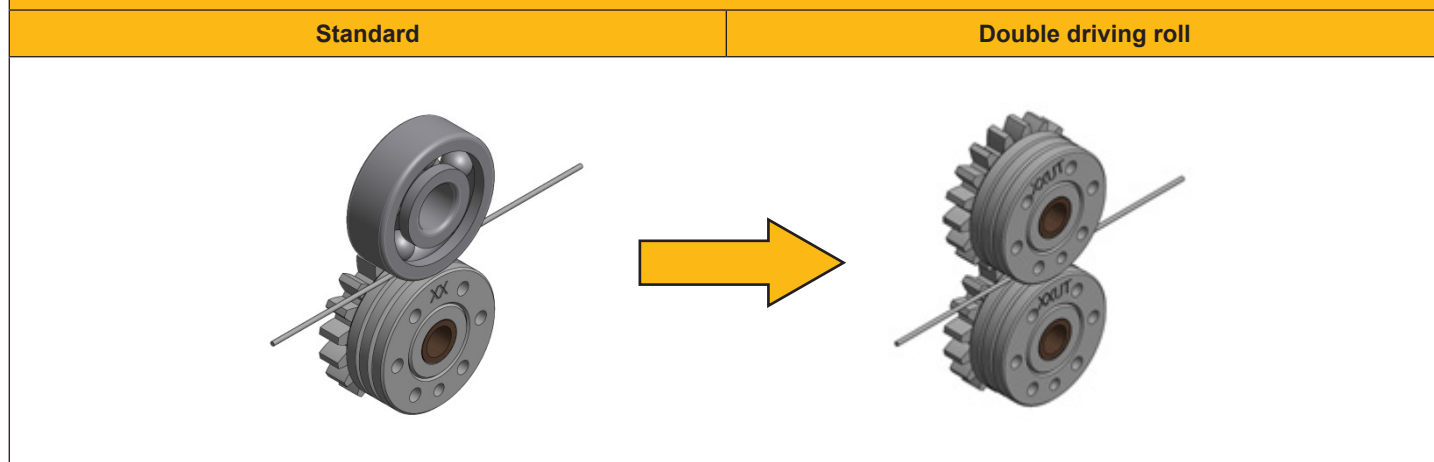

If you wish to switch from the setup with "STANDARD" wire feed rollers to the setup with "DUAL DRIVE ROLLER", the following components must be ordered:

N° 4 Special "U DOUBLE D" rolls (refer to Item A)

N° 2 Gear adaptor feed rolls (refer to Item B) [it is recommended with bronze bushings]

Code	Ø wire	Ø roller	
002.0000.0168	1.0-1.2	D=37x12/d=19 U DOUBLE D.	<div style="display: flex; align-items: center;"> <div style="margin-right: 10px;"> A </div> </div> <p style="margin-top: 10px; font-size: 24px; font-weight: bold;">x 4</p>
002.0000.0169	1.2-1.6	D=37x12/d=19 U DOUBLE D.	

Gears for double driving roll

002.0000.0299	Gear adaptor feed roll (with bronze bushings)	<div style="display: flex; align-items: center;"> <div style="margin-right: 10px;"> B </div> </div> <p style="margin-top: 10px; font-size: 24px; font-weight: bold;">x 2</p>
002.0000.0309	Gear adaptor feed roll (with ball bearings)	



WELD THE WORLD

WECO srl

www.weco.it

