



WELD THE WORLD

CU-23/CU-23 HP CU-28/CU-28 HP

Instruction Manual







WELD THE WORLD

INDEX

1	INTRODUCTION.....	4
1.1	PRESENTATION.....	5
2	INSTALLATION	5
2.1	FRONT PANEL	5
2.2	REAR PANEL.....	6
2.3	ASSEMBLY WITH THE WELDING POWER SOURCE	7
3	TECHNICAL DATA	9
3.1	CU-23/CU-23 HP	9
3.2	CU-28/CU-28 HP	9
4	WIRING DIAGRAM.....	11
4.1	CU-23/CU-23 HP	11
4.2	CU-28/CU-28 HP	12
5	SPARES.....	13
5.1	CU-23/CU-23 HP	13
5.2	PRE-ASSEMBLED FITTINGS KIT.....	15
5.3	CU-28/CU-28 HP	17
5.4	PRE-ASSEMBLED FITTINGS KIT.....	19

1 INTRODUCTION

 	IMPORTANT!
<p><i>This handbook must be consigned to the user prior to installation and commissioning of the unit. Read the "GENERAL PRESCRIPTIONS FOR USE" handbook supplied separately from this manual before installing and commissioning the unit. The meaning of the symbols in this manual and the associated precautionary information are given in the "GENERAL PRESCRIPTIONS FOR USE". If the "GENERAL PRESCRIPTIONS OF USE" are not present, it is mandatory to request a replacement copy from the manufacturer or from your dealer. Retain these documents for future consultation.</i></p>	

KEY

	DANGER!
<p><i>This pictogram warns of danger of death or serious injury.</i></p>	

	WARNING!
<p><i>This pictogram warns of a risk of injury or damage to property.</i></p>	

	CAUTION!
<p><i>This pictogram warns of a potentially hazardous situation.</i></p>	

	INFORMATION!
<p><i>This pictogram gives important information concerning the execution of the relevant operations.</i></p>	

NOTES

The figures in this manual are purely guideline and the images may contain differences with respect to the actual equipment to which they refer.

1.1 PRESENTATION

The cooling unit CU-23/CU-23 HP/CU-28/CU-28 HP can be connected to the power source, allowing the liquid cooling of the TIG and MIG/MAG torches.

The CU-23/CU-23 HP/CU-28/CU-28 HP cooling unit is fitted with a pressure switch provided to detect fluid in the cooling circuit.

2 INSTALLATION

2.1 FRONT PANEL

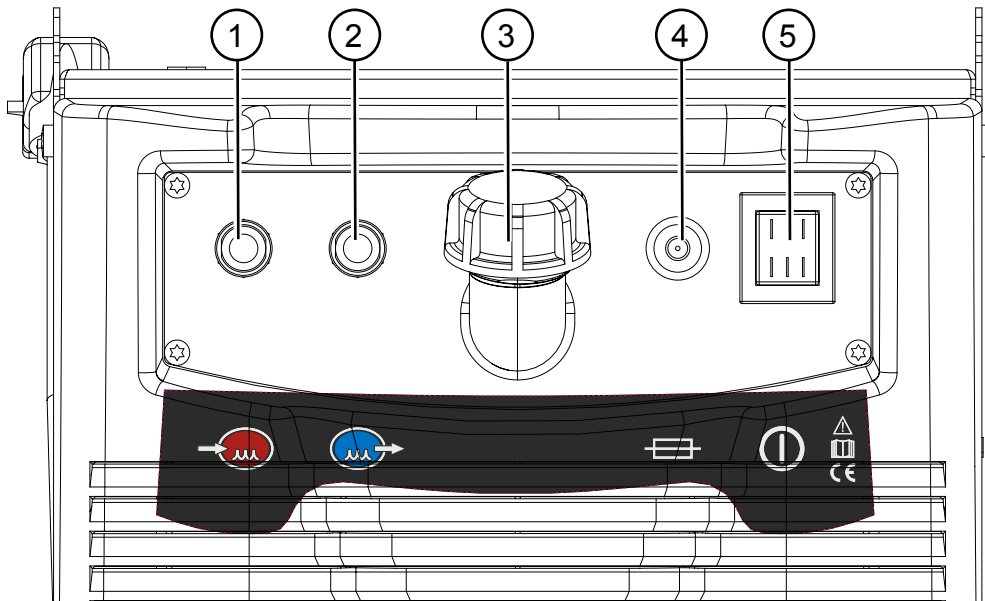

- Cooling fluid pipe connector (inlet): fluid flow from the power source/torch to the cooling unit [Item 1].
- Cooling fluid pipe connector (outlet): fluid flow from the cooling unit to the power source/torch [Item 2].
- Tank filling inlet [Item 3].
- Safety fuse [Item 4].
 - Type: Delayed acting (T)
 - Amperage: 1.6 A
 - Voltage: 500 VAC
- On and off switch [Item 5]

2.2 REAR PANEL

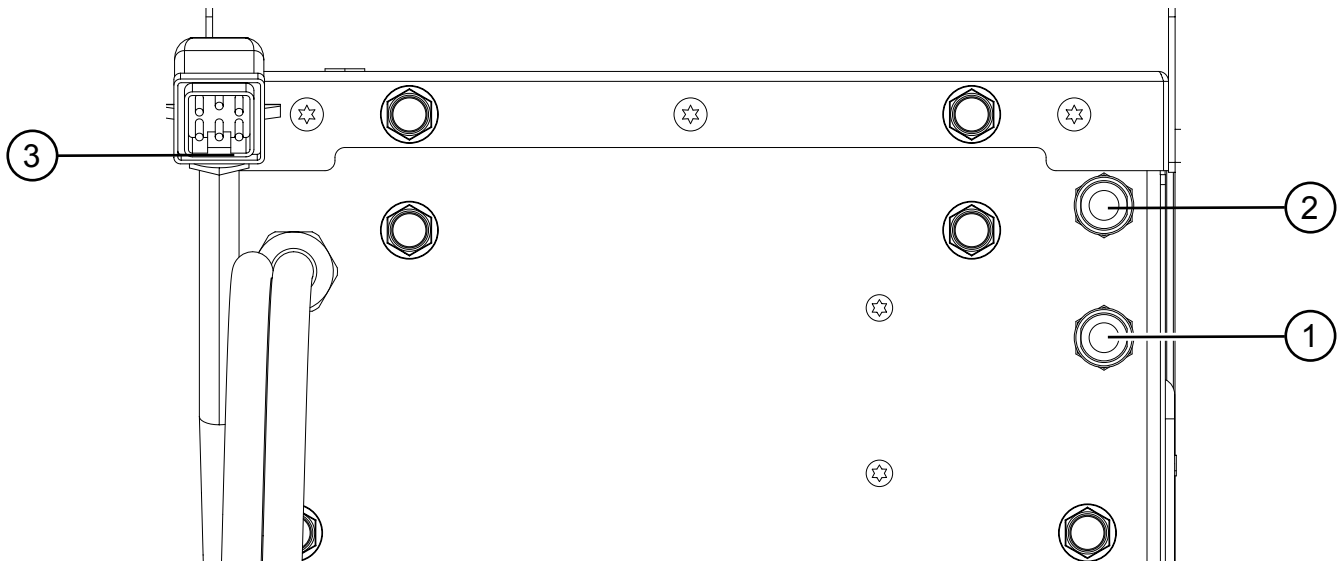





- Cooling fluid pipe connector : fluid flow from the power source to the cooling unit [Item 1].
- Cooling fluid pipe connector: fluid flow from the cooling unit to the power source [Item 2].
- CU-23/CU-23 HP/CU-28/CU-28 HP power cable [Item 3].
 - Length (outer side): 0,43 m
 - Number and cross section of wires: 5 x 1 mm²
 - Power plug type: ILME CUST 90° 5P+PE, 16 A 230 / 400 VAC
- CU-20 power cable [Item 3].
 - Length (outer side): 0,43 m
 - Number and cross section of wires: 8 x 1 mm²
 - Power plug type: ILME CUST 90° 8P+PE, 16 A 230 / 400 VAC

2.3 ASSEMBLY WITH THE WELDING POWER SOURCE

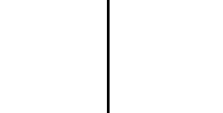
**DANGER!**
Lifting and positioning

Read the warnings highlighted by the following symbols in the "General prescriptions for use".



1. Set the welding power source ON/OFF switch to "O" (unit switched off).
2. Remove the screws from the power source cabinet.

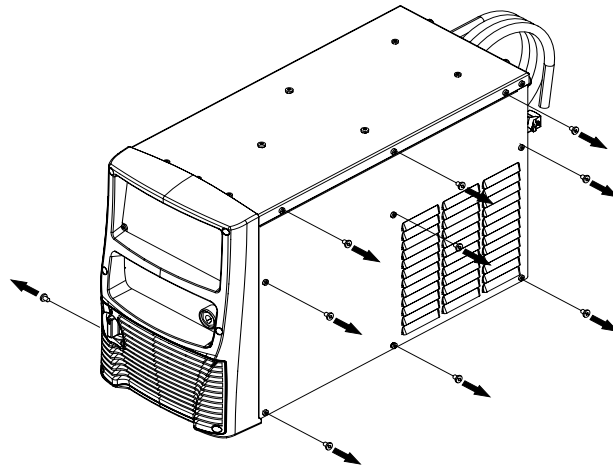

3. Loosen the screws of the upper brackets of the cooling unit and open out the brackets slightly.
4. Place the power source on top of the cooling unit.
5. Secure the cooling unit brackets to the power source using the previously removed screws.

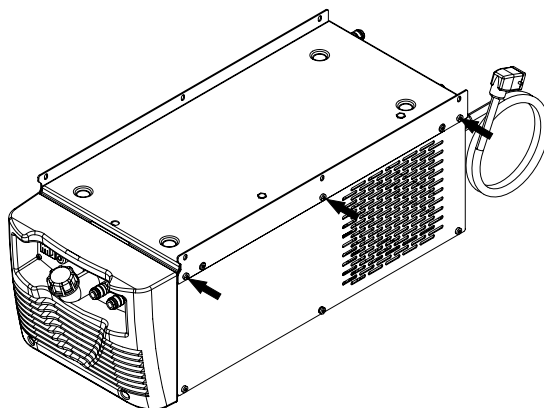

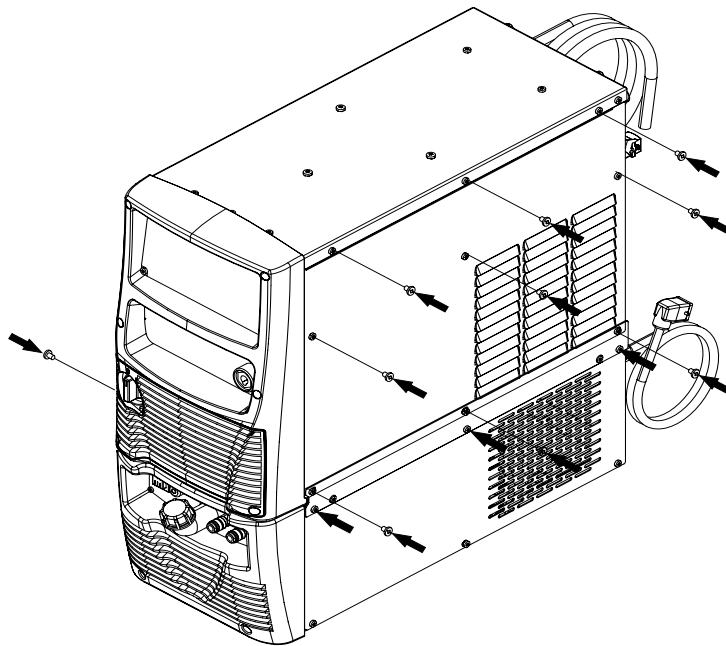

6. Connect the plug of the cooling unit power cable to the cooling unit power socket on the rear panel of the welding power source.
7. Plug the power cable plug into a mains socket outlet.
8. Set the welding power source ON/OFF switch to "I" to switch on the unit.
9. Set the cooling unit ON/OFF switch to "I" (unit on).







WARNING!

***Periodically checking the level of the liquid in the indicator on the side of the cooling unit.
Be careful when choosing the cooling liquid: it must not be an electricity conductor.
Do not use polypropylene liquids because they damage the seals and generate incrustations.
Read the warnings highlighted by the following symbols in the "General prescriptions for use".***



3 TECHNICAL DATA

Directives applied	Waste electrical and electronic equipment (WEEE)
	Electromagnetic compatibility (EMC)
	Low voltage (LVD)
	Restriction of the use of certain hazardous substances (RoHS)
Construction standards	EN 60974-2; EN 60974-10 Class A
Conformity markings	 Equipment compliant with European directives in force
	 Suitable in an environment with increased hazard of electric shock
	 Compliant with WEEE directive
	 Equipment compliant with RoHS directive

3.1 CU-23/CU-23 HP

Supply voltage	1 x 400 V a.c. ± 15 % / 50-60 Hz
Dimensions (D x L x H)	720 x 290 x 235 mm
Weight	30.0 kg with liquid
Tank capacity	4.5 l
Protection rating	IP23
Maximum input current (A)	1.35 A (50 Hz) – 1.53 A (60 Hz)
Cooling power	950 W (1l/min)–2.8 KW (max l/min)
Maximum pressure (CU-23)	0.32 MPa (50 Hz) – 0.43 MPa (60 Hz)
Maximum pressure (CU-23 HP)	0.41 MPa (50 Hz) – 0.51 MPa (60 Hz)

3.2 CU-28/CU-28 HP

Supply voltage	1 x 400 V a.c. ± 15 % / 50-60 Hz 1 x 230 V a.c. ± 15 % / 50-60 Hz
Dimensions (D x L x H)	720 x 290 x 235 mm
Weight	31.4 kg with liquid
Tank capacity	4.5 l
Protection rating	IP23
Maximum input current (A)	with 400 VAC power supply 0.7 A (50 Hz) with 230 VAC power supply 1.2 A (50 Hz)
Cooling power	1650 W (1l/min)
Maximum pressure (CU-28)	0.33 MPa (50 Hz)–0.44 MPa (60 Hz)
Maximum pressure (CU-28 HP)	0.41 MPa (50 Hz)–0.51 MPa (60 Hz)

The technical characteristics of the antifreeze liquid supplied with this appliance are found below:

Base	Refrigerants polymers with low pour point
Appearance	Liquid
Color	Colorless
Odor	Odorless
Specific weight	1.030 g/cm ³
Viscosity	< 100 cP
pH	7 / 8
Refractive index	1.369 nD (20 °C)
Boiling point	102 °C
Specific heat	3.9 kJ/kg K
Thermal conductivity	0.45 W/m k (25 °C)
Electrical conductivity	2.3 mS/cm (20 °C)
Dissolved chloride	< 2 ppm
Dissolved sulfides	< 2 ppm
Hardness	< 0.1 mol/m ³ (Ca ⁺⁺ , Mg ⁺⁺)
Biodegradability	Complete
Foaming power	No
Solubility	Soluble in water

4 WIRING DIAGRAM
4.1 CU-23/CU-23 HP

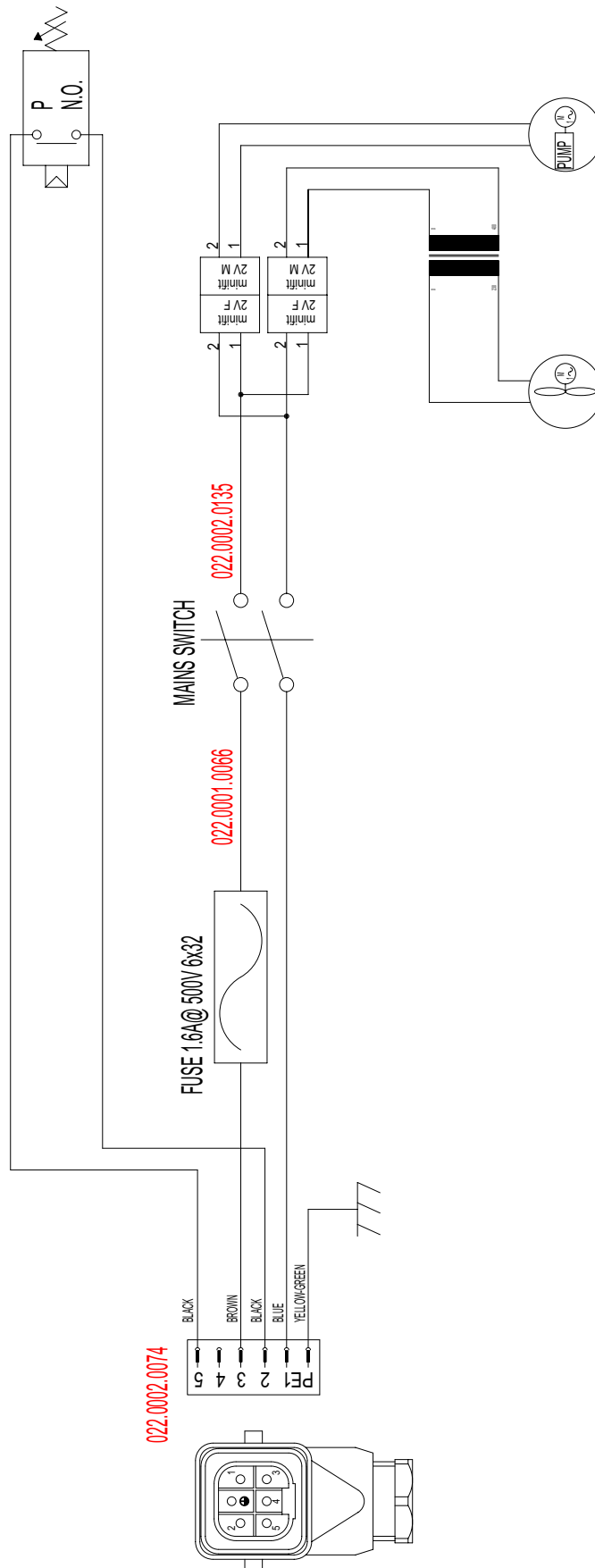

ENGLISH

4.2 CU-28/ CU-28 HP

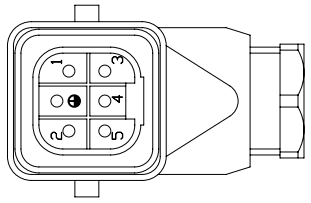
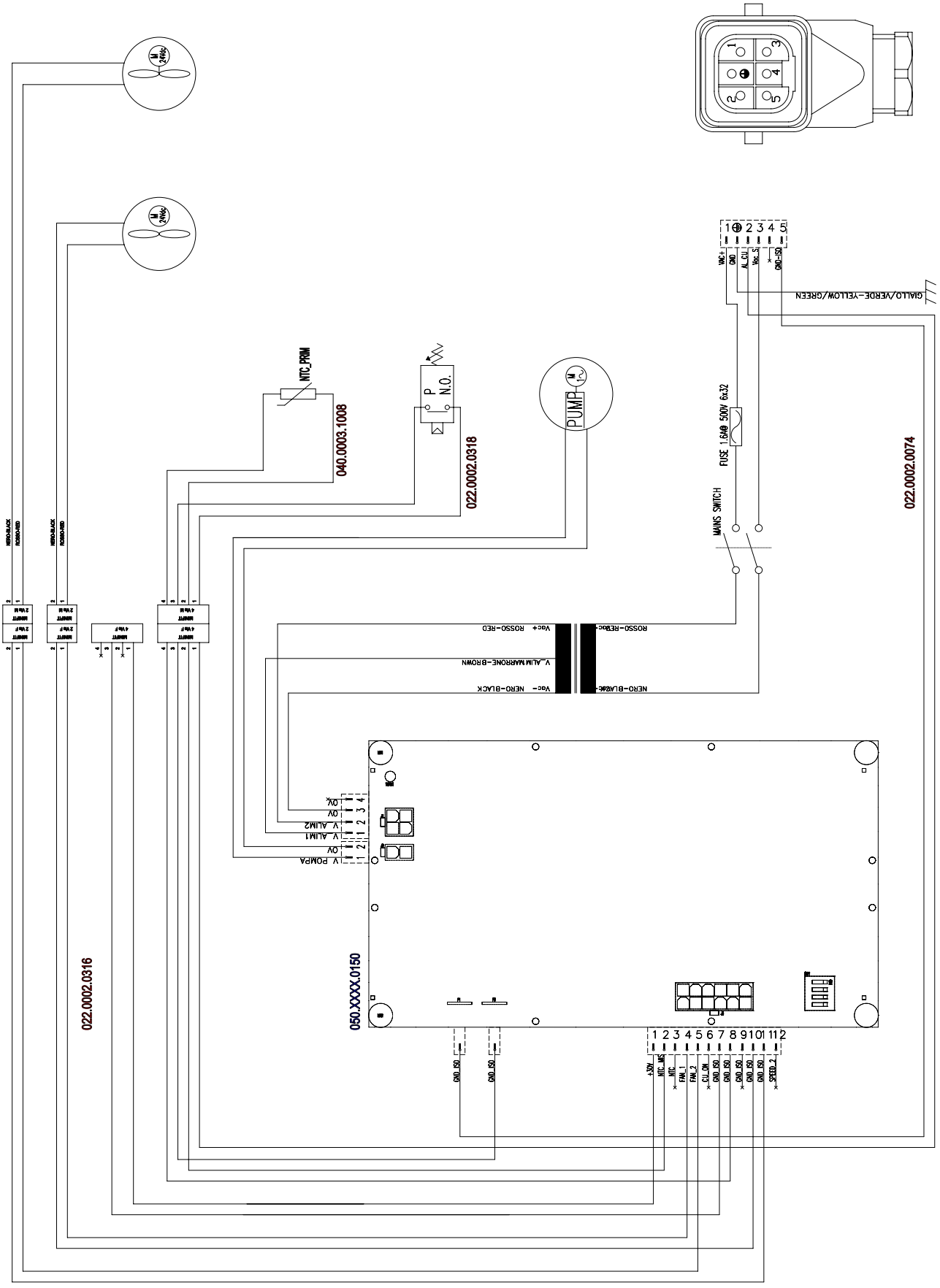

5 SPARES
5.1 CU-23/CU-23 HP

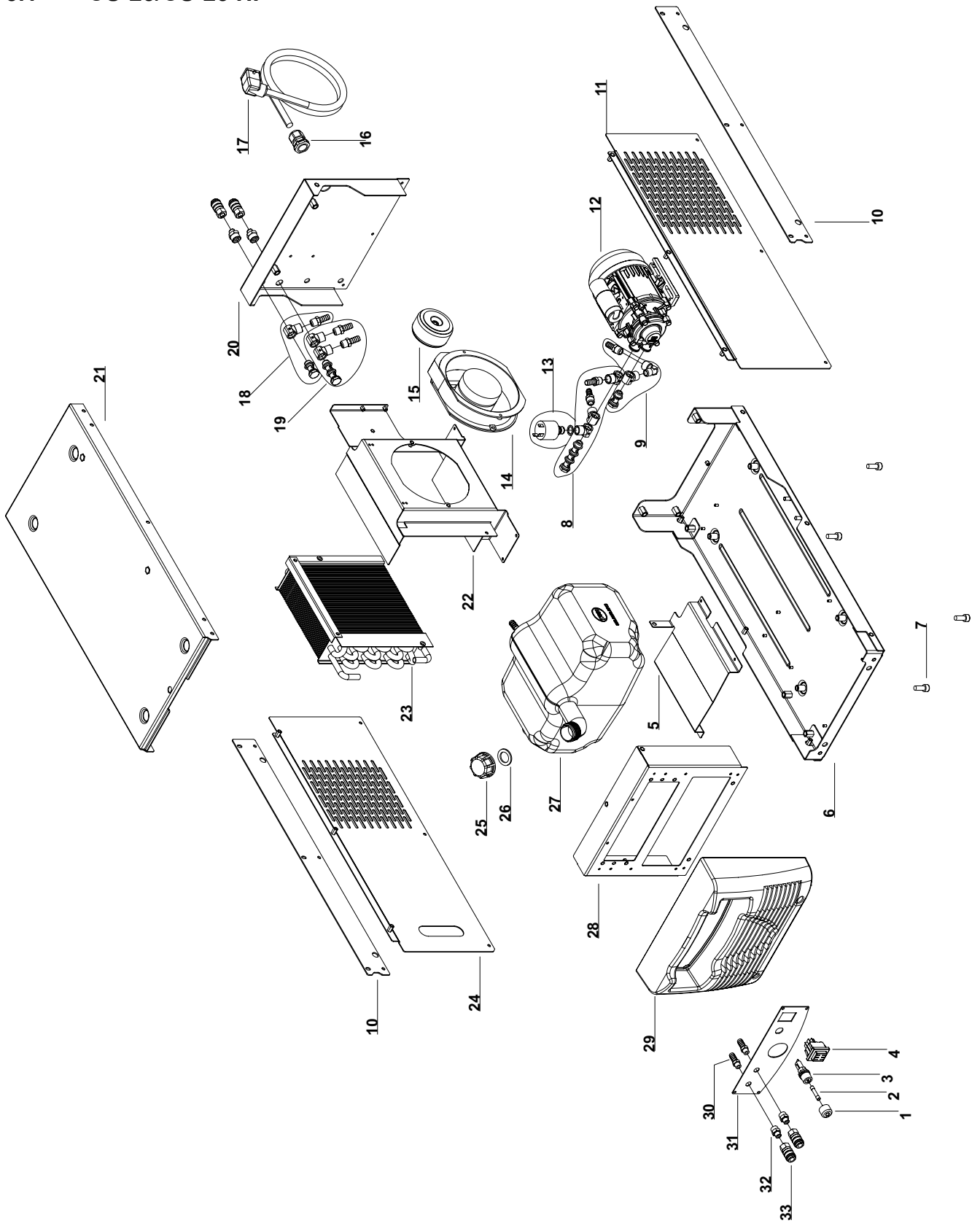

ENGLISH

No.	CODE	DESCRIPTION
1	016.0011.0004	FUSE HOLDER CAP
2	040.0007.1160	FUSE
3	040.0006.1880	FUSE HOLDER
4	040.0001.0003	SWITCH
5	011.0012.0106	TANK FIXING PLATE
6	011.0012.0150	LOWER CASE
7	016.0201.0624	SCREW M8 H=20mm T.C.E.I. Z.B
8	010.0000.0084	PUMP CONNECTION KIT (I)
9	010.0000.0085	PUMP CONNECTION KIT (L)
10	011.0012.0154	CLAMPING PLATE
11	011.0000.1211	RIGHT SIDE COVER
12	003.0004.0026	PUMP
12	003.0004.0041	PUMP (HP VERSION)
13	010.0000.0079	PRESSURE SWITCH KIT (C)
14	003.0002.0016	FAN
15	041.0006.0008	TRANSFORMER
16	045.0000.0014	CABLE CLAMP
17	022.0002.0074	POWER SUPPLY CABLE
18	010.0000.0082	PUMP CONNECTION KIT (G)
19	010.0000.0083	PUMP CONNECTION KIT (H)
20	011.0012.0151	REAR PLATE
21	011.0012.0152	UPPER COVER
22	011.0012.0153	FAN SUPPORT PLATE
23	003.0003.0014	RADIATOR
24	011.0000.1201	LEFT SIDE COVER
25	003.0003.0015	TANK CAP
26	003.0003.0016	GASKET
27	003.0003.0013	TANK
28	011.0012.0101	FRONT PLATE
29	012.0006.0100	FRONT PLASTIC PANEL
30	016.5001.3041	SLEEVE HOSE ADAPTER FOR RUBBER HOSE Ø= 10 mm F= 1/8 M
31	011.0012.0103	CONNECTIONS FRONT PLATE
32	017.0003.0055	F=1/8 - M=1/8 NIPPLE CONNECTOR
33	018.0002.0004	QUICK CLUTCH 1/8 GAS

5.2 PRE-ASSEMBLED FITTINGS KIT

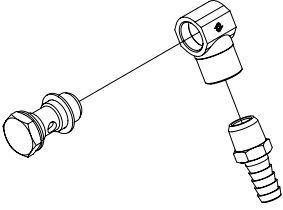
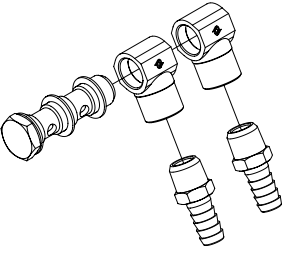
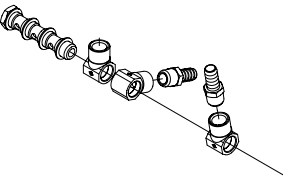
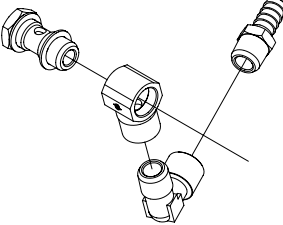
No.	CODE	DESCRIPTION
	010.0000.0082	PUMP FITTING KIT (G)
	010.0000.0083	PUMP FITTING KIT (H)
	010.0000.0084	PUMP FITTING KIT (I)
	010.0000.0085	PUMP FITTING KIT (L)

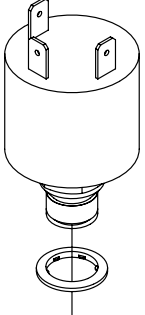
	010.0000.0079	PRESURE SWITCH KIT (C)
---	---------------	------------------------

5.3 CU-28/CU-28 HP

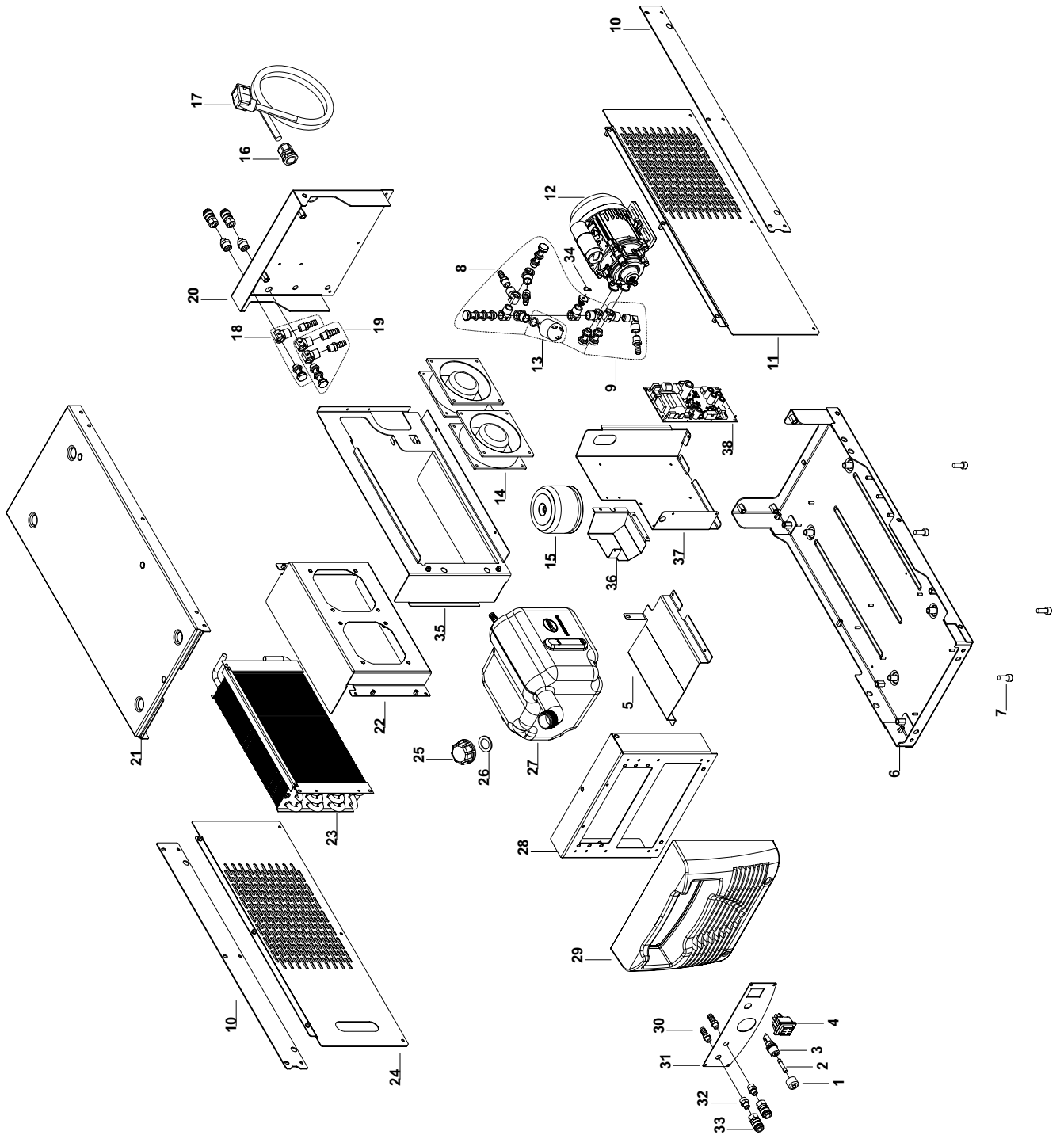

ENGLISH

No.	CODE	DESCRIPTION
1	016.0011.0004	FUSE HOLDER CAP
2	040.0007.1160	FUSE
3	040.0006.1880	FUSE HOLDER
4	040.0001.0003	SWITCH
5	011.0012.0106	TANK FIXING PLATE
6	011.0012.0150	LOWER CASE
7	016.0201.0624	SCREW M8 H=20mm T.C.E.I. Z.B
8	010.0000.0078	PUMP CONNECTION KIT (F)
9	010.0000.0077	PUMP CONNECTION KIT (E)
10	011.0012.0154	CLAMPING PLATE
11	011.0000.1211	RIGHT SIDE COVER
12	003.0004.0006	PUMP
12	003.0004.0040	PUMP (HP VERSION)
13	010.0000.0079	PRESSURE SWITCH KIT (C)
14	003.0002.0020	FAN
15	041.0006.0011	TRANSFORMER
16	045.0000.0014	CABLE CLAMP
17	022.0002.0074	POWER SUPPLY CABLE
18	010.0000.0082	PUMP CONNECTION KIT (G)
19	010.0000.0083	PUMP CONNECTION KIT (H)
20	011.0012.0151	REAR PLATE
21	011.0012.0152	UPPER COVER
22	011.0012.0158	FAN SUPPORT PLATE
23	003.0003.0017	RADIATOR
24	011.0000.1211	LEFT SIDE COVER
25	003.0003.0015	TANK CAP
26	003.0003.0016	GASKET
27	003.0003.0018	TANK
28	011.0012.0101	FRONT PLATE
29	012.0006.0100	FRONT PLASTIC PANEL
30	016.5001.3041	SLEEVE HOSE ADAPTER FOR RUBBER HOSE Ø= 10 mm F= 1/8 M
31	011.0012.0103	CONNECTIONS FRONT PLATE
32	017.0003.0055	F=1/8 - M=1/8 NIPPLE CONNECTOR
33	018.0002.0004	QUICK CLUTCH 1/8 GAS
34	040.0003.1012	THERMIC SENSOR
35	011.0012.0158	RADIATOR SUPPORT PLATE
36	011.0012.0157	SWITCH PROTECTION PLATE
37	011.0012.0156	PROTECTION PLATE
38	050.0002.0150	FAN BOARD

5.4 PRE-ASSEMBLED FITTINGS KIT

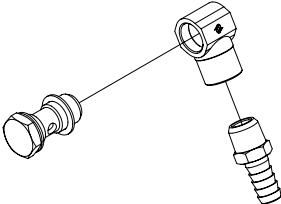
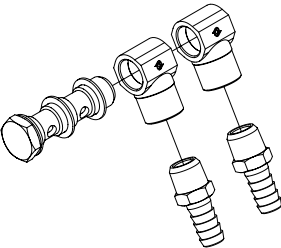
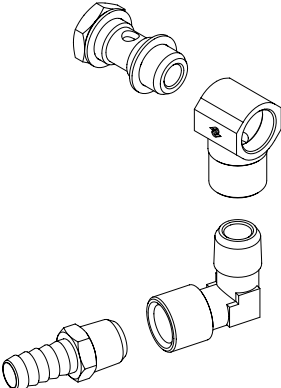
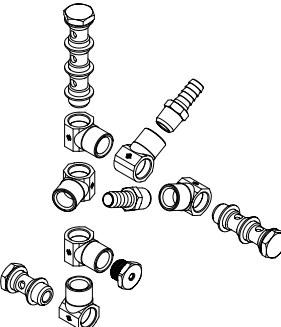
No.	CODE	DESCRIPTION
	010.0000.0082	PUMP FITTING KIT (G)
	010.0000.0083	PUMP FITTING KIT (H)
	010.0000.0077	PUMP FITTING KIT (E)
	010.0000.0078	PUMP FITTING KIT (F)

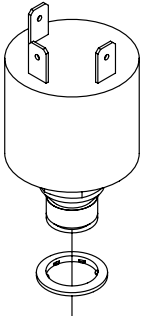
	010.0000.0079	PRESURE SWITCH KIT (C)
---	---------------	------------------------

5.5 COOLING UNIT PUMP (KN37)

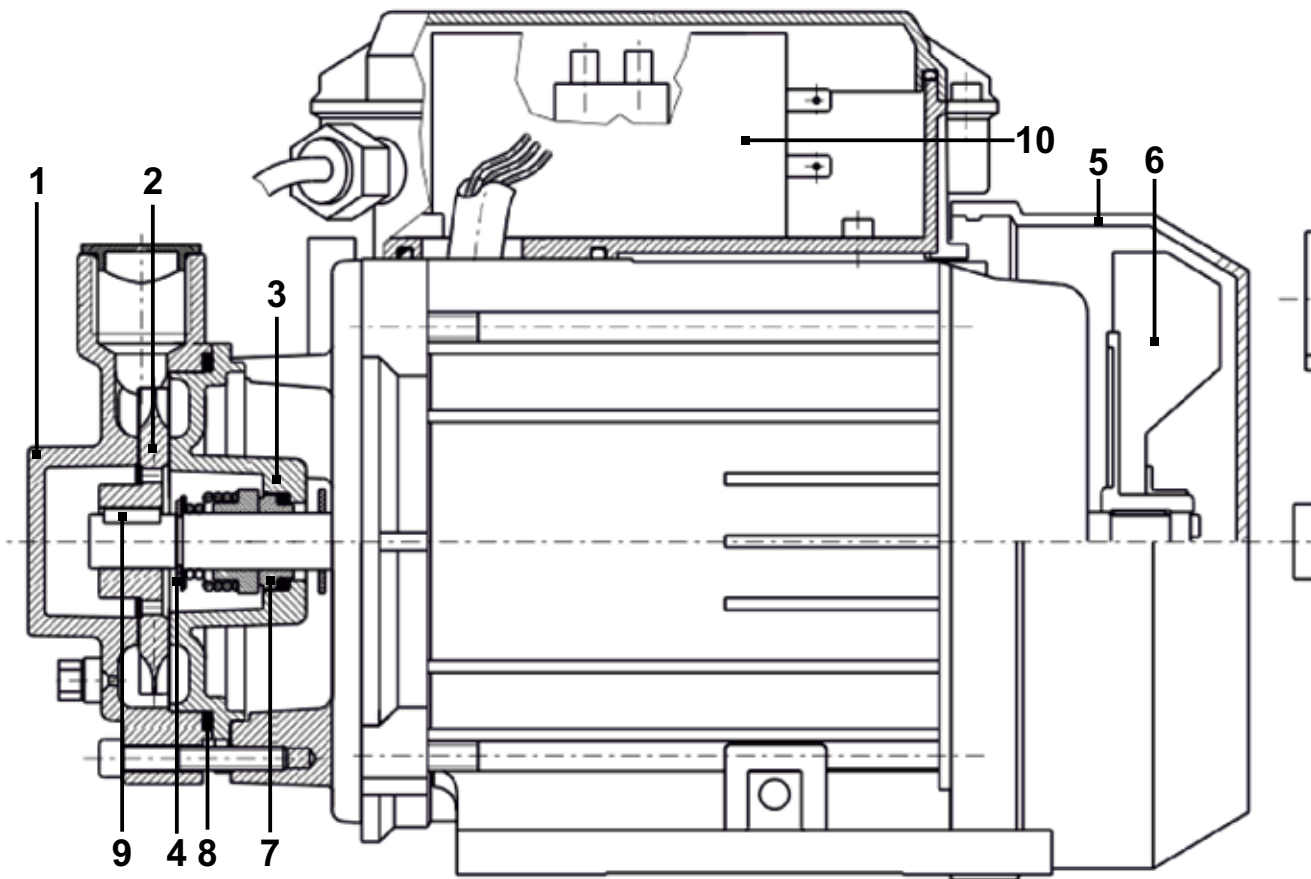

No.	CODE	DESCRIPTION
1	003.0004.0034	PUMP BODY ¼ GAS
2	003.0004.0018	IMPELLER
3	003.0004.0019	SEAL BASE
4	003.0004.0020	SEEGER RING
5	003.0004.0035	COVER
6	003.0004.0036	FAN
7	003.0004.0021	MECHANICAL COMPLETE SEAL
8	003.0004.0023	BODY O-RING
9	003.0004.0022	PUMP SHAFT KEY
10	003.0004.0033	CAPACITOR 6,3uF PUMP KN37





WELD THE WORLD

www.weco.it

