



WELD THE WORLD

Pioneer  
Pioneer Pulse

403MSR  
503MSR

# Instruction manual







WELD THE WORLD

---

## INDEX

<b>1</b>	<b>INTRODUCTION</b> .....	<b>4</b>
1.1	INTRODUCTION.....	5
<b>2</b>	<b>INSTALLATION</b> .....	<b>6</b>
2.1	CONNECTIONS TO THE ELECTRICAL MAINS NETWORK.....	6
2.2	FRONT PANEL.....	6
2.3	REAR PANEL.....	7
<b>3</b>	<b>USER INTERFACE</b> .....	<b>8</b>
<b>4</b>	<b>TECHNICAL DATA</b> .....	<b>8</b>
4.1	PIONEER 503 MSR / PIONEER PULSE 503 MSR .....	9
4.2	PIONEER 403 MSR / PIONEER PULSE 403 MSR .....	10
<b>5</b>	<b>PIONEER 403/503MSR→WF CABLE</b> .....	<b>12</b>
<b>6</b>	<b>ELECTRICAL DIAGRAM</b> .....	<b>13</b>
6.1	PIONEER 403-503MSR / PIONEER PULSE 403-503MSR.....	13
<b>7</b>	<b>SPARE PARTS</b> .....	<b>18</b>
7.1	PIONEER 403-503MSR / PIONEER PULSE 403-503MSR.....	18

## 1 INTRODUCTION

 	<b>IMPORTANT!</b>
<p><i>This handbook must be consigned to the user prior to installation and commissioning of the unit. Read the "General prescriptions for use" handbook supplied separately from this handbook before installing and commissioning the unit.</i></p> <p><i>The meaning of the symbols in this manual and the associated precautionary information are given in the "General prescriptions for use".</i></p> <p><i>If the "General prescriptions for use" are not present, it is mandatory to request a replacement copy from the manufacturer or from your dealer.</i></p> <p><i>Retain these documents for future consultation.</i></p>	

### LEGEND

	<b>DANGER!</b>
<p><i>This pictogram warns of danger of death or serious injury.</i></p>	

	<b>WARNING!</b>
<p><i>This pictogram warns of a risk of injury or damage to property.</i></p>	

	<b>CAUTION!</b>
<p><i>This pictogram warns of a potentially hazardous situation.</i></p>	

	<b>INFORMATION</b>
<p><i>This pictogram gives important information concerning the execution of the relevant operations.</i></p>	

- ➔ This symbol identifies an action that occurs automatically as a result of a previous action.
- ① This symbol identifies additional information or a reference to a different section of the manual containing the associated information.
- § This symbol identifies a reference to a chapter of the manual.
- \*1 The symbol refers to the associated numbered note.

### NOTES

The figures in this manual are purely guideline and the images may contain differences with respect to the actual equipment to which they refer.

## 1.1 INTRODUCTION

PIONEER 403-503MSR is a power source for welding.  
When combined with a wire feeder it can be used for MIG/MAG welding.

**Fan.** The fan is turned on only during welding, at the end of the welding process it remains on for a fixed period of time according to welding conditions.  
The fan is nonetheless controlled by specific thermal sensors that guarantee a correct cooling of the machine.

**Accessories/ancillary devices that can be connected to the unit:**

- Power source trolley for multi-function configuration (MIG/MAG).
- Liquid cooler for MIG/MAG torches.
- Wire feeder.

Consult your dealer for an updated list of accessories and the latest new products available.

## 2 INSTALLATION



### **DANGER!** **Lifting and positioning**

Read the warnings highlighted by the following symbols in the "General prescriptions for use".



### 2.1 CONNECTIONS TO THE ELECTRICAL MAINS NETWORK

The mains power supply features to which the equipment should be connected are given in chapter "TECHNICAL DATA".

The machine can be connected to motorgenerators provided their voltage is stabilised.  
Connect/disconnect the various devices with the machine switched off.

### 2.2 FRONT PANEL

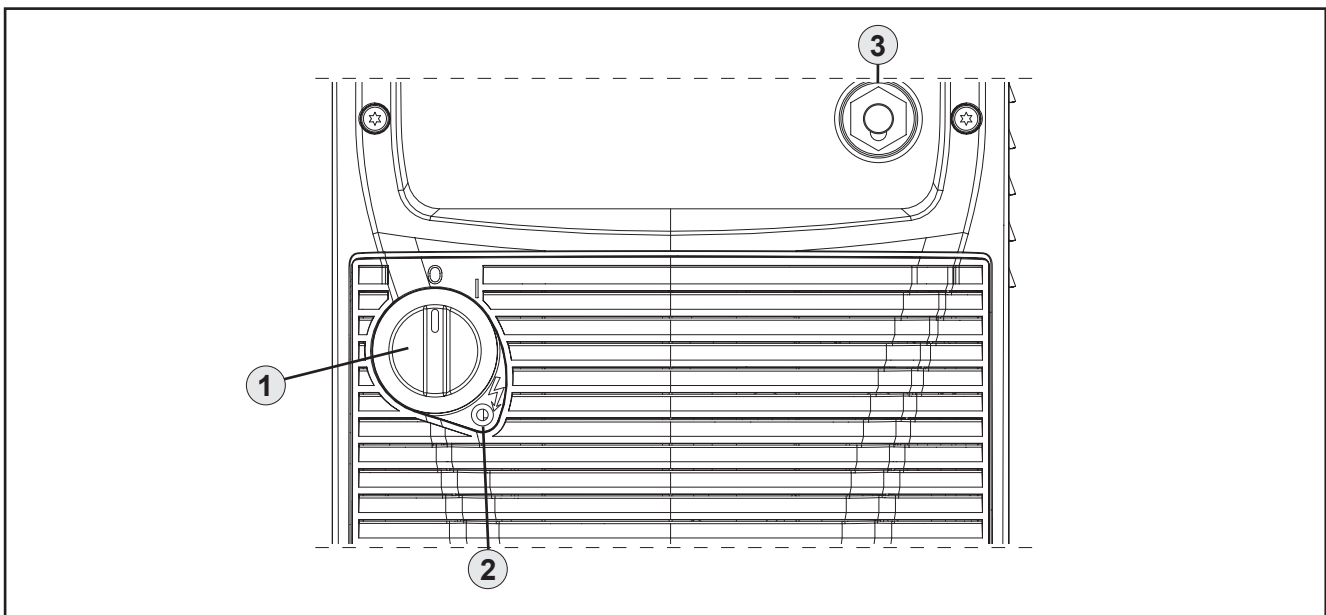

- Welding power source ON/OFF switch. [Item 1].
- Mains protection ON LED [Item 2].
- Earth welding socket [Item 3].

## 2.3 REAR PANEL

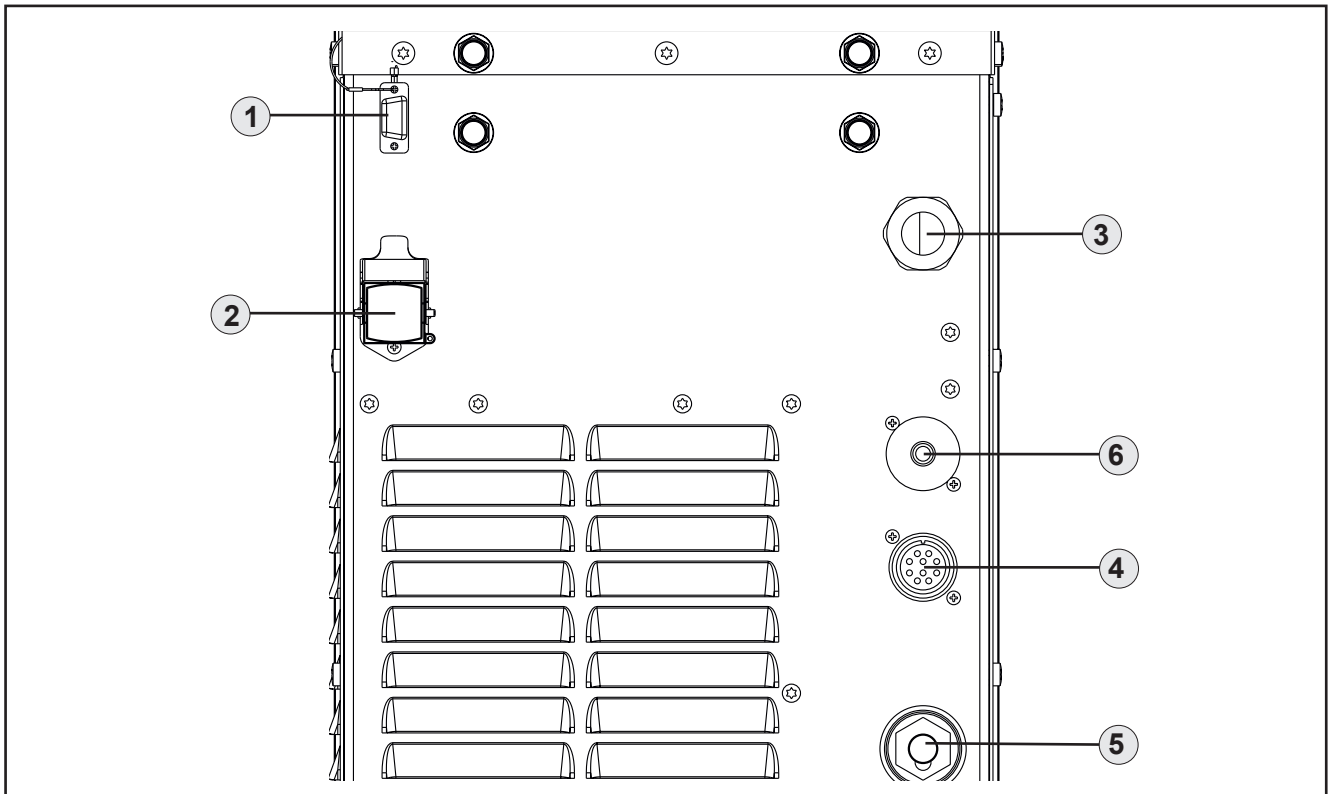

- Connector for connection to the programmer [Item 1]. Programming connector for the “pulsed” circuit board. You can update the software of the equipment using the programming kit.
- Cooler group power feeding connector [Item 2].
  - Voltage: 400 V a.c.
  - Current output: 1.0 A
  - IP protection rating: IP20 (cap open) / IP66 (cap closed)



**DANGER!**  
**High voltage!**

*If the socket is not connected to any devices always close cap*

- Power cable [Item 3].
  - Total length (external part): 4,3 m
  - Number and cross section of wires: 4 x 6 mm<sup>2</sup>
  - Power plug type: not supplied
- Connector of the bundle of cables for connecting the power source to the remote control device [Item 4].
- Socket for connecting the power cable between the power source and the remote control device [Item 5].
- Signals connector for automatic application [Item6].



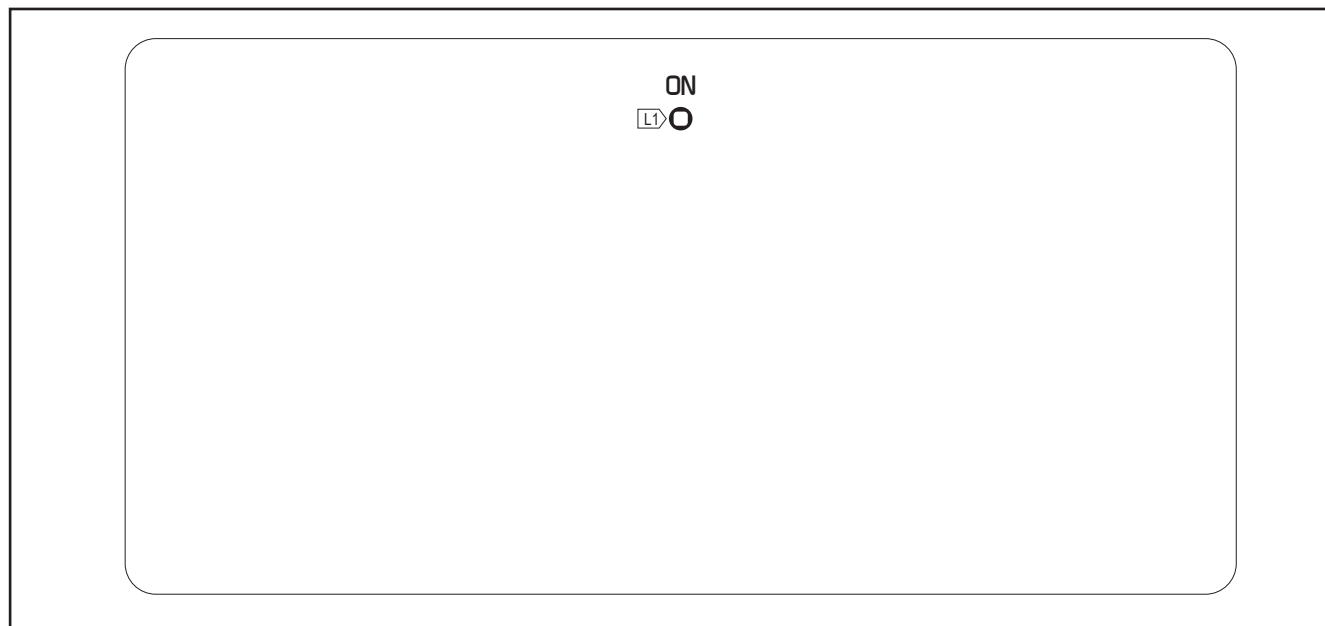

### 3 USER INTERFACE

#### PIONEER 403-503MSR / PIONEER PULSE 403-503MSR





CODE	SYMBOL	DESCRIPTION
L1	<b>ON</b>	This LED illuminates to confirm the presence of power on the output sockets.

### 4 TECHNICAL DATA



<b>Directives applied</b>	Waste electrical and electronic equipment (WEEE)
	Electromagnetic compatibility (EMC)
	Low voltage (LVD)
	Restriction of the use of certain hazardous substances (RoHS)
<b>Construction standards</b>	EN 60974-1; EN 60974-10 Class A
<b>Conformity markings</b>	 Equipment compliant with European directives in force
	 Equipment suitable in an environment with increased hazard of electric shock
	 Equipment compliant with WEEE directive
	 Equipment compliant with RoHS directive



#### 4.1 PIONEER 503 MSR / PIONEER PULSE 503 MSR

<b>Supply voltage</b>	3 x 400 Va.c. ± 15 % / 50-60 Hz			
<b>Mains protection</b>	32 A 500 V Delayed			
<b>Zmax</b>	This equipment complies with IEC 61000-3-12 provided that the maximum permissible system impedance is less than or equal to 21 mΩ at the interface point between the user's supply and the public system. It is the responsibility of the installer or user of the equipment to ensure, by consultation with the distribution network operator if necessary, that the equipment is connected only to a supply with maximum permissible system impedance less than or equal to 21 mΩ.			
<b>Dimensions ( D x W x H )</b>	700 x 300 x 570 (power source)			
<b>Weight</b>	46 kg (power source)			
<b>Insulation class</b>	H			
<b>Protection rating</b>	IP23			
<b>Cooling</b>	AF: Air-over cooling (fan assisted)			
<b>Static characteristic</b>	MMA	 Falling characteristic		
	TIG	 Falling characteristic		
	MIG/MAG	 Flat characteristic		
<b>Welding mode</b>		MIG/MAG	TIG	MMA
<b>Current and voltage adjustment range</b>		10 A / 14.5 V 500 A / 39.0 V	10 A / 10.4 V 500 A / 30.0 V	10 A / 20.4 V 500 A / 40.0 V
<b>Welding current / Working voltage</b>	30% (40° C)	500 A / 39.0 V		500 A / 40.0 V
	35% (40° C)		500 A / 30.0 V	
	60% (40° C)	430 A / 35.5 V	450 A / 28.0 V	430 A / 37.2 V
	100% (40° C)	400 A / 34.0 V	420 A / 26.8 V	400 A / 36.0 V
<b>Maximum input power</b>	30% (40° C)	25.1 kVA - 22.4 kW		25.5 kVA - 22.3 kW
	35% (40° C)		19.3 kVA - 17.2 kW	
	60% (40° C)	19.7 kVA - 17.0 kW	16.2 kVA - 14.0 kW	21.0 kVA - 18.0 kW
	100 % (40° C)	17.7 kVA - 15.2 kW	14.6 kVA - 12.6 kW	19.3 kVA - 16.4 kW
<b>Maximum supply current</b>	30% (40° C)	36.0 A		36.4 A
	35% (40° C)		27.7 A	
	60% (40° C)	27.8 A	22.9 A	30.0 A
	100 % (40° C)	25.5 A	21.1 A	27.8 A
<b>Maximum Effective Supply Current</b>	30% (40° C)	19.7 A		19.9 A
	35% (40° C)		16.4 A	
	60% (40° C)	21.5 A	17.7 A	23.2 A
	100 % (40° C)	25.5 A	21.1 A	27.8 A
<b>No-load voltage (U0)</b>	62V			
<b>Reduced no-load voltage (Ur)</b>	10V			
<b>Power source efficiency</b>	Efficiency (500A / 40,0V): 88,8%			
	No-Load condition power consumption (U1= 400 Va.c.): 27 W			
<b>Essential raw materials</b>	According to the information provided by our suppliers, this product does not contain essential raw materials in quantities greater than 1g per component.			

## 4.2 PIONEER 403 MSR / PIONEER PULSE 403 MSR

<b>Supply voltage</b>	3 x 400 Va.c. $\pm$ 15 % / 50-60 Hz			
<b>Mains protection</b>	25 A 500 V Delayed			
<b>Zmax</b>	This equipment complies with IEC 61000-3-12 provided that the maximum permissible system impedance is less than or equal to 21 m $\Omega$ at the interface point between the user's supply and the public system. It is the responsibility of the installer or user of the equipment to ensure, by consultation with the distribution network operator if necessary, that the equipment is connected only to a supply with maximum permissible system impedance less than or equal to 21 m $\Omega$ .			
<b>Dimensions ( D x W x H )</b>	700 x 300 x 570 (power source)			
<b>Weight</b>	46 kg (power source)			
<b>Insulation class</b>	H			
<b>Protection rating</b>	IP23			
<b>Cooling</b>	AF: Air-over cooling (fan assisted)			
<b>Static characteristic</b>	MMA	 Falling characteristic		
	TIG	 Falling characteristic		
	MIG/MAG	 Flat characteristic		
<b>Welding mode</b>		MIG/MAG	TIG	MMA
<b>Current and voltage adjustment range</b>		10 A / 14.5 V 400 A / 34.0 V	10 A / 10.4 V 400 A / 26.0 V	10 A / 20.4 V 400 A / 36.0 V
<b>Welding current / Working voltage</b>	30% (40° C)	-	-	-
	65% (40° C)	400 A / 34.0 V	-	400 A / 36.0 V
	100% (40° C)	370 A / 32.5 V	400 A / 26.0 V	370 A / 34.8 V
<b>Maximum input power</b>	30% (40° C)	-	-	-
	65% (40° C)	17.7 kVA - 15.2 kW	-	19.3 kVA - 16.4 kW
	100 % (40° C)	15.8 kVA - 13.4 kW	13.7 kVA - 11.6 kW	16.9 kVA - 14.3 kW
<b>Maximum supply current</b>	30% (40° C)	-	-	-
	65% (40° C)	25.5 A	-	27.8 A
	100 % (40° C)	23.0 A	19.9 A	24.6 A
<b>Maximum Effective Supply Current</b>	30% (40° C)	-	-	-
	65% (40° C)	20.6 A	-	22.4 A
	100 % (40° C)	23.0 A	19.9 A	24.6 A
<b>No-load voltage (U0)</b>	62V			
<b>Reduced no-load voltage (Ur)</b>	10V			
<b>Power source efficiency</b>	Efficiency (400A / 36,0V): 89%			
	No-Load condition power consumption (U1= 400 Va.c.): 27 W			
<b>Essential raw materials</b>	According to the information provided by our suppliers, this product does not contain essential raw materials in quantities greater than 1g per component.			



## 5 PIONEER 403/503MSR → WF CABLE

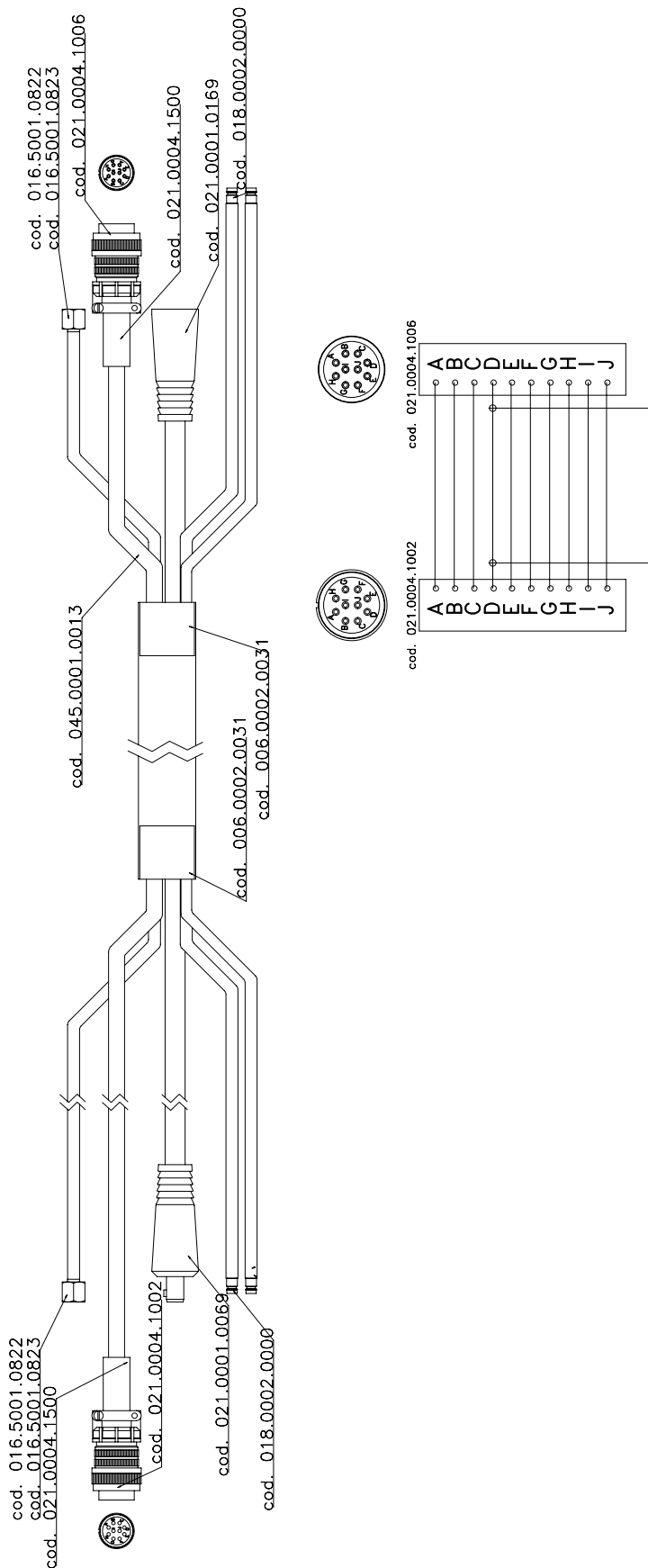

## 6 ELECTRICAL DIAGRAM

### 6.1 PIONEER 403-503MSR / PIONEER PULSE 403-503MSR

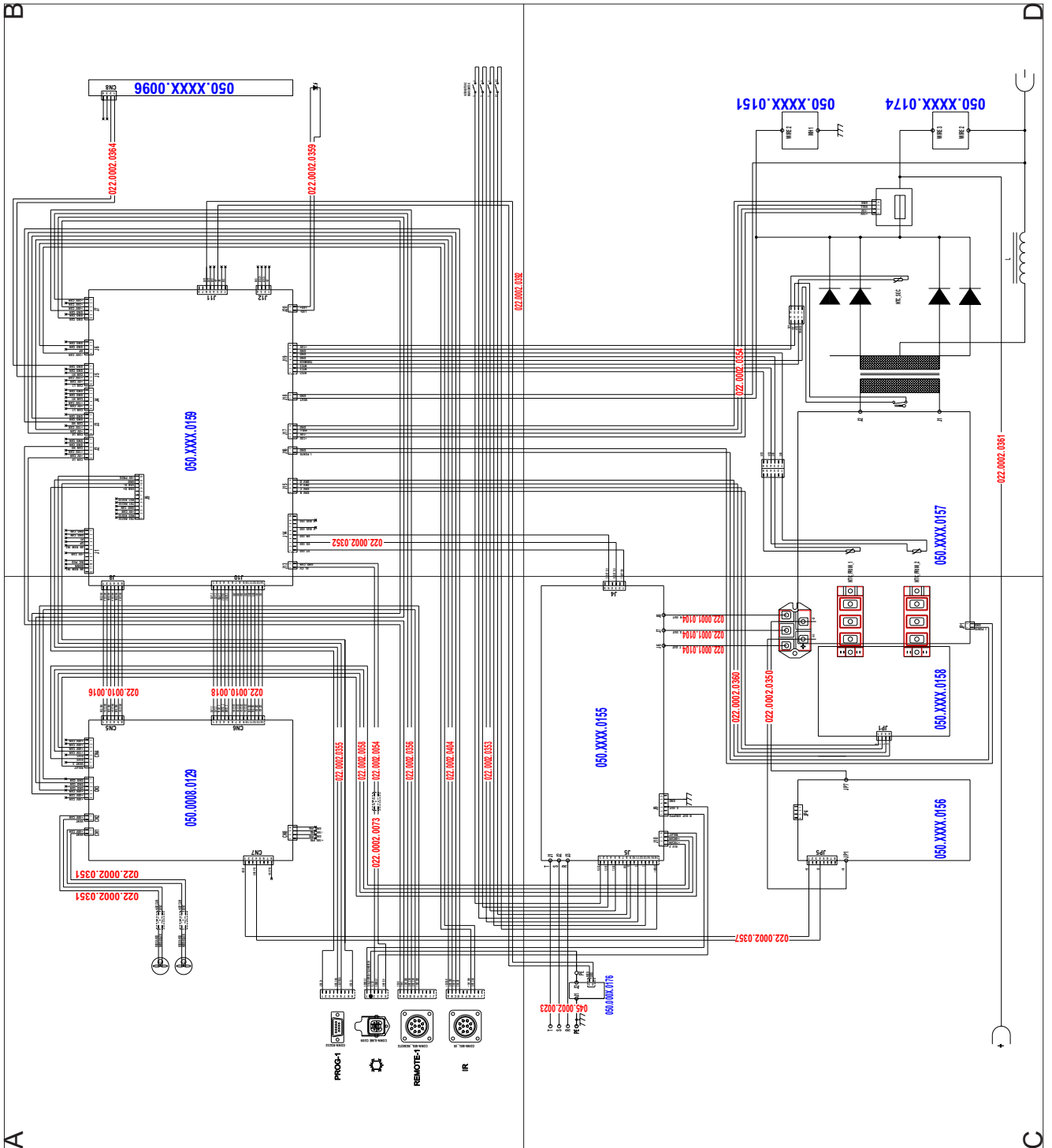



B

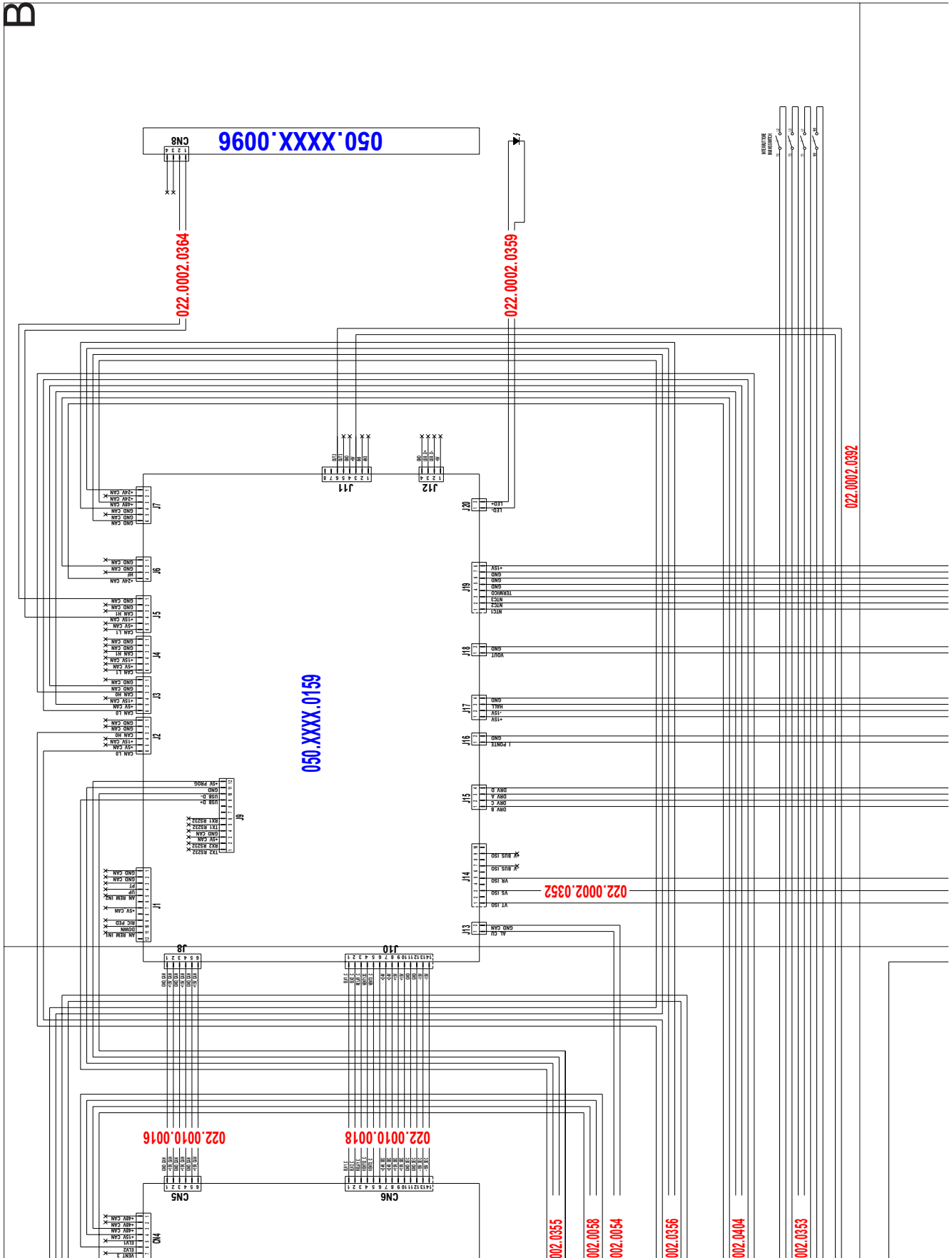

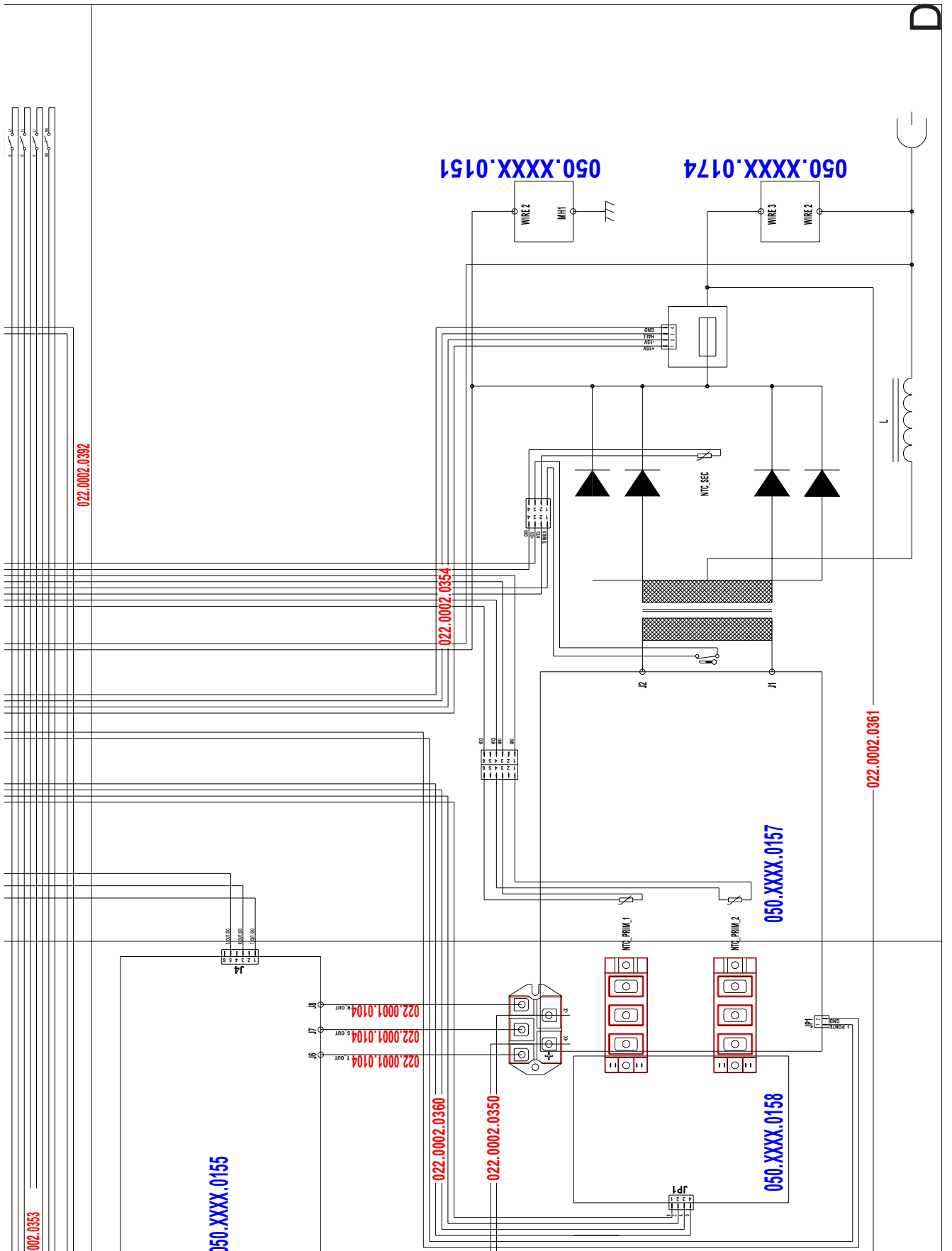



WELD THE WORLD

Pioneer 403MSR/503MSR  
Pioneer Pulse 403MSR/503MSR

ENGLISH

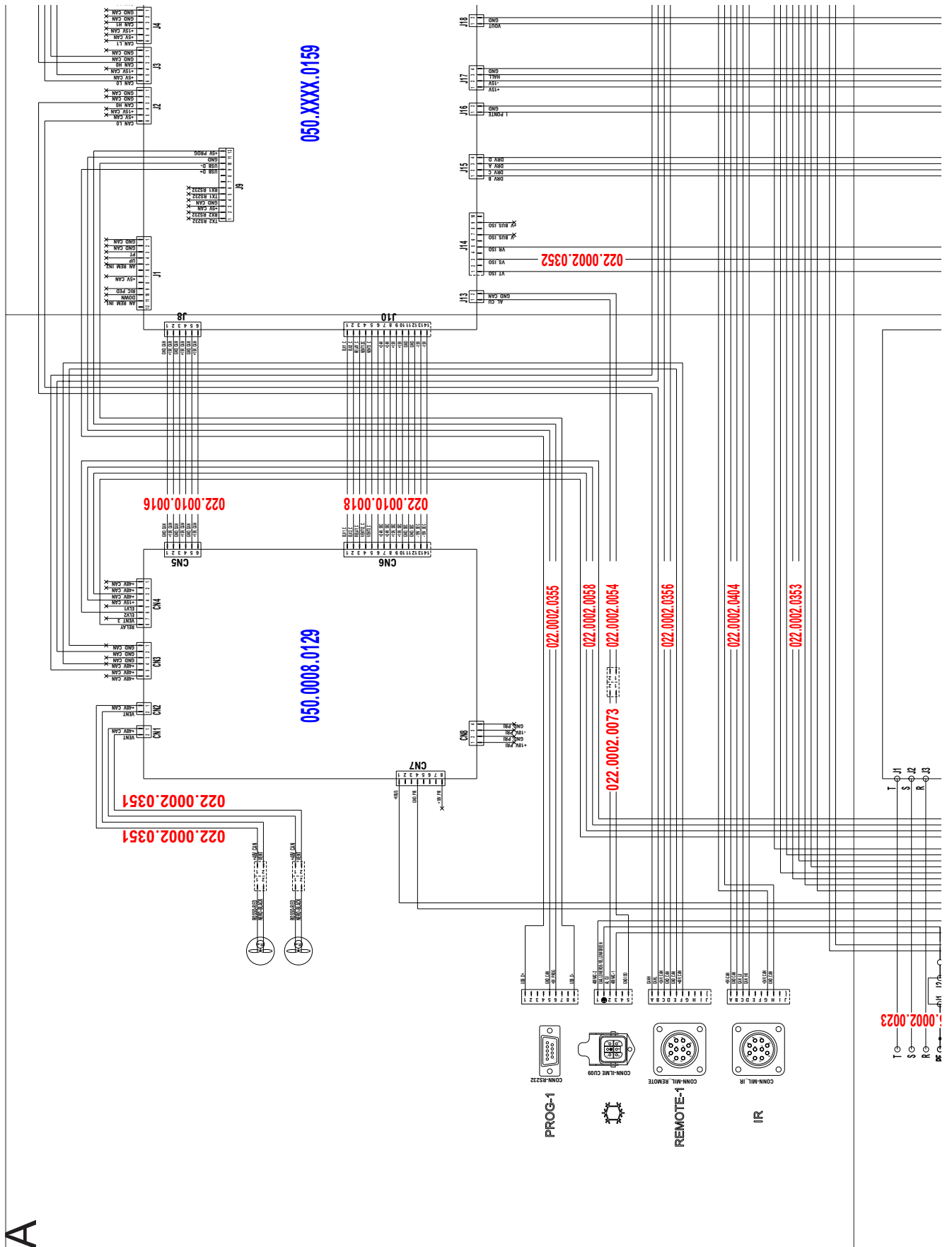

A



Pioneer 403MSR/503MSR  
 Pioneer Pulse 403MSR/503MSR



Cod. 006.0001.2120  
 22/07/2022 V.2.6

ENGLISH

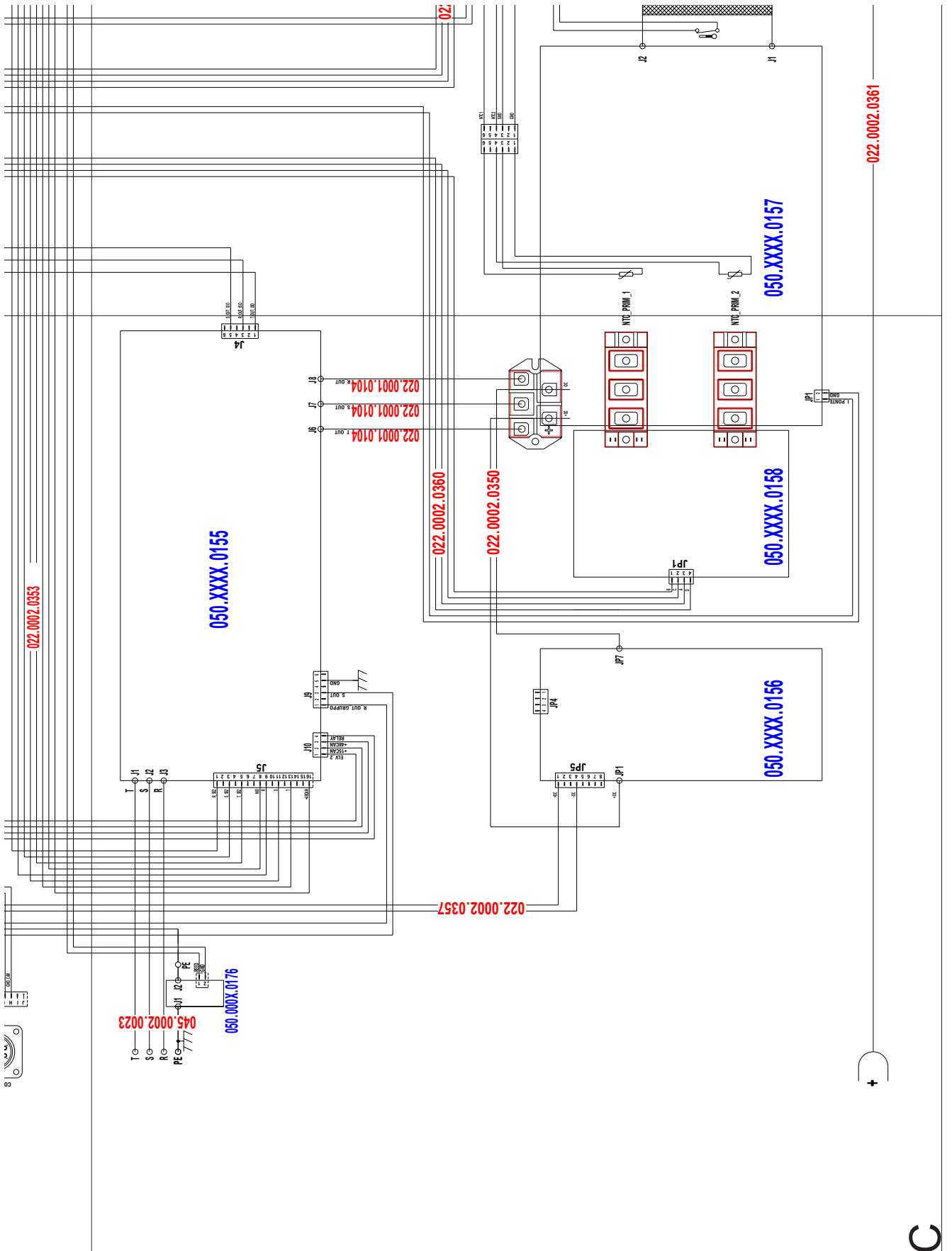

## 7 SPARE PARTS

### 7.1 PIONEER 403-503MSR / PIONEER PULSE 403-503MSR

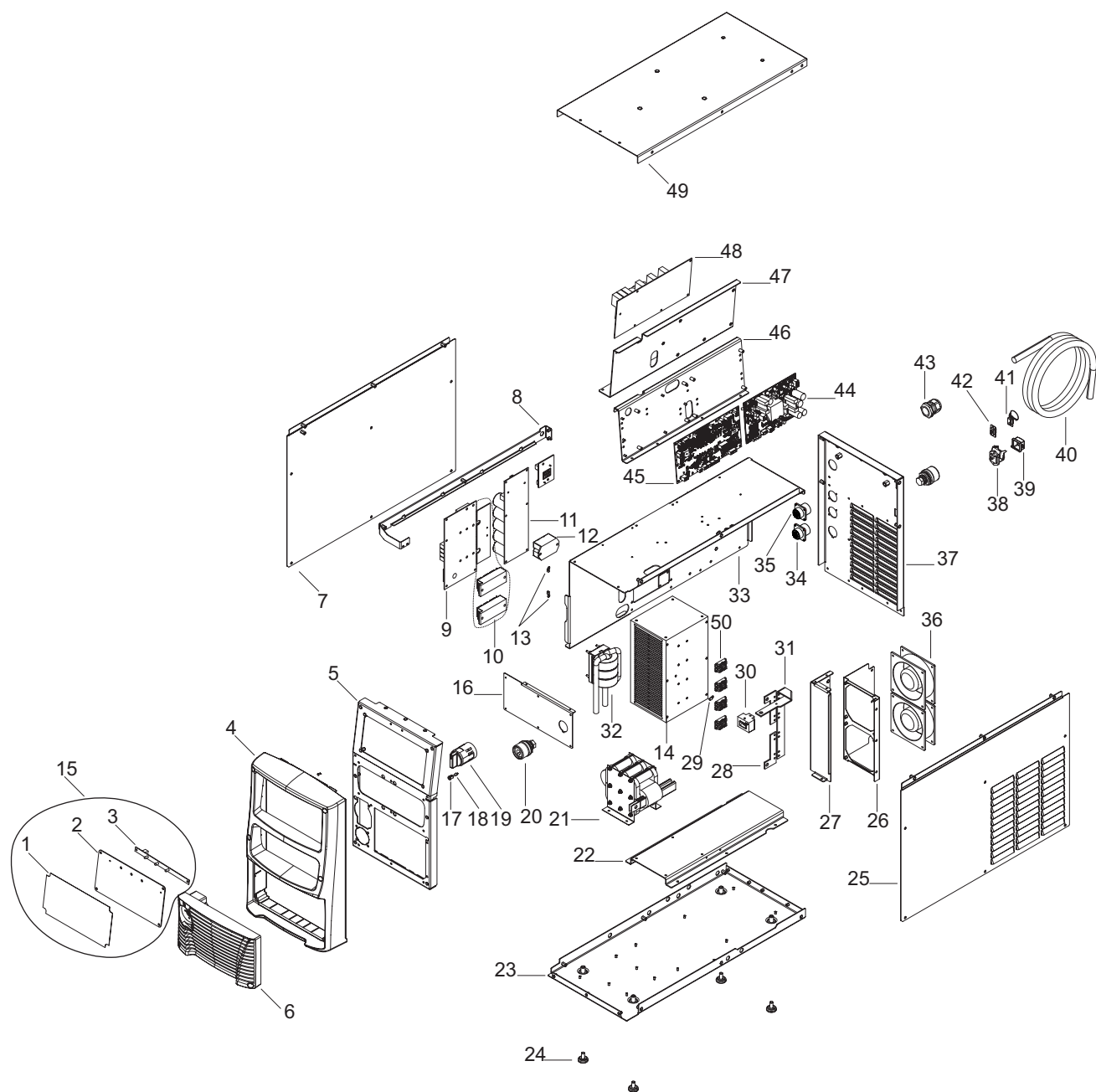

N°	CODE	DESCRIPTION
1	013.0021.1001	FRONT PANEL LABEL (403 MSR)
	013.0021.1101	FRONT PANEL LABEL (503 MSR)
2	013.0000.8044	FRONTAL PANEL PLATE
3	050.0002.0096	LED BOARD
4	012.0007.0010	FRONT PLASTIC
5	011.0013.0021	FRONT PLATE
6	012.0007.0020	PLASTIC LOUVRE
7	011.0000.1171	LEFT COVER
8	011.0013.0258	COVER PANEL SUPPORT PLATE
9	050.0001.0157	PRIMARY BOARD
10	050.0001.0158	DRIVER BOARD + IGBT MODULE
11	050.0001.0156	ELECTROLYTIC CAPACITOR BOARD
12	032.0001.8216	THREE PHASE RECTIFIER BRIDGE
13	040.0003.1011	THERMAL CUT-OUT 2 NTC 10K
14	015.0001.0026	HEAT SINK
15	050.5097.0000	COMPLETE FRONT PANEL (403 MSR)
	050.5098.0000	COMPLETE FRONT PANEL (503 MSR)
16	011.0013.0259	FRONT SOCKETS PANEL
17	016.4107.0001	LED HOLDER
18	022.0002.0364	LED WIRING
19	040.0001.0016	FOUR-POLE SWITCH
20	021.0001.0279	OUTPUT SOCKET
21	042.0003.0053	POWER TRANSFORMER
22	011.0013.0251	HEAT SINK SUPPORT PLATE
23	011.0013.0250	LOWER COVER
24	016.0009.0003	RUBBER FOOT
25	011.0000.1191	RIGHT COVER
26	011.0013.0254	INTERNAL FAN SUPPORT
27	011.0013.0253	SEPARATION PLATE
28	045.0006.0117	DIODES-TRANSFORMER COPPER BRACKET
29	040.0003.1012	THERMAL CUT-OUT NTC 10K
30	041.0004.0502	HALL EFFECT SENSOR
31	045.0006.0116	OUT COPPER BRACKET
32	044.0004.0029	OUTPUT INDUCTOR
33	011.0013.0252	UPPER PLATE
34	022.0002.0356	10 PIN CONNECTOR CABLE
35	022.0002.0404	CABL. REMOTE 403/503 ROBOT
36	003.0002.0017	FAN
37	011.0013.0255	FRONT PLATE
38	022.0002.0073	CU SUPPLY CABLE
39	021.0013.0007	ILME CONNECTOR CAP
40	045.0002.0023	SUPPLY CABLE

N°	CODE	DESCRIPTION
41	021.0014.0303	RS-232 CONNECTOR CAP
42	022.0002.0355	RS-232 WIRING
43	045.0000.0017	CABLE CLAMP
44	050.0008.0129	SUPPLIES BOARD
45	050.0001.0159	CONTROL BOARD (403MSR)
	050.0002.0159	CONTROL BOARD (503MSR)
	050.0006.0159	CONTROL BOARD (403MSR PULSE)
	050.0007.0159	CONTROL BOARD (503MSR PULSE)
46	011.0013.0257	RIGHT SUPPORT BOARD PLATE
47	011.0013.0256	LEFT SUPPORT BOARD PLATE
48	050.0001.0155	MAINS FILTER BOARD
49	011.0013.0260	UPPER COVER
50	032.0002.2403	ISOTOP DIODE
51	050.0001.0176	REED SENSOR BOARD



WELD THE WORLD





**WELD THE WORLD**

[www.weco.it](http://www.weco.it)

