



Discovery
Discovery

220T Evo/VRD Evo
300T Evo/VRD Evo

WELD THE WORLD

Instruction manual







WELD THE WORLD

Discovery 220T Evo/VRD Evo
Discovery 300T Evo/VRD Evo



WELD THE WORLD

1 INTRODUCTION

 	IMPORTANT!
<p><i>This handbook must be consigned to the user prior to installation and commissioning of the unit. Read the "General prescriptions for use" handbook supplied separately from this handbook before installing and commissioning the unit.</i></p> <p><i>The meaning of the symbols in this manual and the associated precautionary information are given in the "General prescriptions for use".</i></p> <p><i>If the "General prescriptions for use" are not present, it is mandatory to request a replacement copy from the manufacturer or from your dealer.</i></p> <p><i>Retain these documents for future consultation.</i></p>	

LEGEND

	DANGER!
<p><i>This pictogram warns of danger of death or serious injury.</i></p>	

	WARNING!
<p><i>This pictogram warns of a risk of injury or damage to property.</i></p>	

	CAUTION!
<p><i>This pictogram warns of a potentially hazardous situation.</i></p>	

	INFORMATION
<p><i>This pictogram gives important information concerning the execution of the relevant operations.</i></p>	

- ⦿ This symbol identifies an action that occurs automatically as a result of a previous action.
- ① This symbol identifies additional information or a reference to a different section of the manual containing the associated information.
- § This symbol identifies a reference to a chapter of the manual.
- *1 The symbol refers to the associated numbered note.

NOTES

The figures in this manual are purely guideline and the images may contain differences with respect to the actual equipment to which they refer.

1.1 INTRODUCTION

Discovery 220T/300T Evo/VRD Evo is an inverter-based welding power source complete with all the functions required for DC TIG and MMA welding with excellent arc characteristics.

The solidity of the components of this unit makes it a reliable working companion for workshop and outdoor applications.

This unit is ideal for maintenance, food industry, hydraulics, oil pipelines and chemical plants.

The parameters preset in the DC TIG pulsed synergic curve simplify welding by regulation exclusively of the current.

The current is adjustable also from the Up-Down torch.

The simply and intuitive interface allows high precision adjustments with 50 storable programs.

The wide range of adjustable pulsed frequency in combination with the complementary parameters (base current and duty cycle) makes it possible to weld in slow and fast pulsed mode.

Accessories/ancillary devices that can be connected to the unit:

- manual remote control for remote adjustment of the welding current.
- foot-pedal remote control for TIG torch arc striking and remote adjustment of welding current.
- UP/DOWN torch or torch with potentiometer.
- liquid cooler for TIG torches.

Consult your dealer for an updated list of accessories and the latest new products available.

2 INSTALLATION



DANGER! **Lifting and positioning**

Read the warnings highlighted by the following symbols in the “General prescriptions for use”.

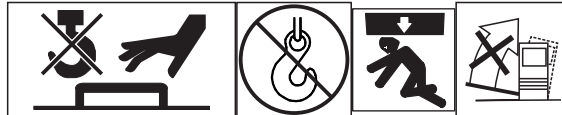

2.1 CONNECTIONS TO THE ELECTRICAL MAINS NETWORK

The mains power supply features to which the equipment should be connected are given in chapter “12 TECHNICAL DATA” at page 57.

The machine can be connected to motorgenerators provided their voltage is stabilised.
Connect/disconnect the various devices with the machine switched off.

2.2 FRONT PANEL

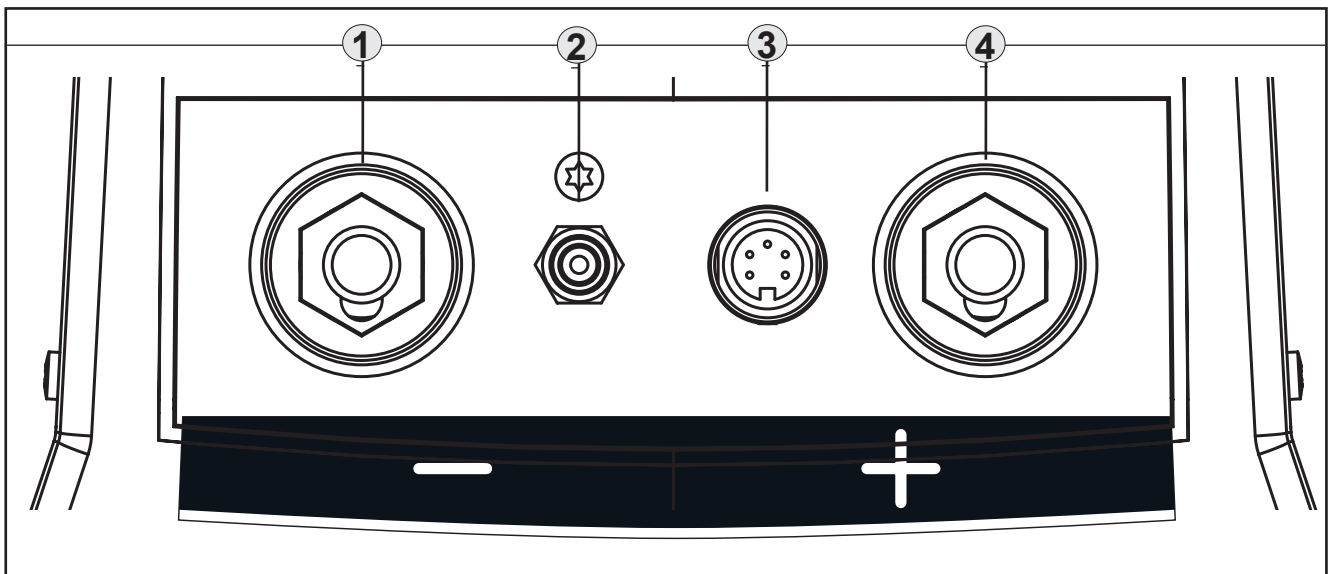

- Negative pole welding socket. [Item 1].
- Connector for gas feed hose: gas flow from the power source to the torch. [Item 2].
- TIG TORCH control connector [Item 3].
- Positive pole welding socket. [Item 4].

2.3 REAR PANEL

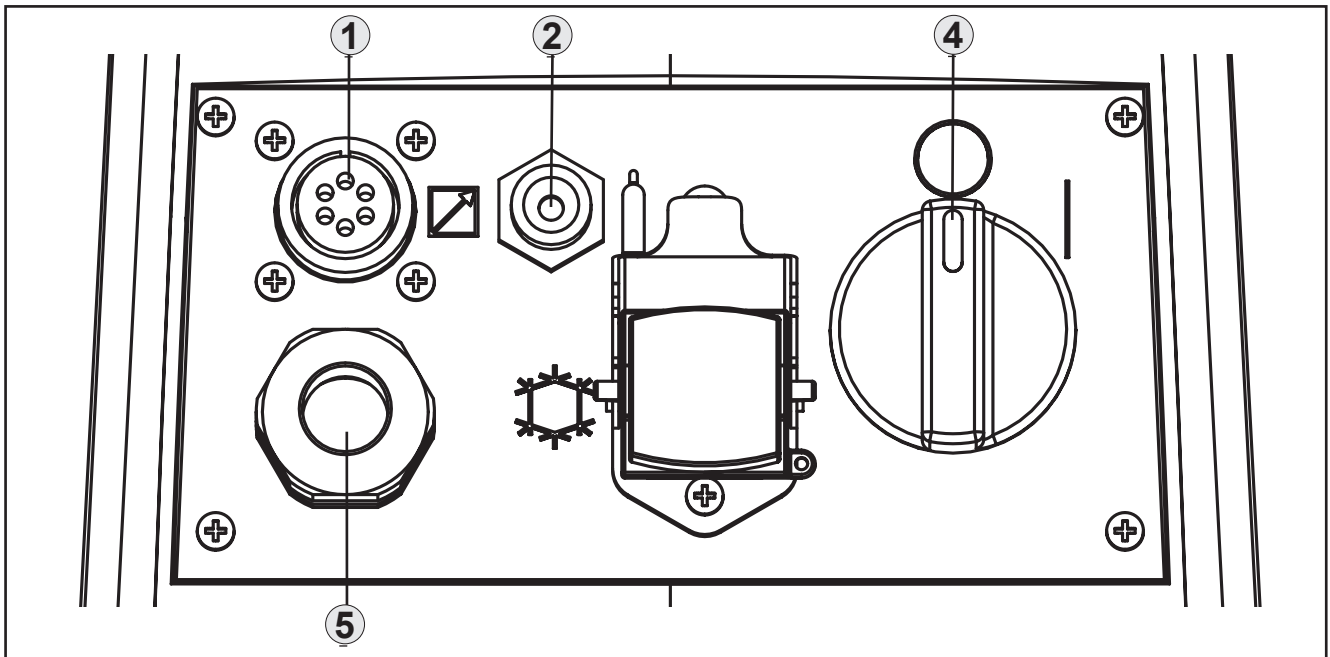

- Remote control connector [Item 1].
- Connector for gas feed hose: gas flow from the cylinder to the power source [Item 2].
- Cooling unit power feeding connector [Item 3].
 - Voltage: 230 V a.c.
 - Current output: 1.35 A
 - IP protection rating: IP20 (cap open) / IP66 (cap closed)



DANGER!
High voltage!

If the socket is not connected to any devices always close the cap

- Welding power source ON/OFF switch [Item 4].
- Power cable. [Item 5].
 - Length (outer side): 2,05 m
 - Number and cross section of wires: 3 x 2.5 mm² (on 220T Evo/VRD Evo) / 4 x 2.5 mm² (on 300T Evo/VRD Evo)
 - Power plug type: Schuko 250 V a.c. / 16 A (on 220T Evo/VRD Evo) / not supplied (on 300T Evo/VRD Evo)

2.4 PREPARING FOR MMA WELDING

1. Set the welding power source ON/OFF switch to “O” (unit switched off).
2. Plug the power cable plug into a mains socket outlet.
3. Choose the electrode based on the type of material and thickness of the workpiece to be welded.
4. Insert the electrode in the electrode holder.
5. Connect the electrode holder cable to the welding socket based on the polarity requested by the type of electrode used.
6. Connect the plug of the ground clamp to the welding socket on the basis of the polarity required.
7. Connect the earth clamp to the workpiece being processed.



DANGER!

Electric shock hazard!

Read the warnings highlighted by the following symbols in the “General prescriptions for use”.



8. Set the welding power source ON/OFF switch to “I” (unit powered).
 9. Select the following welding mode on the user interface: MMA
 10. Set the required welding parameter values on the user interface.
- 🔘 When the remote controller [RC] is connected and the relative locking screw is tightened, welding current can be adjusted using the remote controller.
- The system is ready to start welding.

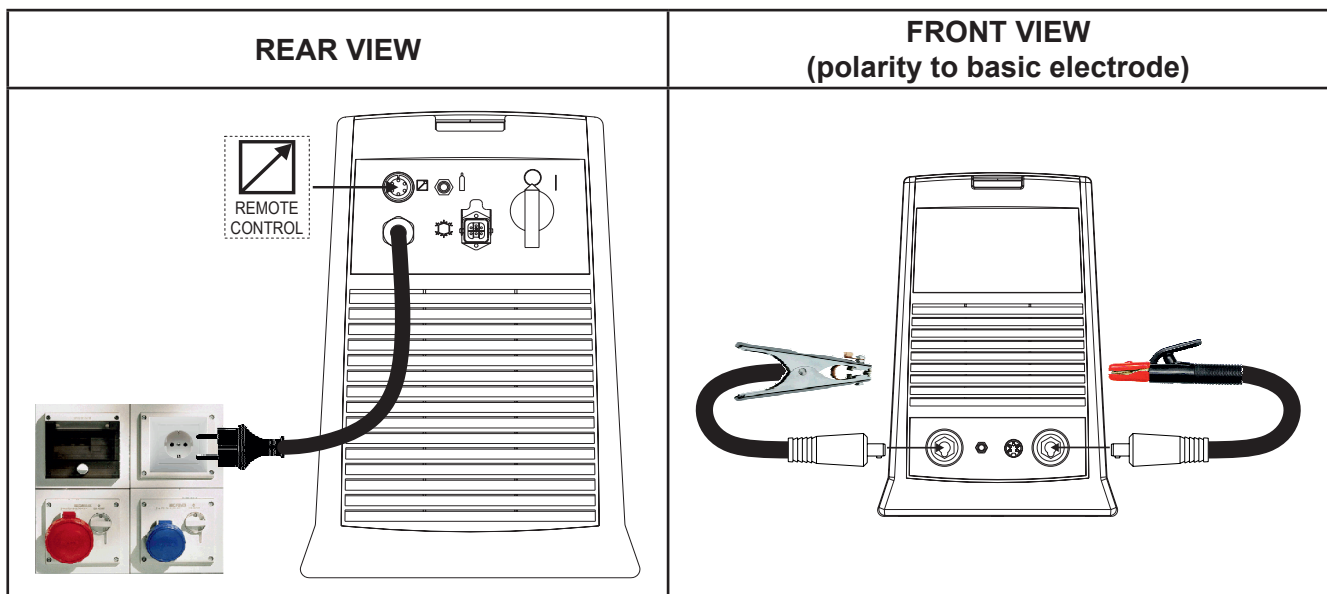

2.5 PREPARING FOR TIG WELDING

NOTE: For the cooler to power source assembly procedure refer to the cooler instruction manual.



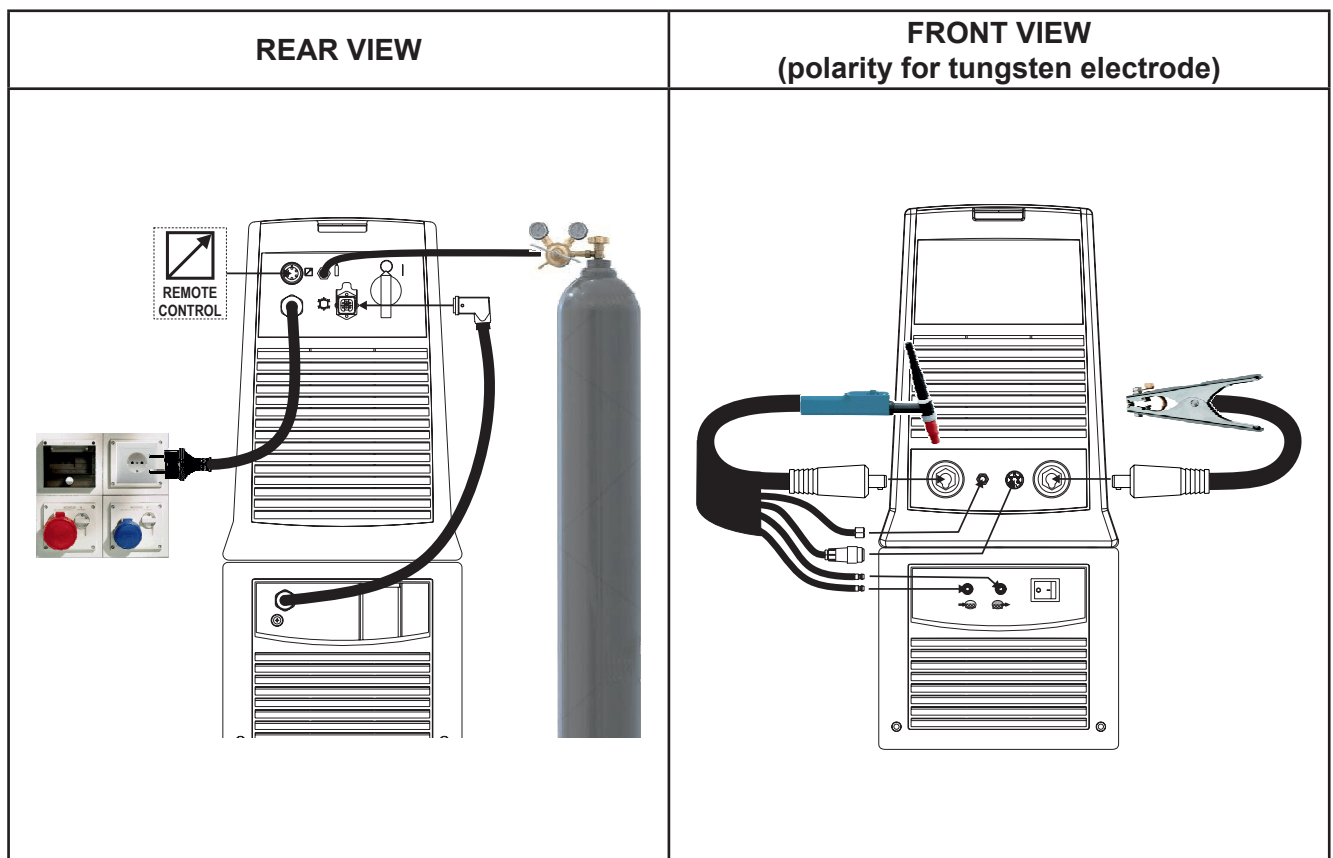



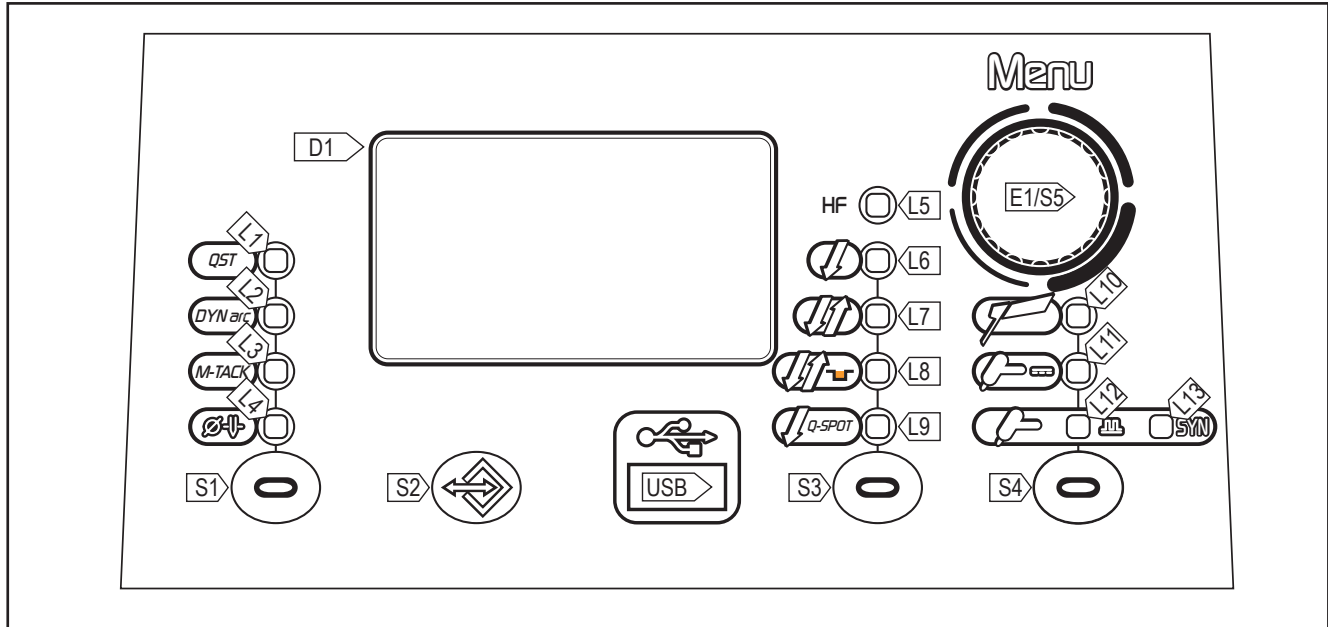

1. Set the welding power source ON/OFF switch to "O" (unit de-energized).
 2. Plug the power cable plug into a mains socket outlet.
 3. Connect the gas hose from the welding gas cylinder to the rear gas socket.
 4. Open the cylinder gas valve.
 5. Choose the electrode based on the type of material and thickness of the workpiece to be welded.
 6. Insert the electrode in the TIG torch.
 7. Connect the torch plug to the welding socket on the basis of the polarity required by the type of electrode in question.
 8. Connect the plug of the ground clamp to the welding socket on the basis of the polarity required.
 9. Connect the gas hose from the welding torch to the front gas socket.
 10. Connect the welding torch connector to the TIG torch signals connector.
 11. Connect the earth clamp to the workpiece being processed.
 12. Set the welding power source ON/OFF switch to "I" (unit powered).
 13. Select the following welding mode on the user interface: DC TIG
 14. Press the torch trigger with the torch well clear of any metal parts. This serves to open the gas solenoid valve without striking the welding arc.
 15. Use the flow control valve to adjust the flow of gas as required while the gas is flowing out.
 16. Set the required welding parameter values on the user interface.
- ⚠ When the remote control pedal is connected and the relative locking screw is tightened the welding current will vary in relation to the pressure exerted on the pedal.
- The system is ready to start welding.









3 USER INTERFACE

Discovery 220T Evo/VRD Evo - Discovery 300T Evo/VRD Evo



CODE	SYMBOL	DESCRIPTION
L1	<i>QST</i>	DC TIG mode: illumination shows that the following parameter can be set: Q-START
L2	<i>DYN arc</i>	DC TIG mode: illumination shows that the following parameter can be set: DYNAMIC ARC
L3	<i>M-TACK</i>	DC TIG mode: illumination shows that the following parameter can be set: MULTI TACK
L4		DC TIG mode: illumination shows that the following parameter can be set: ELECTRODE DIAMETER (mm)
L5	HF	Illumination shows that the following function has been activated: HIGH FREQUENCY ARC STRIKE (HF)
L6		Illumination shows that the following function has been activated: 2 stroke procedure.
L7		Illumination shows that the following function has been activated: 4 stroke procedure.
L8		Illumination shows that the following function has been activated: 4 stroke B-level procedure
L9		Illumination shows that the following function has been activated: 2 stroke spot procedure (Q-SPOT).
L10		This LED illuminates to show that the following welding mode is selected: MMA
L11		This LED illuminates to show that the following welding mode is selected: CONTINUOUS DC TIG
L12		This LED illuminates to show that the following welding mode is selected: PULSED DC TIG
L13	SYN	This LED illuminates to show that the following welding mode is selected: SYNERGIC PULSED DC TIG When this is on, it means that the synergic mode is active and that the operator can set just the welding current while the other parameters are automatically regulated by the machine. The synergy is optimised for angle welding.

CODE	SYMBOL	DESCRIPTION
S1		DC TIG mode: Press the button to select the DC TIG special functions. Possible choices: Q-START - DYNAMIC ARC - MULTI TACK - ELECTRODE DIAMETER
S2		Press the button to access the JOB MENU.
S3		DC TIG mode: This button selects the torch trigger procedure.
S4		This button selects the welding mode.
E1/S5		-Keep the button pressed while powering on the power source: the button opens the SET-UP menu. -Press and release: the button selects the first level menu parameters. -Hold down for 3 seconds: the button opens the second level menu. When in the menu, press and release the button to select the parameters. -Data setting: The encoder sets the value of the selected parameter. -During the welding operations: The encoder sets the value of the following parameter: WELDING CURRENT
USB		Port provided to connect a USB memory stick to export/import JOBs.
D1		IData setting: The display shows the parameter to be set, its value and the graphic symbol associated to it. Welding: The display shows the effective amperes value during welding.

4 UNIT POWER-UP

Set the welding power source ON/OFF switch to “I” to switch on the unit.

The message appears on the following display: **D1**.

FX.X = software version

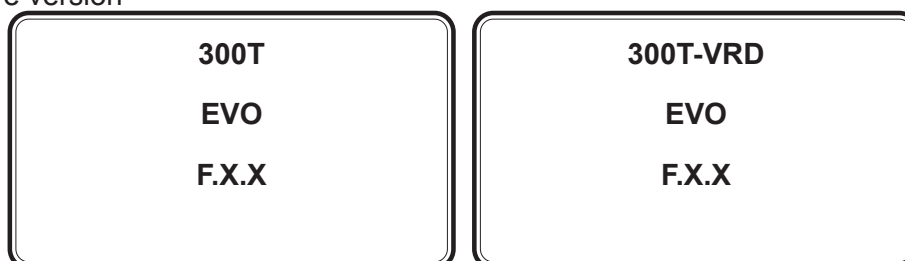

First power-up or power-ups following a RESET procedure

The welding power source sets up for welding with the factory pre-sets.

Subsequent power-ups

The welding power source sets up for welding in the latest stable welding configuration that was active at the time of power-off.

5 RESET (LOAD FACTORY SETTINGS)

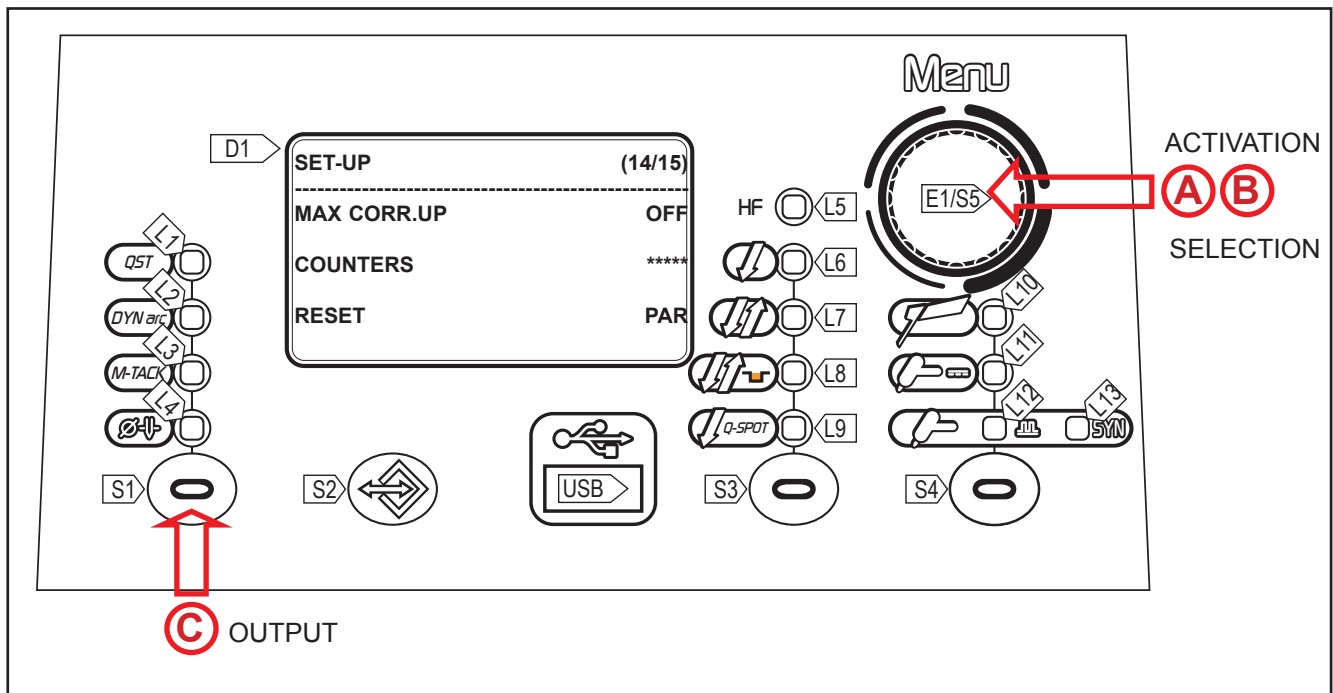

The reset procedure involves complete restoration of the default values, parameters and memory settings set in the factory.

The reset procedure is useful in the following cases:

- Too many changes made to the welding parameters so user finds it difficult to restore defaults.
- Unidentified software problems that prevent the welding power source from functioning correctly.

PARTIAL RESET



The reset procedure involves restoration of the parameter values and settings, except the following settings:









- Settings of the SETUP menu.
- Saved JOBS.

TOTAL RESET

The reset procedure involves complete restoration of the default values, parameters and memory settings set in the factory.





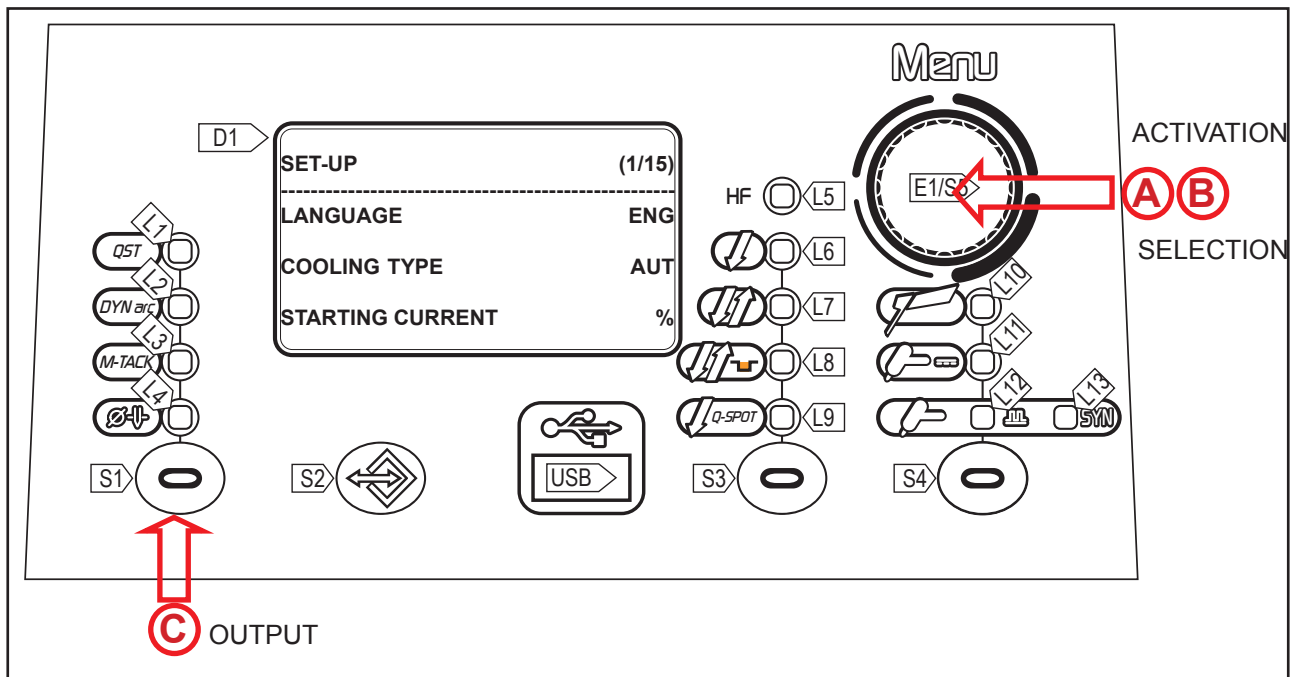

All memory locations will be reset and hence all your personal welding settings will be lost!

(A)	<ul style="list-style-type: none"> o Set the welding power source ON/OFF switch to "O" to switch the unit off. o Holding the S5 button  down, turn the power source switch to "I" to start the unit [ SIMULTANEOUS ACTIONS]. o Display D1 shows the SET-UP MENU.
------------	---------------------------------------------------------------------------------------------------------------------------------------------------------------------------------------------------------------------------------------------------------------------------------------------------------------------------------------------------------------------------------------------------------------------------------------------------------------------------------------------------------

<p>B</p>	<ul style="list-style-type: none">○ Select with encoder E1  the following setting: RESET.○ Press the S5 button .○ Select with encoder E1  the following setting: PAR (partial) o TOT (total).○ Press the S5 button . A message requesting to confirm is displayed.
<p>C</p>	<ul style="list-style-type: none">○ Exit with confirmation<ul style="list-style-type: none">- Press the S5 button .- Wait for the memory clear procedure to terminate.- Press the S1 button  to exit the SET-UP menu.○ Exit without confirmation<ul style="list-style-type: none">- Press the S1 button .- Press the S1 button  to exit the SET-UP menu.

6 SET UP (INITIAL SET-UP OF THE WELDING POWER SOURCE)



- | | |
|----------|--------------------------------------------------------------------------------------------------------------------------------------------------------------------------------------------------------------------------------------------------------------------------------------------------------------------------------------------------------------------------------------------------------------------------------------------------------------------------------------------------------------------------------------------------------------------------------------------------------------------------------------------------------------------------------------------|
| A | <ul style="list-style-type: none"> Set the welding power source ON/OFF switch to “O” to switch the unit off. Holding the S5 button  down, turn the power source switch to “I” to start the unit [ SIMULTANEOUS ACTIONS]. Display D1 shows the MENU SET-UP. |
| B | <ul style="list-style-type: none"> Select with encoder E1  the setting to be edited. Press the S5 button  to confirm. Using the E1 , edit the value of the selected setting. The value is saved automatically. Press the S5 button . It returns to the list of settings. |
| C | <ul style="list-style-type: none"> Exit with confirmation <ul style="list-style-type: none"> Press the S1 button . |

Tab. 1 - Impostazioni di Setup

IMPOSTAZIONE	MIN	DEFAULT	MAX	NOTE
LANGUAGE		EN		ENGLISH ITALIANO FRANÇAIS DEUTSCH ESPAÑOL PORTUGUES DUTCH CESKY SRBSKI POLSKI SUOMI
COOLING TYPE	ON	AUT	OFF	
STARTING CURRENT	%	%	A	
FINAL CURRENT	%	%	A	
HF CURRENT	20 A	SYN	200 A	
HF TIME	0.5 s	2.0 s	3.0 s	
PULSED TYPE	SLOW	FAST	FAST	
PILOT ARC	OFF	ON	ON	
ENABLE READ I.	OFF	ON	ON	
TORCH TYPE	1	1	2	
PEDAL TYPE	2	2	9	
MAX CURR. UP				
COUNTERS				
RESET	PAR	TOT	TOT	
SERVICE	VAL	VAL	CAL	

ER ACTIVATION GROUP

- ON= The cooler is always running when the power source is switched on. This mode is preferable for heavy duty and automatic welding procedures.
- OFF= The cooler is always disabled because an air-cooled torch is in use.
- AUT= When the unit is switched on the cooler is switched on for 15s. During welding procedures the cooler runs constantly. When welding is terminated the cooler continues to run for 90s + a number of seconds equivalent to the average current value shown using the HOLD function.

Torch loading

	WARNING!
<p><i>Make sure the torch in use is correctly sized in relation to the welding current required and for the available and selected cooling type. This prevents the risk of burns to which the operator is potentially exposed, potential faults, and irreversible damage to the torch and the system.</i></p> <p><i>If a torch is installed or replaced while the unit is running, the circuit of the newly installed torch must be filled with coolant to avoid the risk of damage to the torch in the case of high voltage arc strikes without any liquid in the circuit.</i></p>	

Power-up with operation of the cooler set to “ON” or “AUT” mode

- A check is performed automatically of the presence of liquid in the cooling circuit and the cooler is switched on for 15 seconds.
- If the coolant circuit is full, the power source sets up in the most recent stable welding configuration.
- If the coolant circuit is not full, all functions are inhibited and there will be no output power present.

UNIT ALARM! : The message will appear on display D1

Press the (generic) button  to repeat the checking procedure for an additional 15 seconds.
If the problem persists, rectify the cause of the alarm.

Power-up with operation of the cooler set to “OFF”

Operation of the cooler and the cooler alarm are disabled.

Welding is performed without liquid cooling of the torch.

Torch change-over with operation of the cooler set to “ON”

Press and release the torch trigger.

This serves to start the cooler for 15 seconds to fill the torch cooling circuit.

- STARTING CURRENT

- The value of this parameter can be set as a percentage of the welding current or as an absolute value expressed in Amperes.

- FINAL CURRENT

- The value of this parameter can be set as a percentage of the welding current or as an absolute value expressed in Amperes.

- HF CURRENT

- This parameter establishes the current value during HF discharge. The value of this parameter can be set as an absolute value or in SYN.
- With SYN setting the HF current value is calculated automatically on the basis of the pre-set welding current value.

Consequences of a higher value:

- Arc striking is facilitated, even on very dirty workpieces.
- Risk of piercing excessively thin gauge workpieces.

- HF TIME

- This parameter defines the maximum high frequency (HF) arc strike duration.

- PULSED TYPE

- SLOW = This setting enables slow pulsed mode. The peak time and base time are set.
- FAST = This setting enables fast pulsed mode. The frequency and duty-cycle are set.

- PILOT ARC

- The function enables the output of a low current between the 1st and 2nd times of the torch trigger to shield the mask in advance and avoid the risk of blinding flashback caused by the welding current.

- ENABLE READ CURRENT

- This function allows for the real welding current display to be enabled or disabled.

- TORCH TYPE

The parameter changes the torch trigger operating mode.

- oFF: indicates standard operation.
- 1: specifies the 4T B-level management variant. Allows the transition to the secondary welding current by pressing and holding down the UP or DOWN button; when the button is released, the primary current is restored. With variant oFF selected, the UP/DOWN buttons are disabled for all procedures.
- 2: specifies the down slope management variant. By releasing the torch trigger during the third stroke (3S) the down slope is stopped and the final current is immediately delivered without having to go through the entire slope time. The HF restart during the down slope is disabled.

- PEDAL TYPE

- The parameter selects the type of pedal used:
 - RC02 standard pedal type
 - RC09 special pedal type. This type of pedal recognises the pressure applied to the foot pedal or the torch button, switching automatically from internal adjustment to external control using the pedal.

- MAX CURR. UP

When the parameter is set to ON, the maximum value of the welding current that can be set with the UP / DOWN torch is the current set by the encoder in the front panel of the welding power source. When the parameter is set to OFF, the maximum value of the welding current that can be set with the UP / DOWN torch is the maximum current that can be supplied by the welding power source.

- OPERATING HOUR COUNTER

- The menu page shows the processing hour counters.
 - POWER ON = Total number of hours while the machine has been on (mains powered).
 - T.ARC ON = Total number of hours with welding arc on.
 - P.ARC ON = Partial number of hours with welding arc on. Keep the S5 button pressed for 3 seconds to reset the partial P.ARC ON.

SET UP	
POWER ON	7.2 h
T. ARC. ON	5.3 h
P. ARC ON	0.7 h

← The reading is carried out as follows: 7 hours and (0.2x60) 12 minutes

- RESET

- The reset procedure involves complete restoration of the default values, parameters and memory settings set in the factory.
- The reset procedure is useful in the following cases:
 - Too many changes made to the welding parameters so user finds it difficult to restore defaults.
 - Unidentified software problems that prevent the welding power source from functioning correctly.

PARTIAL RESET

- The reset procedure involves restoration of the parameter values and settings, except the following settings:
 - Settings of the SETUP menu.
 - Saved JOBS

TOTAL RESET

- The reset procedure involves complete restoration of the default values, parameters and memory settings set in the factory.
- All memory locations will be reset and hence all your personal welding settings will be lost!

- SERVICE

- his setting enables the machine validation (VAL.) and calibration (CAL) operations.

VALIDATION

- The validation procedure allows the welding current value (Ampere) and voltage value (Volt) to be correctly detected and displayed on the equipment display. The validation procedure requires the equipment to be connected to a suitable static load.

CALIBRATION

- he calibration procedure allows the machine current to be calibrated.

The SERVICE procedure is not described in this manual as it can be carried out only by specialised, suitably trained and equipped technical staff.

The testing methods and the equipment required are set out in the relevant technical standards.

.

7 ALARM MANAGEMENT



This symbol is shown if an incorrect operating condition occurs.
An alarm message appears on the following display: **D1**.

Tab. 2 - Alarm messages

MESSAGE	MEANING	EVENT	CHECKS
E33 T E R M I C ALARM	<p>Overheating alarm Indicates tripping of the welding power source thermal protection. Leave the unit running so that the overheated components cool as rapidly as possible. When the unit has cooled, the welding power source will reset automatically.</p>	<p>All functions disabled. <u>Exceptions:</u></p> <ul style="list-style-type: none"> • Cooling fan. • Cooler (if switched on). 	<ul style="list-style-type: none"> • Make sure that the power required by the welding process is lower than the maximum rated power output. • Check that the operating conditions are in compliance with the welding power source data plate specifications. • Check for the presence of adequate air circulation around the welding power source.
	<p>Phase missing alarm Indicates the absence of a phase in the power supply line. The message appears at the same time as the mains protection activation LED switches on.</p>	<p>All functions disabled. <u>Exceptions:</u></p> <ul style="list-style-type: none"> • Cooling fan. 	<ul style="list-style-type: none"> • Check if the equipment power supply line has all the phases. <p><u>If the problem persists:</u></p> <ul style="list-style-type: none"> • qualified technical personnel are required for repair/maintenance jobs.
E50 C O O L I N G ALARM	<p>Cooler alarm Indicates insufficient pressure in the torch liquid cooling circuit.</p>	<p>All functions disabled. <u>Exceptions:</u></p> <ul style="list-style-type: none"> • Cooling fan. <p>The alarm message persists on the display until the first operation is performed on the user interface. <u>Signalling of the alarm depends on the following settings:</u></p> <ul style="list-style-type: none"> • Coo = on: the alarm is signalled if the cooling unit is connected to the power source and if it is running. • Coo = off: the alarm is never signalled, irrespective of the circumstances. • Coo = Aut: the alarm is signalled if the cooling unit is connected to the power source and if it is running. 	<ul style="list-style-type: none"> • Check that the connection to the cooler is correct. • Check that the "O/I" switch is set to "I" and that it illuminates when the pump is running. • Check that the cooler is filled with coolant. • Check that the cooling circuit is liquid tight, notably the torch hoses, the fuse and the internal connections of the cooler.
E04 ALARM VOUT	<p>Alarm, no-load voltage failure</p>	<p>All functions disabled. <u>Exceptions:</u></p> <ul style="list-style-type: none"> • Cooling fan. 	<ul style="list-style-type: none"> • Check to ensure the welding torch is not resting on the work-piece connected to ground. • Check that when the power source is switched on there is no short circuit between the sockets (voltage must be greater than/equivalent to Ur). <p><u>If the problem persists:</u></p> <ul style="list-style-type: none"> • Qualified technical personnel are required for repair/maintenance jobs.





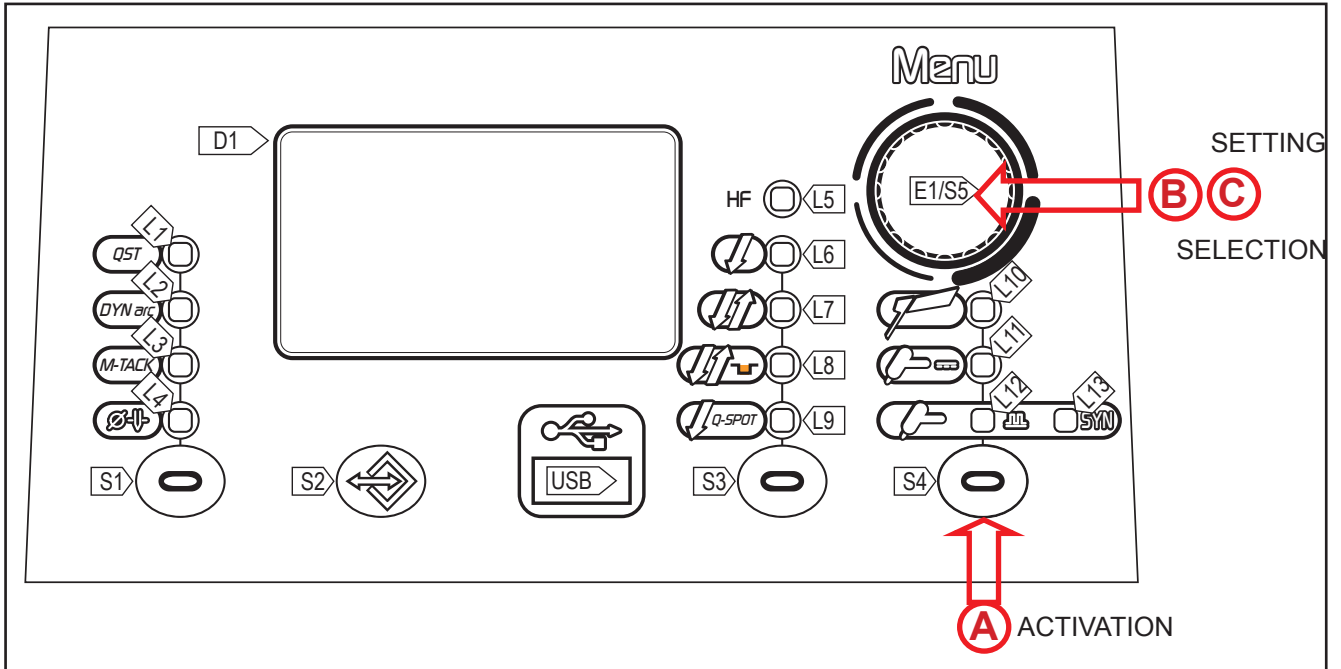

MESSAGE	MEANING	EVENT	CHECKS
E05 TORCH ALARM	<p>Torch button alarm</p> <p>Indicates that when the power source was powered up a short circuit was detected on the torch trigger input.</p> <p>When the unit has cooled, the welding power source will reset automatically.</p>	<p>All functions disabled.</p> <p><u>Exceptions:</u></p> <ul style="list-style-type: none"> • Cooling fan. 	<ul style="list-style-type: none"> • Make sure the torch trigger is not pressed, jammed, or short circuiting. • Make sure the torch and torch connector are intact.
E65 INDUCTAN- CE ALARM	<p>It indicated and excessive inductance in the welding circuit.</p> <p>To reset the welding press a user interface key.</p>	<p>All functions are disabled.</p> <p>Exceptions:</p> <p>Cooling fan.</p> <p>Cooling unit (if switched on).</p>	<ul style="list-style-type: none"> • Check that the welding cables are not excessively long and/or wound up. • Make sure that the set AC frequency is not excessively high. • If the workpiece to be welded features inductive characteristics (windings, etc.), move the earth clamp as to minimise as much as possible the distance between the clamp and the welding arc..

8 MMA WELDING

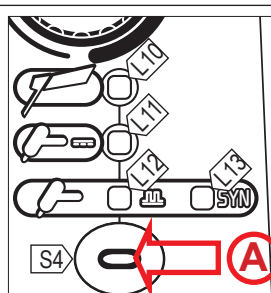
8.1 MMA WELDING - FIRST LEVEL MENU



<p>A</p> 	<ul style="list-style-type: none"> Press the S4 button  to activate the MMA mode. <p>L 10 MMA</p>
<p>B</p>	<ul style="list-style-type: none"> Press the S5 button  to scroll the list of settings to edit. <ul style="list-style-type: none"> The setting to edit and its value are shown in the display D1.
<p>C</p>	<ul style="list-style-type: none"> Using the encoder E1 , edit the value of the selected setting. The value is saved automatically.

Tab. 3 - Parameters of the 1st level menu: MMA

SETTING	MIN	DEFAULT	MAX	NOTES
WELDING CURRENT MAXIMUM CURRENT WITH REMOTE CONTROLLER	10 A	80 A	MAX A	MAX: Maximum value of welding current
HOT-START	0 %	*SYn	100 %	Only MMA
ARC FORCE	0 %	*SYn	250 %	Only MMA

- WELDING CURRENT

- This parameter regulates the primary welding current value.

- MAXIMUM CURRENT WITH REMOTE CONTROLLER

- The maximum output current value that can be achieved with foot pedal controller external reference.

- HOT-START

- This parameter aids electrode melting at the time of arc striking. It is set as a percentage referred to the value of the following parameter: **WELDING CURRENT**. The value is limited to 250A max.
- Consequences of a higher value:
 - Ease of activation; Greater starting spatter; increase in the activation area.
- Consequences of a lower value:
 - Difficulty of activation; Less starting splatter; Reduction in the activation area.

- ARC FORCE

- This parameter helps to avoid electrode sticking during welding. It is set as a percentage referred to the value of the following parameter: **WELDING CURRENT**
- Consequences of a higher value:
 - Fluency factors in welding; Arc welding stability; Increased melting of the electrode within the workpiece; More weld spatter.
- Consequences of a lower value:
 - The arc is extinguished more easily, less welding spatter.





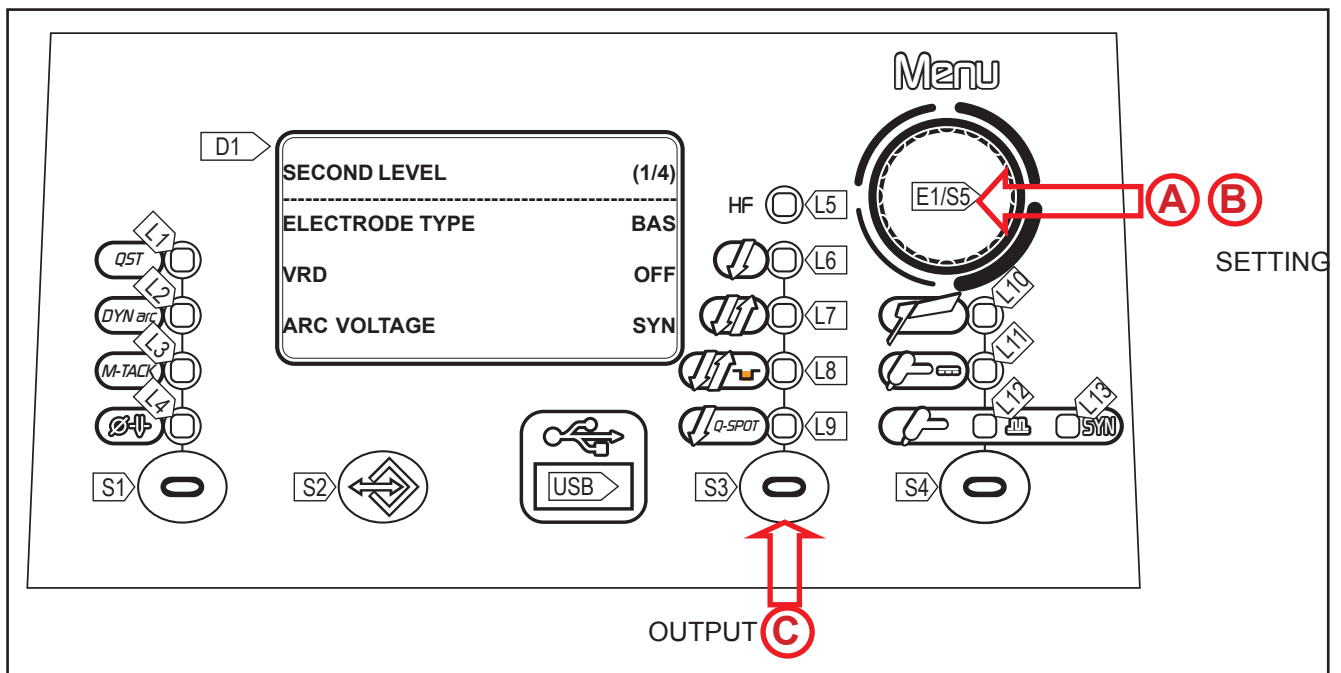

***SYN:** This code indicates that parameters control is synergic. The optimal value of this parameter is set automatically by the microprocessor on the basis of the preset welding current value.

When SYN is installed, to display the synergic value press the following button: S3.

This value can be displayed but it is not user-adjustable..

8.2 MMA WELDING -SECOND LEVEL MENU



- | | |
|----------|----------------------------------------------------------------------------------------------------------------------------------------------------------------------------------------------------------------------------------------------------------------------------------------------------------------------------------------------------------------------------------------------------------------------------------------------------------------------------------------------------------------------------------------------------------------------------------------------------------------------------------------------------------------------------------------------|
| A | <ul style="list-style-type: none"> Hold down the S5 button  button for <u>3 seconds to access the 2nd level menu</u>. <ul style="list-style-type: none"> The setting to edit and its value are shown in the display D1. |
| B | <ul style="list-style-type: none"> Select with l'encoder E1  the setting to be edited. Press the S5 button  to confirm. Using the E1 , edit the value of the selected setting. The value is saved automatically. Press the S5 button . It returns to the list of settings. |
| C | <ul style="list-style-type: none"> Exit with confirmation <ul style="list-style-type: none"> Press the S3/S4 button . |

Tab. 4 - Parameters of the 2nd level menu: MMA mode

SETTING	MIN	DEFAULT	MAX	NOTES
ELECTRODE TYPE	bAS	bAS	bAS= basic rUt= rutile Crn= chromium/nick- el ALU= aluminium	Only MMA
OUTPUT VOLTAGE REDUCTION	OFF	OFF	ON	The value is permanently set to "ON" in VRD series generators
LONG ARC VOLTAGE	37	*SYn	70	Only MMA
REMOTE CONTROL	OFF	OFF	ON	

- ELECTRODE TYPE

- This parameter allows for the selection of the type of electrode to be used. The selection automatically allows the optimum welding parameters to be set.

- OUTPUT VOLTAGE REDUCTION (VRD)

- This parameter reduces the potential across the welding sockets when welding is not in progress.
 - The arc strike procedure is as follows:
 - Touch the workpiece with the electrode tip.
 - Raise the electrode.
 - Power is released for several seconds.
 - Touch the workpiece with the electrode tip.
 - The welding arc will strike.

- LONG ARC VOLTAGE

- This parameter inhibits power output when the potential between electrode and workpiece exceeds the pre-set threshold level.
 - Consequences of a higher value:
 - The welding arc is kept triggered also with the electrode detached from the workpiece being soldered.
 - Consequences of a lower value:
 - Faster exit from weld.

***SYN:** This code indicates that parameter control is synergic. The optimal value of this parameter is set automatically by the microprocessor on the basis of the pre-set welding current value.



- When SYN is installed, to display the synergic value press the following button: **S5**.
- This value can be displayed but it is not user-adjustable.

- REMOTE CONTROL

- This parameter enables the unit to receive the current reference signal from a remote control.

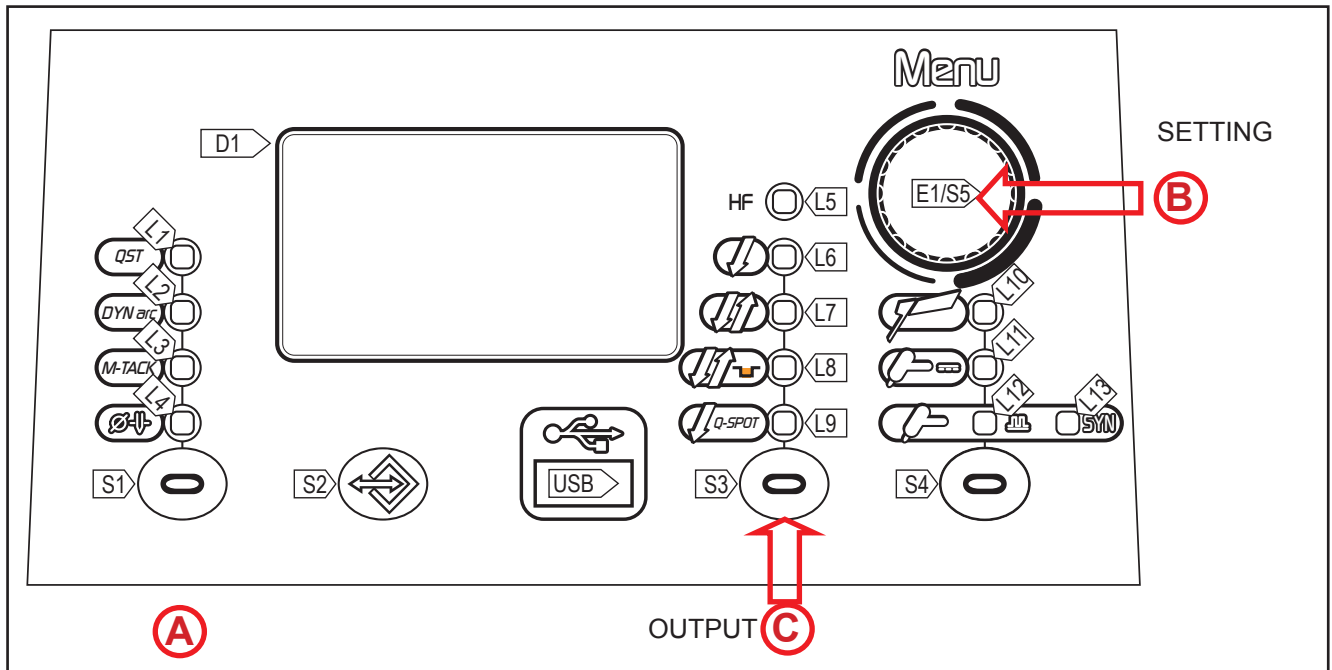
8.3 MMA WELDING - SPECIAL FUNCTIONS



- (A)** ○ Press the **S1** button  to activate the special function.
 - The setting to edit and its value are shown in the display **D1**.
- (B)** ○ Using the **encoder E1** , edit the value of the selected setting. The value is saved automatically.
- (C)** ○ **Exit with confirmation**
 - Press the **S3/S4** button .

Tab. 5 - Special functions in MMA mode

SETTING	MIN	DEFAULT	MAX	NOTES
DYNAMIC ARC	OFF	OFF	ON	Not available with MMA POLARITY = AC

- DYNAMIC ARC

- Welding power remains constant even when the distance between electrode and workpiece changes.
- Consequences of a higher value:
 - Prevents electrode bonding; Thin gauge sheets are easily distorted.

9 TIG WELDING

9.1 TIG WELDING - FIRST LEVEL MENU

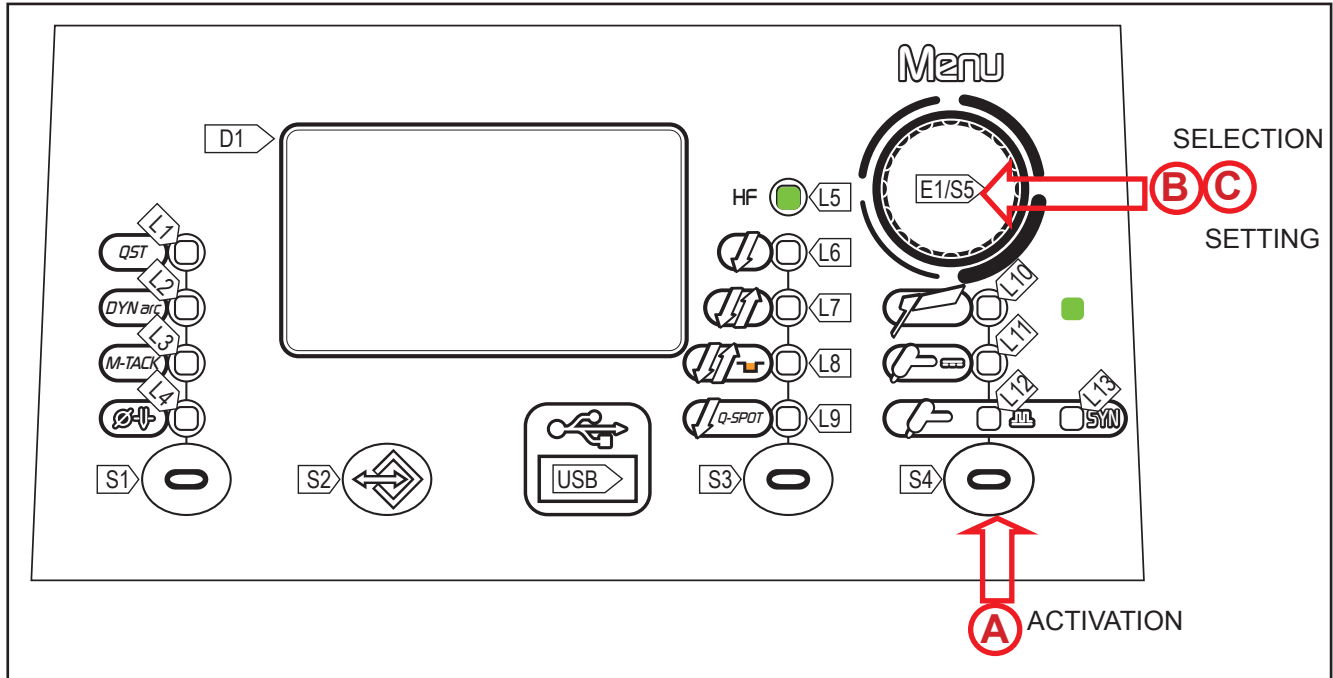

- Press the **S4** button to activate the TIG mode.

(A)

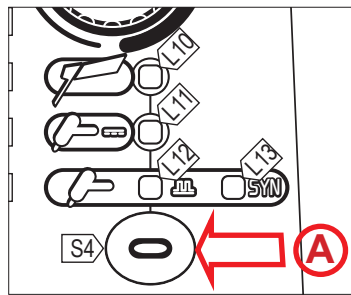

L 11 **CONTINUOUS DC TIG**
L 12 **PULSED DC TIG**
L 12 + L 13 **SYNERGIC PULSED DC TIG**

(B)

- Press the **S5** button to scroll the list of settings to edit.
- The setting to edit and its value are shown in the display **D1**.

(C)

- Using the **encoder E1** , edit the value of the selected setting. The value is saved automatically.

(i) Certain settings are available only after other torch button parameters or procedures have been enabled or set.

Tab. 6 - Parameters of the 1st level menu: TIG DC, CONTINUOUS mode

SETTING	MIN	DEFAULT	MAX	USEFUL ADVICE
PRE-GAS TIME	0.0 s	0.1 s	10.0 s	Recommended value 0-3s
STARTING CURRENT	5 A	50 A	500 A	Recommended value 30% or 15A
	2 %	50 %	200 %	
SLOPE UP	0.0 s	0.0 s	25.0 s	Recommended value 0-1s
WELDING CURRENT MAXIMUM CURRENT WITH REMOTE CONTROLLER	5 A	80 A	MAX A	MAX: Maximum value of welding current
SECOND CURRENT B-LEVEL	10 %	50 %	200 %	
DOWN SLOPE	0.0 s	0.0 s	25.0 s	Recommended value 0-5s
FINAL CURRENT	5 A	5 A	MAX A	MAX: Maximum value of welding current Recommended value 30%
	5 %	5 %	80 %	
POST GAS TIME	0.0 s	10.0 s	25.0 s	Recommended value 8-0s

Tab. 7 - Parameters of the 1st level menu: PULSED TIG DC mode, SYNERGIC PULSED TIG DC mode

SETTING	MIN	DEFAULT	MAX	USEFUL ADVICE
PRE-GAS TIME	0.0 s	0.1 s	10.0 s	Recommended value 0.3s
STARTING CURRENT	5 A	50 A	MAX A	MAX: Maximum value of welding current Recommended value 30 % or 15 A
	2 %	50 %	200 %	
SLOPE UP	0.0 s	0.0 s	25.0 s	Recommended value 0.1s
WELDING CURRENT MAXIMUM CURRENT WITH REMOTE CONTROLLER	5 A	80 A	MAX A	MAX: Maximum value of welding current
SECOND CURRENT B-LEVEL	10 %	50 %	200 %	
BASE CURRENT	1 %	40 %	200 %	Recommended value 40 %
PEAK TIME / CYCLE TIME	1 %	50 %	99 %	Recommended value 30 %
	0.1 s	5.0 s	5.0S	Available with "TYPE OF PULSED=SLOW.
PULSED CURRENT FREQUENCY	0.1 Hz	100 Hz	2.5 kHz	<ul style="list-style-type: none"> Recommended value 1-4Hz for low frequency welding. Recommended value 1kHz with 80% base current and 50% CYCLE for high frequency welding.
BASE TIME	0.1 s	5.0 s	5.0 s	Available with "TYPE OF PULSED=SLOW.
DOWN SLOPE	0.0 s	0.0 s	25.0 s	Recommended value 0.5
FINAL CURRENT	5 A	5 A	MAX A	MAX: Maximum value of welding current Recommended value 30 %
	5 %	5 %	80 %	
POST GAS TIME	0.0 s	10.0 s	25.0 s	Recommended value 8.0s

For a better understanding of the parameter functions described in the table, refer to the following diagram.

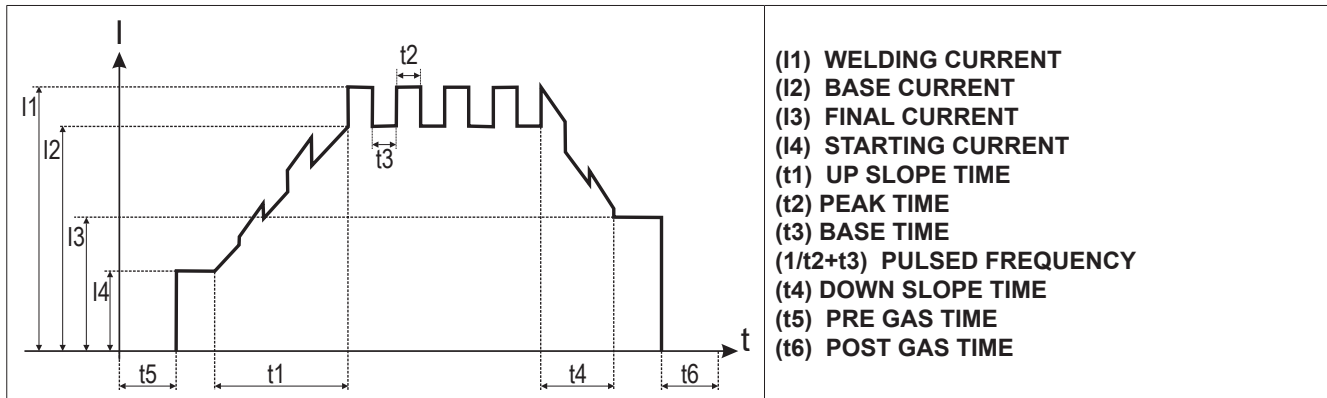

- **The SYNERGIC PULSED TIG DC** enables a highly concentrated arc to be obtained. It is a very stable arc and moves the pool with strong fluctuations. It is ideal for use in spot welding and the creation of thin fillets. It is recommended for thin gauge sheets and in particular where a very stable arc is required (viscous pools)

In this mode, the welding parameters are pulsed: BASE CURRENT; PEAK TIME; PULSED FREQUENCY are only displayed and cannot be modified.

- PRE-GAS TIME

- o Time of gas delivery before the arc strike.
- o This adjustment is required when fixing points must be created or when welding in hard-to-reach positions that call for the presence of inert atmospheres before striking the arc.
- Consequences of a higher value:
 - This parameter allows a shielded environment to be created, thereby eliminating contaminants at the start of the welding pass.

- STARTING CURRENT

- o Unit current output value immediately after the arc strike. The value of this parameter can be set as a percentage of the welding current or as an absolute value expressed in Amperes. The parameter is displayed but it is not used during the welding process when the following setting is present: MULTI TACK = ON The usefulness of having an adjustable initial welding current is that of avoiding welding the part with excessively high current values and thus potentially damaging it. Particularly useful when welding thin sheets.

- SLOPE UP

- o Time during which the current changes from the starting value to the welding value by means of a slope.
- o This setting is used to avoid damaging the edges of the joint with excessively high current values at the moment of arc striking. The value of the main welding current is increased gradually in order to control the uniformity of material deposition and weld penetration. The parameter is not used during the welding process when the following setting is present: MULTI TACK = ON

- WELDING CURRENT

- o This parameter regulates the primary welding current value.

- SECOND CURRENT B-LEVEL

- With a rapid press and release (less than 0.5 seconds) of the torch trigger during welding, the output current value switches to the value set by means of the “B-level second current” parameter.
- This function makes it possible to avoid interrupting the welding process when the geometry of the workpiece changes; alternatively, the welding current can be reduced to decrease heating of the part if it becomes too hot during execution of the welding process.
- In DC TIG welding, the parameter is useful when welding different gauge workpieces during the same pass; when moving between different gauges the output current can be changed simply by pressing the torch trigger.

- BASE CURRENT

- Pulsed wave minimum current.
- Consequences of a higher value:
 - - Faster creation of weld pool.
 - - Increase of heat-affected zone.

- PEAK TIME

- Time for which the current pulse is at the maximum value.
- The SET UP, PULSED TYPE=FAST settings, the adjustment is a % of the PULSED CYCLE (CYCLE TIME=1/PULSED FREQUENCY).
- In the settings for SET UP, PULSED TYPE = SLOW, the adjustment is expressed in seconds.
- Consequences of a higher value:
 - - Greater width of the beading and greater welding penetration.
 - - Facility to make deeper cuts.
- Consequences of a lower value:
 - - Reduction of the bead and of heat-affected zone.
 - - Difficult to create a weld pool.

- PULSED CURRENT FREQUENCY

- The greater the frequency, the tighter the bead welding and greater the welding time. Increasing the frequency, restricts the heat affected zone. A high frequency (kHz) pulsed arc is suitable for flat beading (head to head or over head)
- Consequences of a higher value:
 - - Slower melt speed.
 - - Reduction of heat-affected zone.

- BASE TIME

- Time during which current output is at the base value. Available with settings for SET UP, PULSED TYPE = SLOW, the adjustment is expressed in seconds.
- Consequences of a higher value:
 - - The filler material is spread more evenly.
 - - Increase of heat-affected zone.

- DOWN SLOPE

- Time during which the current changes from the welding value to the end value by means of a slope. Prevents the formation of craters in the process of turning off the arc. The parameter is not used during the welding process when the following setting is present: MULTI TACK = ON

- FINAL CURRENT





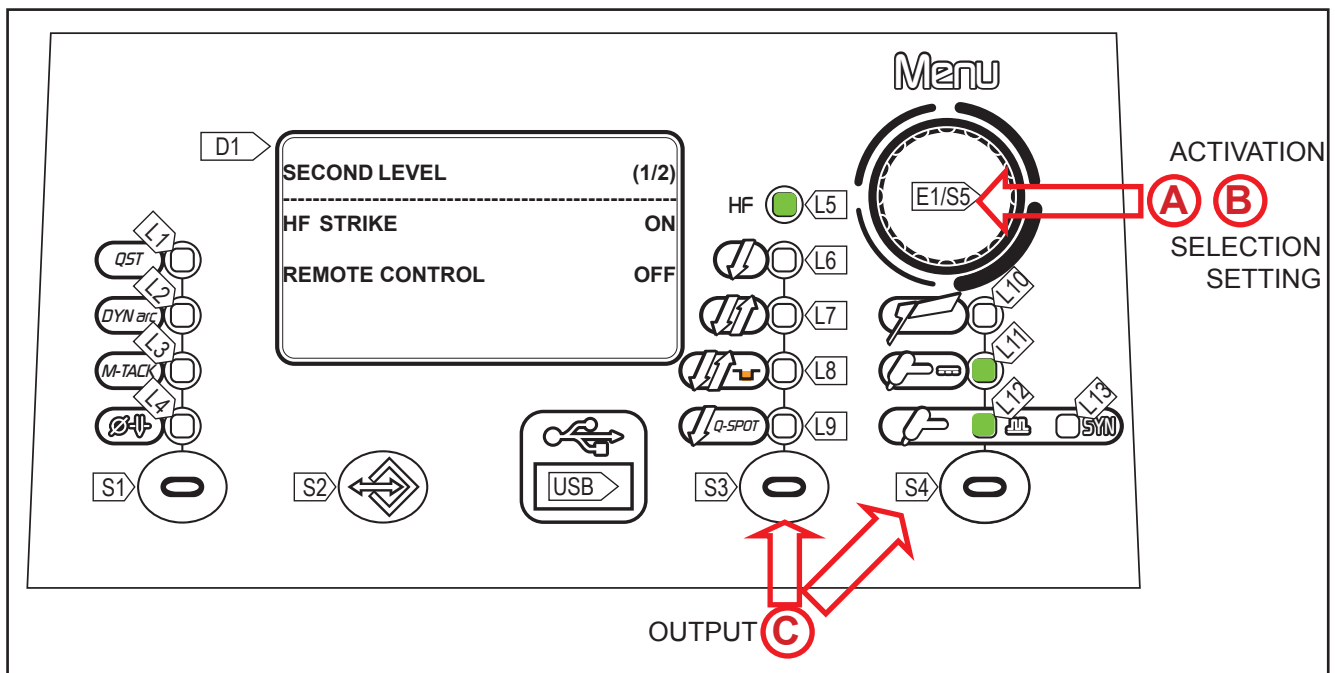

- During electrode welding the parameter makes it possible to obtain a uniform deposit of filler material from the start to the end of the welding process, closing the deposition crater with a current such as to deposit a final droplet of filler material.
- The value of this parameter can be set as a percentage of the welding current or as an absolute value expressed in Amperes.
- The parameter is displayed but it is not used during the welding process when the following setting is present: MULTI TACK = ON
- By keeping the torch trigger pressed during the 3rd time, the crater filler current is maintained thereby ensuring optimal crater filling, until the post gas time is started by releasing the torch trigger (4th time).

- POST GAS TIME

- Time of post gas delivery when the welding arc is extinguished.
- Consequences of a higher value:
 - More effective pickling (improved appearance of workpiece at the end of the welding pass).
 - - Higher gas consumption.
- Consequences of a lower value:
 - - Lower gas consumption.
 - - Oxidation of electrode tip (more difficult arc strike).

9.2 TIG WELDING - SECOND LEVEL MENU



- | | |
|------------|--------------------------------------------------------------------------------------------------------------------------------------------------------------------------------------------------------------------------------------------------------------------------------------------------------------------------------------------------------------------------------------------------------------------------------------------------------------------------------------------------------------------------------------------------------------------------------------------------------------------------------------------------------------------------------------------|
| (A) | <ul style="list-style-type: none"> Hold down the S5 button  for <u>3 seconds to access the 2nd level menu.</u> <ul style="list-style-type: none"> The setting to edit and its value are shown in the display D1. |
| (B) | <ul style="list-style-type: none"> Select with encoder E1  the setting to be edited. Press the S5 button  to confirm. Using the E1 , edit the value of the selected setting. The value is saved automatically. Press the S5 button . It returns to the list of settings. |
| (C) | <ul style="list-style-type: none"> Exit with confirmation <ul style="list-style-type: none"> Press the S3/S4 button . |

(i) Certain settings are available only after other torch button parameters or procedures have been enabled or set.

Tab. 8 - Parameters of the 2nd level menu: DC TIG mode

SETTING	MIN	DEFAULT	MAX	NOTES
SPOT TIME	0.01s	0.01s	10.0s	Solo con 2 Tempi SPOT
PAUSE TIME	0.01s	OFF	10.0s	Only with 2 STROKE SPOT Only with HF=ON
HF STRIKE	OFF	ON	ON	
REMOTE CONTROL	OFF	OFF	ON	
MINIMUM PEDAL CURRENT	1 %	5 %	90 %	Only with the PEDAL

- SPOT TIG TIME

- Only available with 2 STROKE SPOT When the torch trigger is pressed the welding arc persists for the time set in the parameter. Press the torch trigger again to resume the welding process.
- The result of this is a very precise, non-oxidized welding spot without any plastic deformation of the sheet.

- PAUSE TIME

- Available only with 2 Stroke SPOT and arc strike with HF activated. It causes a pre-set pause time between two spot-welding times. Press the torch trigger to obtain the welding arc for the time set with the parameter SPOT-WELDING TIME. The arc then remains extinguished for the time set by PAUSE TIME and then starts again. This process continues until the torch trigger is released. When the parameter is set to OFF, the operating mode of the Q-SPOT is standard.

- HF ARC START

- This parameter enables the arc strike in the TIG welding procedure by means of a high frequency (HF) current discharge. The high frequency arc strike (HF) prevents the inclusion of impurities at the start of the weld pass. If set to OFF, the ignition will be of a 'LIFT ARC' strip type
 - **HF:** This type of ignition occurs by means of a high-voltage electric discharge but of low amperage (HF) between the electrode tip and the weld workpiece. Once the electric arc is established the generator stops delivering the HF charge. This type of ignition in addition to being very easy and immediate, allows the electrode life to be extended and to keep it very pure allowing the operator to work with a very precise and stable arc.

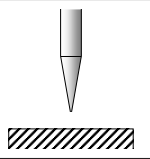
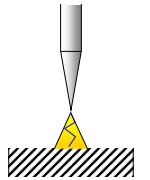
HF ARC IGNITION PROCEDURE		
1		Position the tungsten electrode on the ignition point, so that there is a distance of about 2-3mm between the electrode and the workpiece
2		Press the torch button according to the mode selected. The voltaic arc ignites without touching the weld workpiece.

- **LIFT-ARC:** This type of arc blow is derived from a short low-amperage circuit (to avoid electrode damage) that the operator created between the electrode tip and the workpiece and the consequent rise of the electrode tip that maintains the current flow by creating the so-called electric arc. It is advisable to use LIFT-ARC priming in applications such as maintenance of machinery in operation, welding close to printed circuits or soldering near computers.

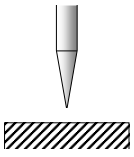
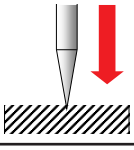
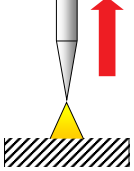
PROCESS FOR ARC IGNITION IN LIFT-ARC MODE:		
1		Position the tungsten electrode on the ignition point, so that there is a distance of about 2-3mm between the electrode and the workpiece.
2		Touch the piece with the electrode and press the torch button according to the mode selected.
3		Lift the torch to strike the arc.

- MINIMUM PEDAL CURRENT

- Minimum output current value with foot pedal controller external reference. The current is set as a percentage with respect to the “maximum foot pedal current” parameter.

9.3 TIG DC WELDING - SPECIAL FUNCTIONS MENU

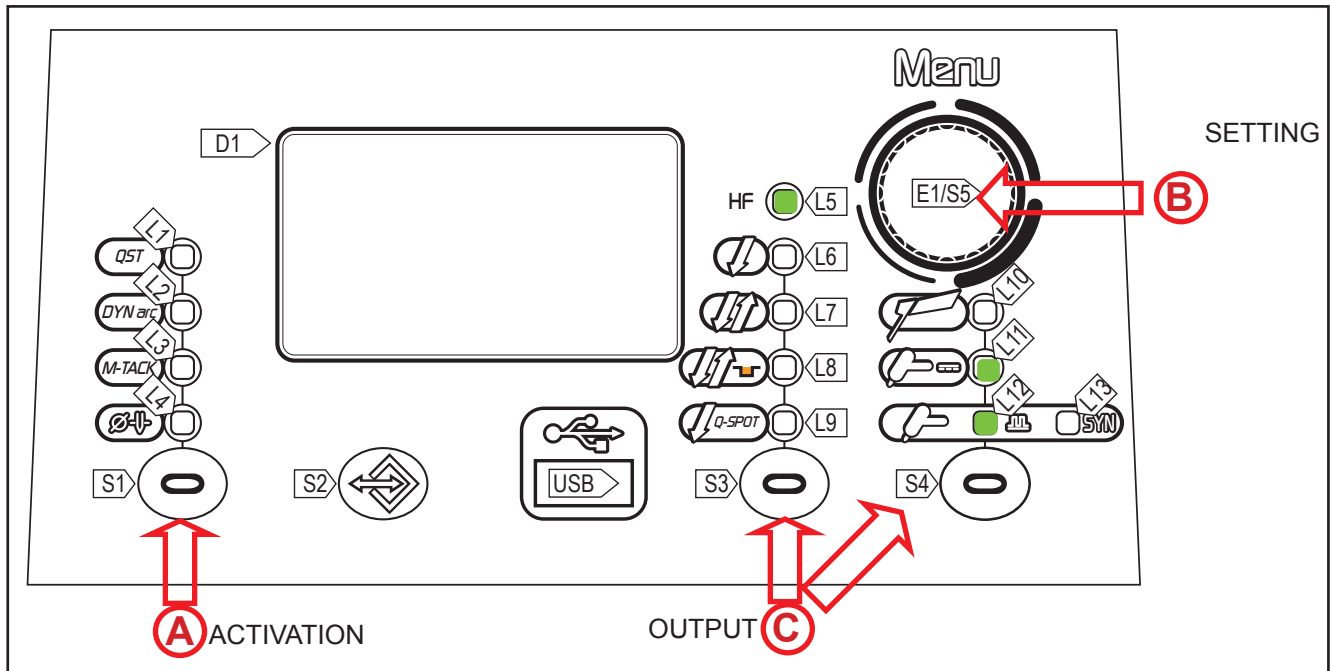













- A**
 - Press the **S1 button** to activate the special function.
 - The setting to edit and its value are shown in the display **D1**.
 - Press the **S1 button** to scroll the list of settings to edit.
- B**
 - Using the **encoder E1** , edit the value of the selected setting. The value is saved automatically.
- C**
 - **Exit with confirmation**
 - Press the **S3/S4 button** .

i Certain settings are available only after other torch button parameters or procedures have been enabled or set.

Tab. 11 - Special functions in TIG DC mode

SETTING	MIN	DEFAULT	MAX	NOTES
Q-START	0.1 s	oFF	10.0 s	See Table 12
DYNAMIC ARC	1	oFF	50	See Table 13 (not with SYNERGIC PULSED TIG)
MULTI TACK	0.5Hz	oFF	6.0Hz	See Table 14 (not with SYNERGIC PULSED TIG)

Tab. 12 - Special functions in DC TIG mode - summary of the combinations

MODE → PROCEDURE ↓	 = + HF  = + HF	 = + HF  = + HF with MULTI-TACK > 0 s	SYN + HF	 =  =	SYN
 with remote control	<i>QST</i> <i>DYN arc</i> <i>M-TACK</i> ∅	<i>M-TACK</i> ∅	<i>M-TACK</i> ∅	<i>M-TACK</i> ∅	∅
 with remote control	<i>QST</i> <i>DYN arc</i> <i>M-TACK</i> ∅	<i>M-TACK</i> ∅	<i>M-TACK</i> ∅	<i>DYN arc</i> ∅	∅
 with remote control	<i>QST</i> ∅	<i>QST</i> ∅	∅	∅	∅
 with remote control	∅	∅	∅	∅	∅
 with foot pedal remote control	<i>QST</i> <i>M-TACK</i> ∅	<i>M-TACK</i> ∅	<i>M-TACK</i> ∅	∅	∅
 with foot pedal remote control	∅	∅	∅	∅	∅

- Q-START

- This parameter allows the unit to start in synergic pulsed TIG mode for the pre-set time interval, before switching automatically to the welding procedure selected on the interface panel. The parameter creates the weld pool more quickly than a standard starting time of the material because it creates a movement of the two flaps up to speed up the join.
- This parameter is useful when spot welding thin gauge sheet.

Tab. 13 - Recommended Q-START parameters

CORNER/BUTT JOINT		
Sheet thickness (mm)	Current (A)	Q start value (seconds)
1.0mm	35A - 50A	0.5 - 1.0
2.0mm	50A - 80A	
3.0mm	80A - 140A	
4.0mm	140A - 170A	

- DYNAMIC ARC

- This function allows, on the reduction of the arc voltage, an increase of the welding current and vice versa. The size of the DynamicArc variation may be individually adjusted to a value between 1A to 50A. For example, an increase of 50A for 1 volt variation.
- This value must be set depending on the material thickness, and the type of processing to be carried out (values between 1A and 20A for thin layers while a value between 20A and 50A for medium-thick layers).
- Welding power remains constant even when the distance between electrode and workpiece changes.
- Consequences of a higher value:
 - The welding arc concentration remains unchanged.
 - Prevents electrode sticking.
 - Increased welding speed.
 - Minor plastic deformity in the welded workpiece.
 - Greater penetration at the apex.
 - Concentrated heat contribution only to the welding and not to the surrounding area.
 - Minor oxidation of the piece and therefore lower post-weld re-work costs.
 - Better control of first application in gaps (useful for pipe fitters and installers).
 - Ease of welding even for pieces which are not properly prepared.
 - Minimization of errors and greater arc stability with motion variations.

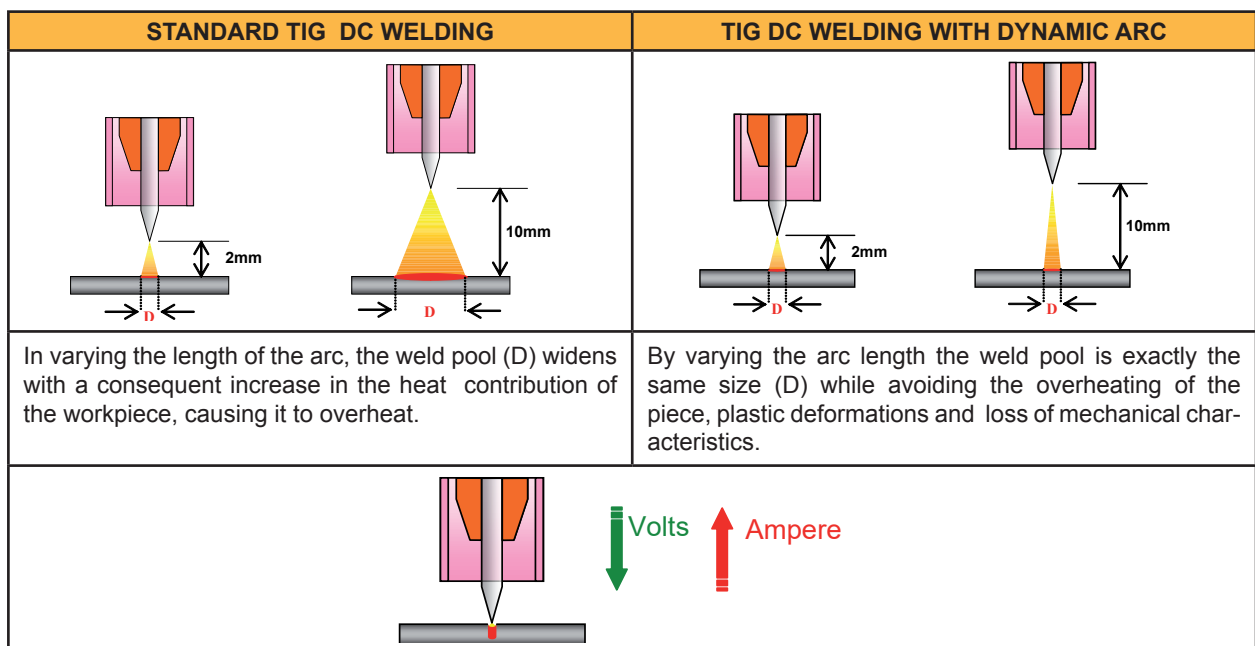

Tab. 14 - Recommended DYNAMIC ARC parameters

ANY TYPE OF JOINT		
Sheet thickness (mm)	Current (A)	DnyArc Value (Amperes)
1.0 mm	35A - 50A	5 - 10
2.0 mm	50A - 80A	10 - 15
3.0 mm	80A - 140A	15 - 25
4.0 mm	140A - 170A	25 - 50

In order to have optimum control of the arc, it is advisable to ignite it at a distance of between 4-5mm from the initial point of the joint (point zero) .

- MULTI TACK

- This consists of continual welding that allows optimum control of the thinnest gauge sheets/bevels with irregular shapes.
- Benefits:
 - Major reduction in oxidisation with the absence of deformations.
 - This parameter allows thin gauge sheet to be welded without deformation.
- Consequences of a higher value:
 - Welding of thinner gauge sheet without deformation.
 - Less melting of material, slower welding process.

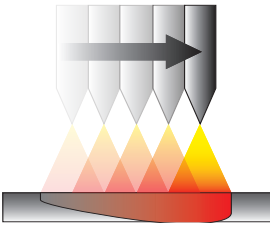
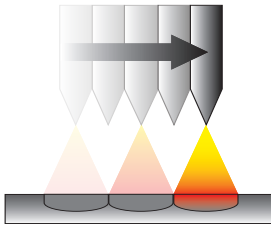
TIG DC WELDING CONTINUOUS	TIG DC WELDING WITH MULTITACK
	
<p>Continuous TIG welding provides continuous energy which prevents the cooling of the piece and does not cause overheating with excessive penetration and excessive distortion effects. Using the pulsed TIG reduces the effect of overheating but it does not solve it completely as the arc will remain on and will still provide energy and heat.</p>	<p>The series of triggers repeated over time allow the piece to disperse the heat between a trigger and another. By adjusting the MultiTack frequency the weld penetration, speed of execution and in particular the control of the heat input can be optimised as well as any consequent deformation of the piece.</p>
<p>When welding corner joints, the Multitack may be used with excellent results. The welding remains white and free of any oxidation often avoiding the post welding cleanup treatment with acids.</p>	

Tab. 15 - Recommended MULTITACK parameters

CORNER/BUTT JOINT		
Sheet thickness (mm)	Current (A)	Multitack FREQUENCY (Hz)
0.6 mm	40A - 60A	1.0 - 1.5
0.8 mm	60A - 80A	1.0 - 1.5
1.0 mm	80A - 100A	1.0 - 1.5
1.5 mm	90A - 110A	1.0 - 1.5
2.0 mm	110A - 130A	1.0 - 1.5
	130A - 150A	1.5 - 2.0
2.5 mm	150A - 160A	1.0 - 1.5
	160A - 170A	1.5 - 2.0
3.0 mm	170A - 180A	1.0 - 1.5
	180A - 200A	1.5 - 2.0

- It is recommended that a preflow time of between 0.3 - 0.5 seconds be used in order to have optimum protection right from the start, thus avoiding the oxidation of the initial part of the weld. This is also the same for the final part where it is recommended that a post gas time of not less than 3 seconds is used.

- ELECTRODE DIAMETER

- The parameter optimizes the DC TIG welding arc strike on the basis of the diameter of the chosen electrode.

10 TORCH TRIGGER PROCEDURE

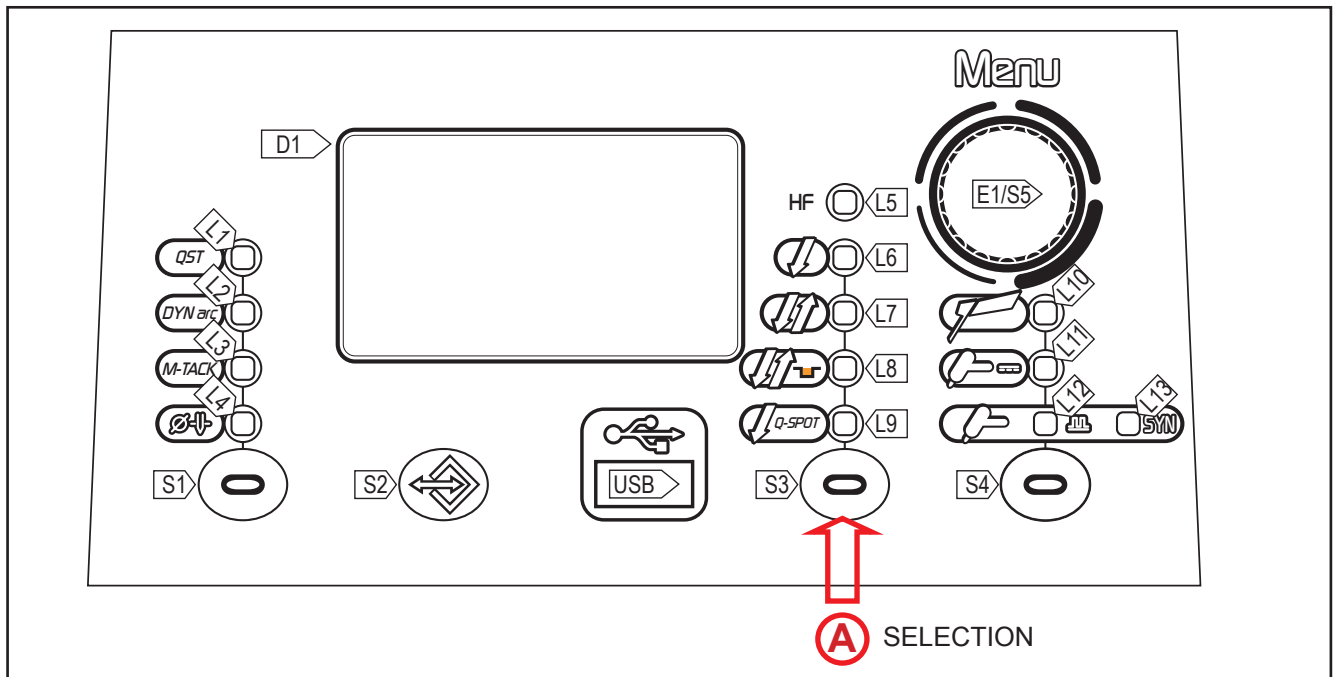

- Press the **S3** button to select the desired PULSED TORCH mode.

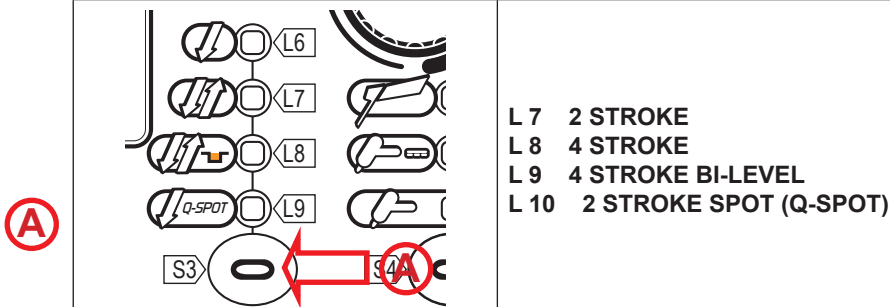











- L 7 2 STROKE
- L 8 4 STROKE
- L 9 4 STROKE BI-LEVEL
- L 10 2 STROKE SPOT (Q-SPOT)

Depending on the welding mode selected, specific torch button procedures are available. The availability of certain procedures depends on whether or not certain parameters or functions of the unit are enabled or set in the associated menus. The table shows the settings to be made to enable each procedure.

LEGEND

- 2T: _____ 2 STROKE LIFT-ARC
- 2T HF: _____ 2 STROKE WITH HIGH FREQUENCY ARC STRIKE (HF)
- 4T: _____ 4 STROKE LIFT-ARC
- 4T HF: _____ 4 STROKE WITH HIGH FREQUENCY ARC STRIKE (HF)
- 4T B-L: _____ 4 STROKE B-LEVEL
- 4T B-L HF: _____ 4 STROKE B-LEVEL WITH HIGH FREQUENCY ARC STRIKE (HF)
- 2T Q-SPOT: _____ 2 STROKE TACKING
- 2T Q-SPOT HF: _____ 2 STROKE TACKING WITH HIGH FREQUENCY ARC STRIKE (HF)
- √: _____ Always available.
- 1: _____ Available with the following setting: HF= on

Tab. 16 - Pulsed Torch button mode table.

→ ↓	PROCEDURE							
								
MODE	2T	2T HF	4T	4T HF	4T B-L	4T B-L HF	2T Q-SPOT	2T Q-SPOT HF
 MMA								
 CONTINUOUS DC TIG	√	1	√	1	√	1	√	1
 PULSED MODE DC TIG	√	1	√	1	√	1	√	1
SYN SYNERGIC PULSED DC TIG	√	1	√	1	√	1	√	1

- 2 STROKE LIFT:

- Touch the workpiece with the torch electrode.
- Press (1T) and keep the torch trigger pressed.
- Slowly lift the torch to strike the arc.
- The welding current reaches the pre-set value, by way of an up slope time, if programmed.
- Release (2T) the trigger to start the weld completion procedure.
- The current reaches the end current value in the time set in the down slope time parameter.
- The arc is extinguished.
- Gas delivery continues for the time set in the post gas parameter.

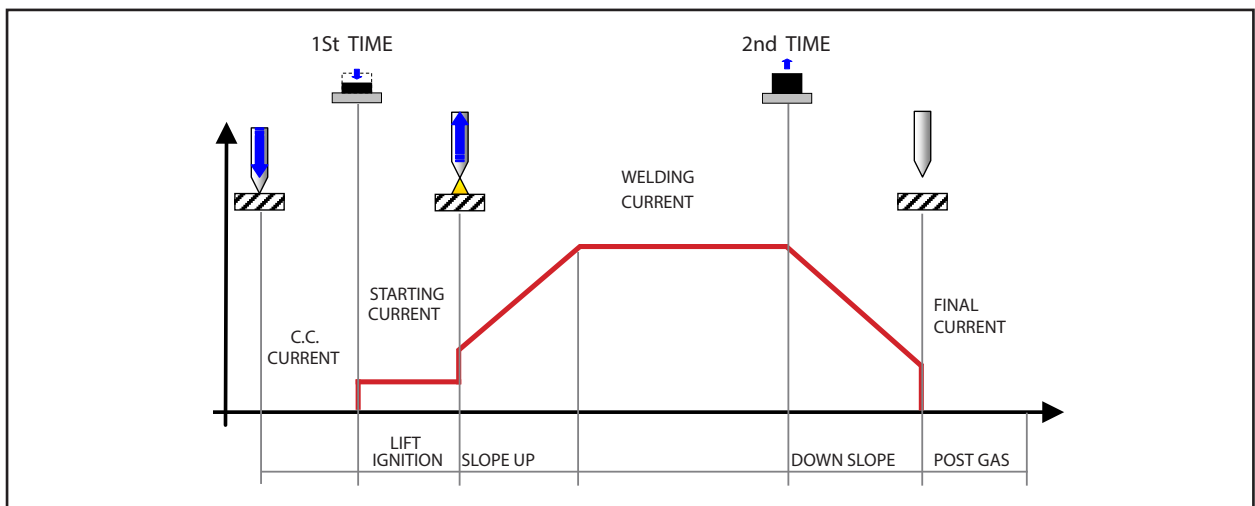

- 2 STROKE + HF

- Bring the torch up to the work until the electrode tip is approximately 2 or 3 mm away.
- Press (1T) and keep the torch trigger pressed.
- The arc strikes without contact with the workpiece and the voltage discharges (HF) cease automatically.
- The welding current reaches the pre-set value, by way of an up slope time, if programmed.
- Release (2T) the trigger to start the weld completion procedure.
- The current reaches the end current value in the time set in the down slope time parameter.
- The arc is extinguished.
- Gas delivery continues for the time set in the post gas parameter.

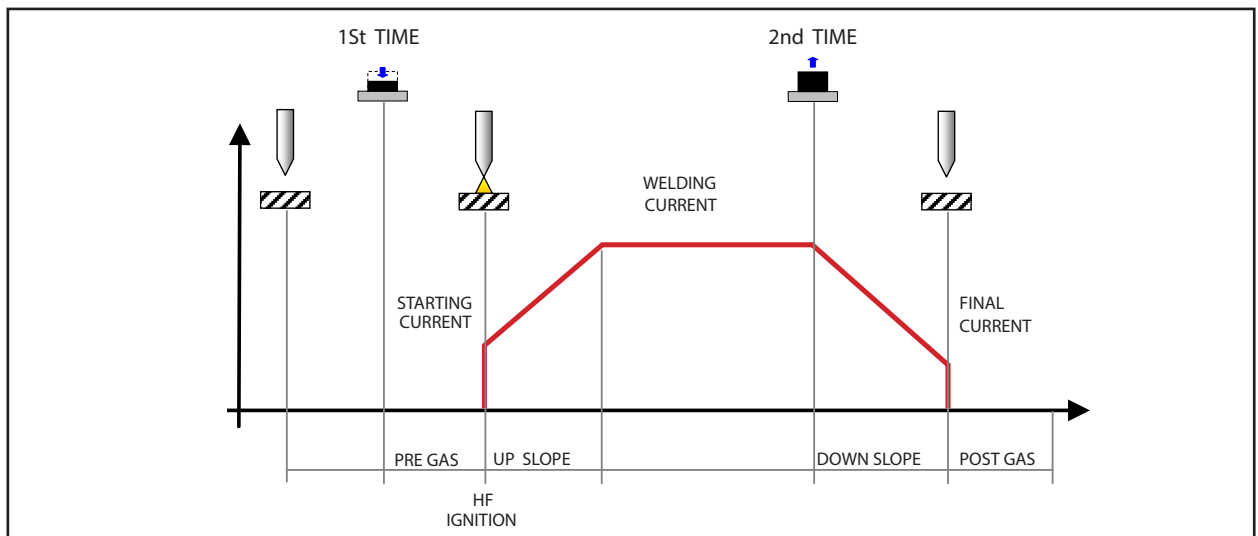

- 4 STROKE LIFT:

- Touch the workpiece with the torch electrode.
- Press (1T) and keep the torch trigger pressed.
- Slowly lift the torch to strike the arc.
- The arc strikes, the welding current assumes the pilot current value. (if activated from the SET UP menu.)
- Release (2T) the torch trigger.
- The welding current reaches the pre-set value, by way of an up slope time, if programmed.
- Press (3T) the trigger and keep it pressed to start the weld completion procedure.
- The current reaches the end current value in the time set in the down slope time parameter.
- The arc continues and the current output will be the value set in the end current parameter.
- In these conditions the weld pool can be closed (crater filler current).
- Release (4T) the trigger to extinguish the arc.
- Gas delivery continues for the time set in the post gas parameter.

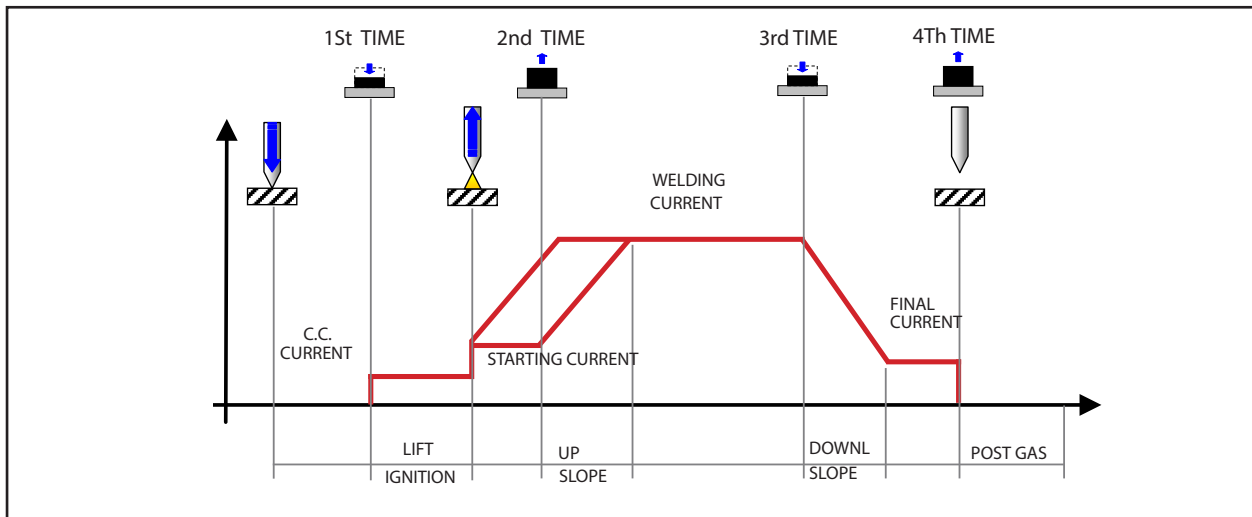

- 4 STROKE + HF

- Bring the torch up to the work until the electrode tip is approximately 2 or 3 mm away.
- Press (1T) and keep the torch trigger pressed.
- The arc strikes without contact with the part and the voltage discharges (HF) cease automatically, the welding current will assume the pilot current value. (if activated from the SET UP menu.)
- Release (2T) the torch trigger.
- The welding current reaches the pre-set value, by way of an up slope time, if programmed.
- Press (3T) the trigger and keep it pressed to start the weld completion procedure.
- The current reaches the end current value in the time set in the down slope time parameter.
- The arc continues and the current output will be the value set in the end current parameter.
- In these conditions the weld pool can be closed (crater filler current).
- Release (4T) the trigger to extinguish the arc.
- Gas delivery continues for the time set in the post gas parameter.

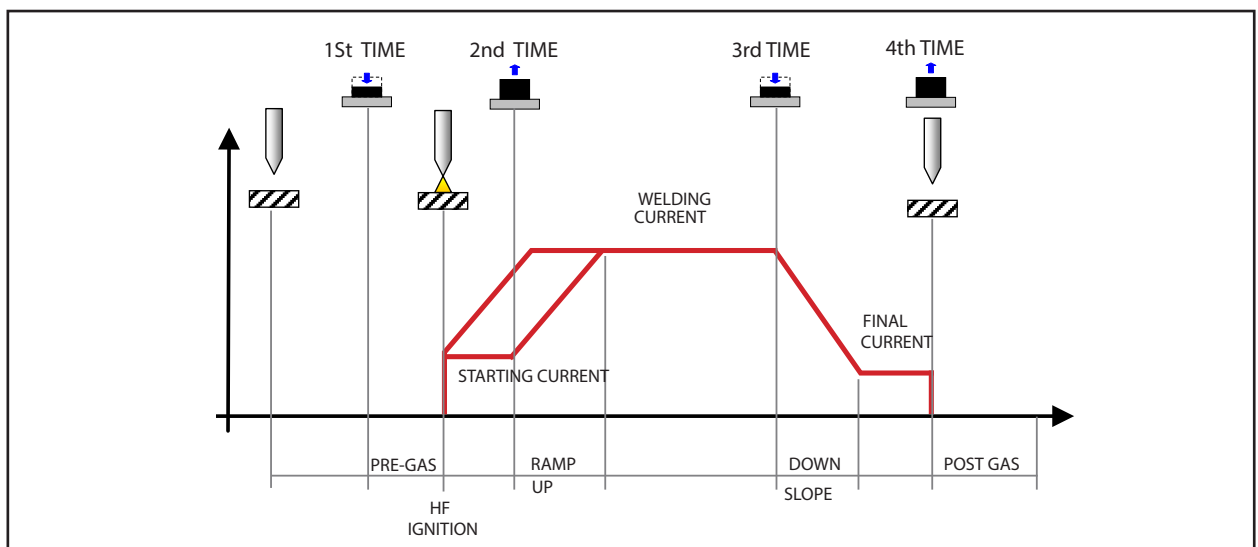

4 STROKE B-LEVEL LIFT:

- Touch the workpiece with the torch electrode.
- Press (1T) and keep the torch trigger pressed.
- Slowly lift the torch to strike the arc.
- The arc strikes, the welding current assumes the pilot current value. (if activated from the SET UP menu.)
- Release (2T) the torch trigger.
- The welding current reaches the pre-set value, by way of an up slope time, if programmed.
- Press and immediately release the torch trigger to switch to the second welding current.
- The trigger must not be pressed for more than 0.3 seconds; otherwise, the weld completion stage will start.
- When the trigger is pressed and released immediately, the system returns to the welding current.
- Press (3T) the trigger and keep it pressed to start the weld completion procedure.
- The current reaches the end current value in the time set in the down slope time parameter.
- The arc continues and the current output will be the value set in the end current parameter.
- In these conditions the weld pool can be closed (crater filler current).
- Release (4T) the trigger to extinguish the arc.
- Gas delivery continues for the time set in the post gas parameter.

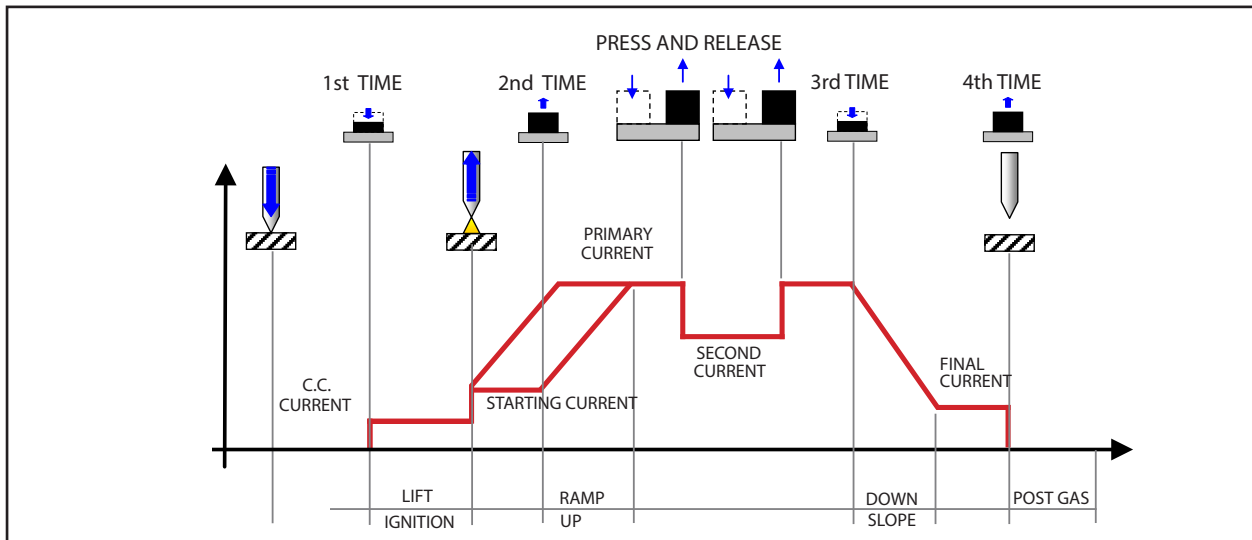

- 4 STROKE B-LEVEL:

- Bring the torch up to the work until the electrode tip is approximately 2 or 3 mm away.
- Press (1T) and keep the torch trigger pressed.
- The arc strikes without contact with the part and the voltage discharges (HF) cease automatically, the welding current will assume the pilot current value. (if activated from the SET UP menu.)
- Release (2T) the torch trigger.
- The arc strikes without contact with the workpiece and the voltage discharges (HF) cease automatically.
- The welding current reaches the pre-set value, by way of an up slope time, if programmed.
- Press and immediately release the torch trigger to switch to the second welding current.
- The trigger must not be pressed for more than 0.3 seconds; otherwise, the weld completion stage will start.
- When the trigger is pressed and released immediately, the system returns to the welding current.
- Press (3T) the trigger and keep it pressed to start the weld completion procedure.
- The current reaches the end current value in the time set in the down slope time parameter.
- The arc continues and the current output will be the value set in the end current parameter.
- In these conditions the weld pool can be closed (crater filler current).
- Release (4T) the trigger to extinguish the arc.
- Gas delivery continues for the time set in the post gas parameter.

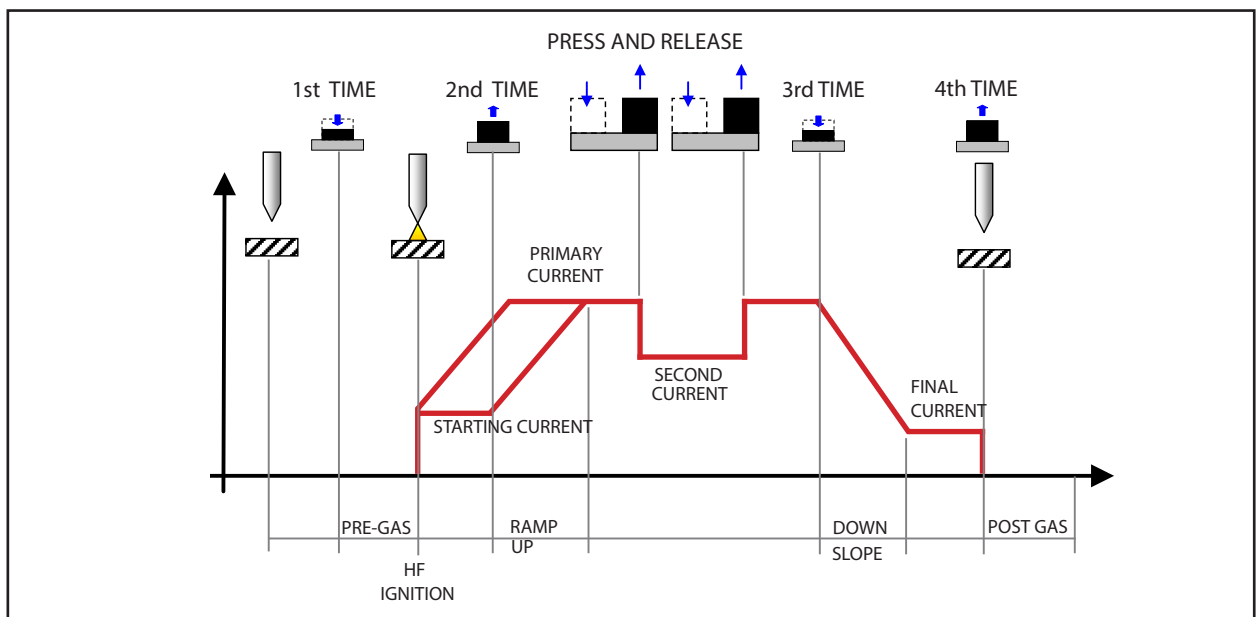

10.1 2 STROKE SPOT - Q-SPOT FUNCTION

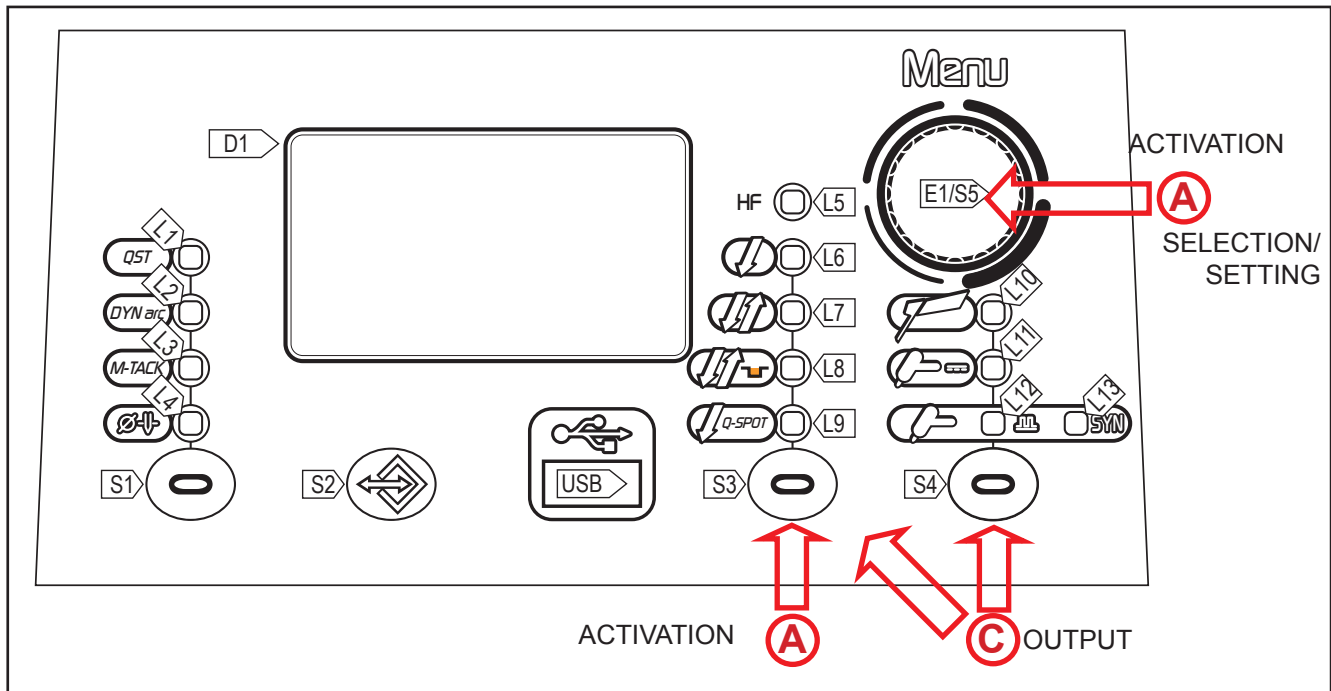

- (A)**
 - o Press the **S3** button to select the TORCH 2 STROKE SPOT BUTTON mode.
 - o Press the **S5** button for 3 seconds to access the 2nd level menu.
 - The setting to edit and its value are shown in the display **D1**.
- (B)**
 - o Select with **encoder E1** the setting to be edited.
 - o Press the **S5** button to confirm.
 - o Using the **E1** , edit the value of the selected setting. The value is saved automatically.
 - o Press the **S5** button . It returns to the list of settings.
- (C)**
 - o **Exit with confirmation**
 - Press the **S3/S4** button .

Tab. 18 - Parameters of the 2nd level menu: 2 STROKE SPOT mode

SETTING	MIN	DEFAULT	MAX	NOTES
SPOT TIME	0.01s	0.01s	10.0s	Solo con 2 Tempi SPOT
PAUSE TIME	0.01s	oFF	10.0s	Only with 2 STROKE SPOT Only with HF=ON
HF STRIKE	OFF	ON	ON	
REMOTE CONTROL	OFF	OFF	ON	
MINIMUM PEDAL CURRENT	1 %	5 %	90 %	Only with PEDAL connected

- Q-SPOT:

- This function, only present in 2 STROKE SPOT, facilitates spot-welding:
 - It allows the exact positioning of the electrode at the point to be joined. The electrode is conveniently placed at the desired location.
 - Only after lifting of the electrode, the machine emits pulse welding for the stipulated time.
 - It considerably reduces the risk of contamination of the joint with the electrode.
 - While pressing the torch button, the process may be repeated as many times as required.
- This function is ideally suited to the welding of thinner gauges, head to head position and the pipes. Place the torch with the electrode on the precise point to be fixed.
 - Press the torch trigger and then lift.
 - After lifting the torch, a precise trigger will follow.
- **Recommended:** Set the highest current possible with the lowest possible time. Value: 0.01-0.5 Sec. If the spot-welding time is less than 1.0s, the up and down slopes are eliminated automatically by the welding process, although they are displayed and can be set by the user interface.
- **Warning:** It is important to check the up and down slopes are null (0sec.)
- The Q-Spot function has a dual mode, i.e. it is possible to carry out spot welding without contact with the piece.
 - It is recommended that the spot-welding position is researched (an electrode that contacts the workpiece) for thin layers (less than 1.5mm) while for greater thicknesses, without making contact with the workpiece.

- 2 STROKE SPOT LIFT:

- Touch the workpiece with the torch electrode.
- Press (1T) and keep the torch trigger pressed.
- Slowly lift the torch to strike the arc.
- Release (2T) the torch trigger.
- The welding current reaches the pre-set value, by way of an up slope time, if programmed.
- The welding procedure continues, at the pre-set current, for the time set with the spot time parameter.
- The current reaches the end current value in the time set in the down slope time parameter.
- The arc is extinguished.
- Gas delivery continues for the time set in the post gas parameter.

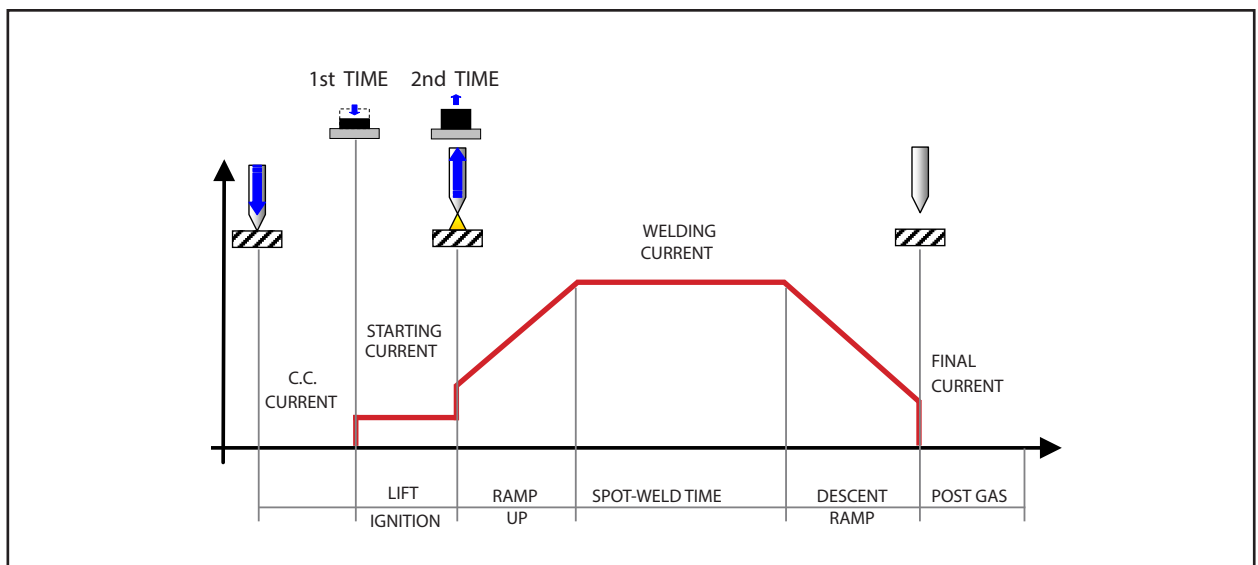

- 2 STROKE SPOT HF:

- Bring the torch up to the work until the electrode tip is approximately 2 or 3 mm away.
- Press (1T) the torch trigger.
- The arc strikes without contact with the workpiece and the voltage discharges (HF) cease automatically.
- Release (2T) the torch trigger.
- The welding current reaches the pre-set value, by way of an up slope time, if programmed.
- The welding procedure continues, at the pre-set current, for the time set with the spot time parameter.
- The current reaches the end current value in the time set in the down slope time parameter.
- The arc is extinguished.
- Gas delivery continues for the time set in the post gas parameter.

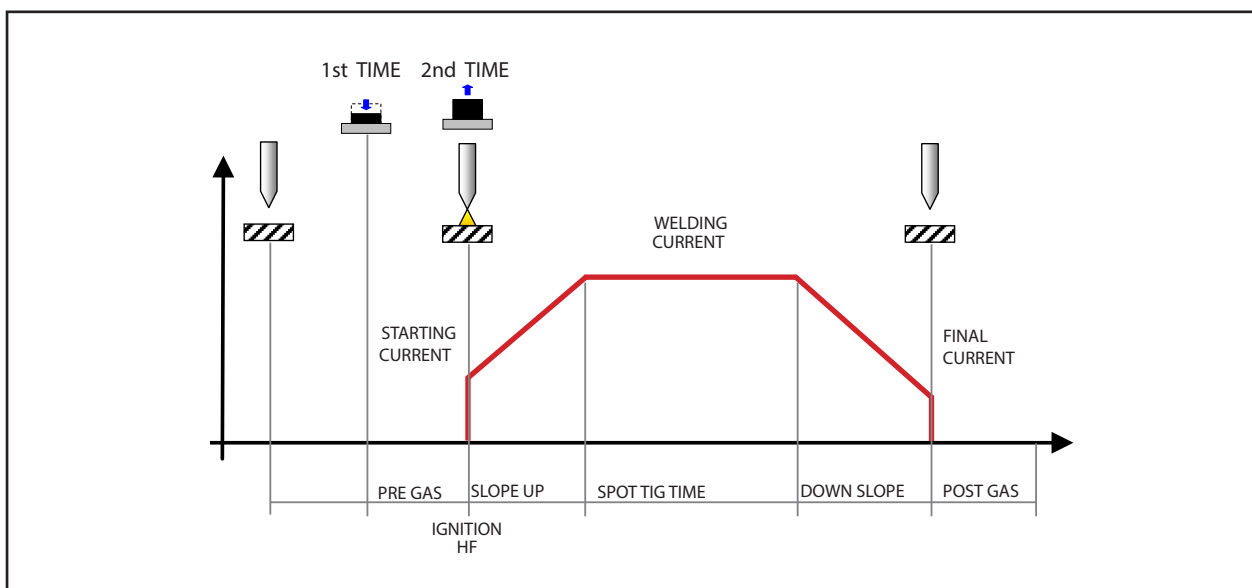

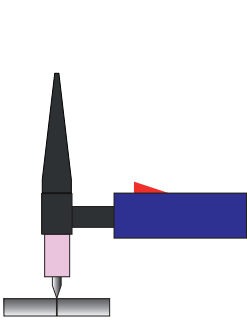
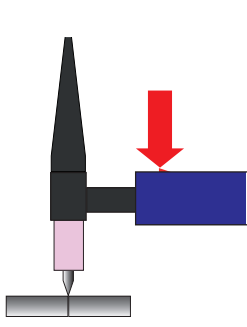
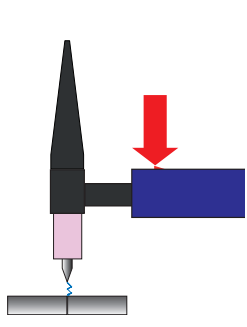
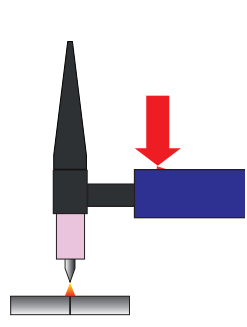
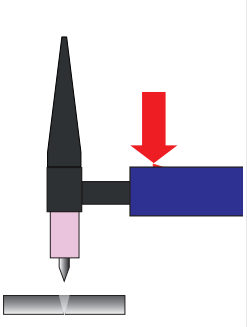
				
1. Position the torch with the electrode on the workpiece.	2. Press the torch trigger and keep it pressed.	3. Lift the torch slightly. As soon as the electrode is lifted then the HF ignition starts.	4. The arc ignites for A few hundredths of a second (time can be set up).	5. The result of this is a very precise, not oxidized welding spot without any plastic deformation of the sheet.

PROCEDURE WITH CONTINUOUS PRESSURE OF TORCH BUTTON

- Bring the torch up to the work until the electrode tip is approximately 2 or 3 mm away.
- Press (1T) the torch trigger.
- The arc strikes without contact with the workpiece and the voltage discharges (HF) cease automatically.
- The welding current reaches the pre-set value, by way of an up slope time, if programmed.
- The welding procedure continues, at the pre-set current, for the time set with the spot time parameter.
- The current reaches the end current value in the time set in the down slope time parameter.
- The arc is extinguished.
- Gas delivery continues for the time set in the post gas parameter.
- Touch the workpiece with the torch electrode.
- Slowly lift the torch to strike the arc.

The welding parameters are available in accordance with the selected welding mode and procedure. Certain parameters are available only after other parameters or functions of the unit have been enabled or set.

The table shows the settings required to enable each parameter.

















LEGEND

- √: ____ Always available.
- 1: ____ Available with the following setting: MULTI TACK = OFF
- 2: ____ Available when remote control is enabled and a remote control pedal is connected to the unit.
- 3: ____ Available with the following setting: HF STRIKE = ON
- 4: ____ Available when foot pedal controller is disabled.
- 5: ____ Available with the following setting: TYPE OF PULSED CURRENT = SLO.
- 6: ____ Available with the following setting: TYPE OF PULSED CURRENT = FA.

Meaning of symbols

1+2 = All conditions must be fulfilled (both 1 and 2).

Tab. 19 - Table showing enabled Welding Parameters

MENU ↓	MODE →										 SYN			
	PROCEDURE →					 Q-SPOT				 Q-SPOT				 Q-SPOT
	PARAMETER ↓													
1°	WELDING CURRENT	√	√	√	√	√	√	√	√	√	√	√	√	
1°	HOT-START	√												
1°	ARC-FORCE	√												
1°	PRE-GAS TIME PRE-GAS		3	3	3	3	3	3	3	3	3	3	3	
1°	STARTING CURRENT		√	√	√	√	√	√	√	√	√	√	√	
1°	UP SLOPE		√	√	√	√	√	√	√	√	√	√	√	
1°	SECOND CURRENT B-LEVEL				√			√				√		
1°	STARTING CURRENT					√	√	√	√	√	√	√	√	
1°	PEAK TIME					√	√	√	√	√	√	√	√	
1°	PULSED CURRENT FREQUENCY					6	6	6	6	6	6	6	6	
1°	BASE TIME					5	5	5	5					
1°	DOWN SLOPE		√	√	√	√	√	√	√	√	√	√	√	
1°	END CURRENT		√	√	√	√	√	√	√	√	√	√	√	
1°	POST GAS TIME		√	√	√	√	√	√	√	√	√	√	√	
2°	TYPE OF ELECTRODE	√												
2nd	VRD	√												
2°	LONG ARC VOLT-AGE	√												
2nd	SPOT-WELDING TIME				√				√				√	
2nd	HF ARC START		√	√	√	√	√	√	√	√	√	√	√	
2ND	MINIMUM PEDAL CURRENT		2			2	2			2	2		2	
2°	AC WAVEFORM													
SPECIAL	Q-START		3+1	3+1	3+1		3+1	3+1	3+1					
SPECIAL	DYNAMIC ARC		4+1	1			3+1	1						
SPECIAL	MULTI TACK		3	3			3	3			3	3		
SPECIAL	ELECTRODE DIAMETER		√	√	√	√	√	√	√	√	√	√	√	

11 JOBS MANAGEMENT

Personalised welding settings, or JOBS, can be saved in memory locations and subsequently uploaded. Up to 50 JOBS can be saved (j01-j50).

JOBS can be managed only when the unit is not in welding mode.





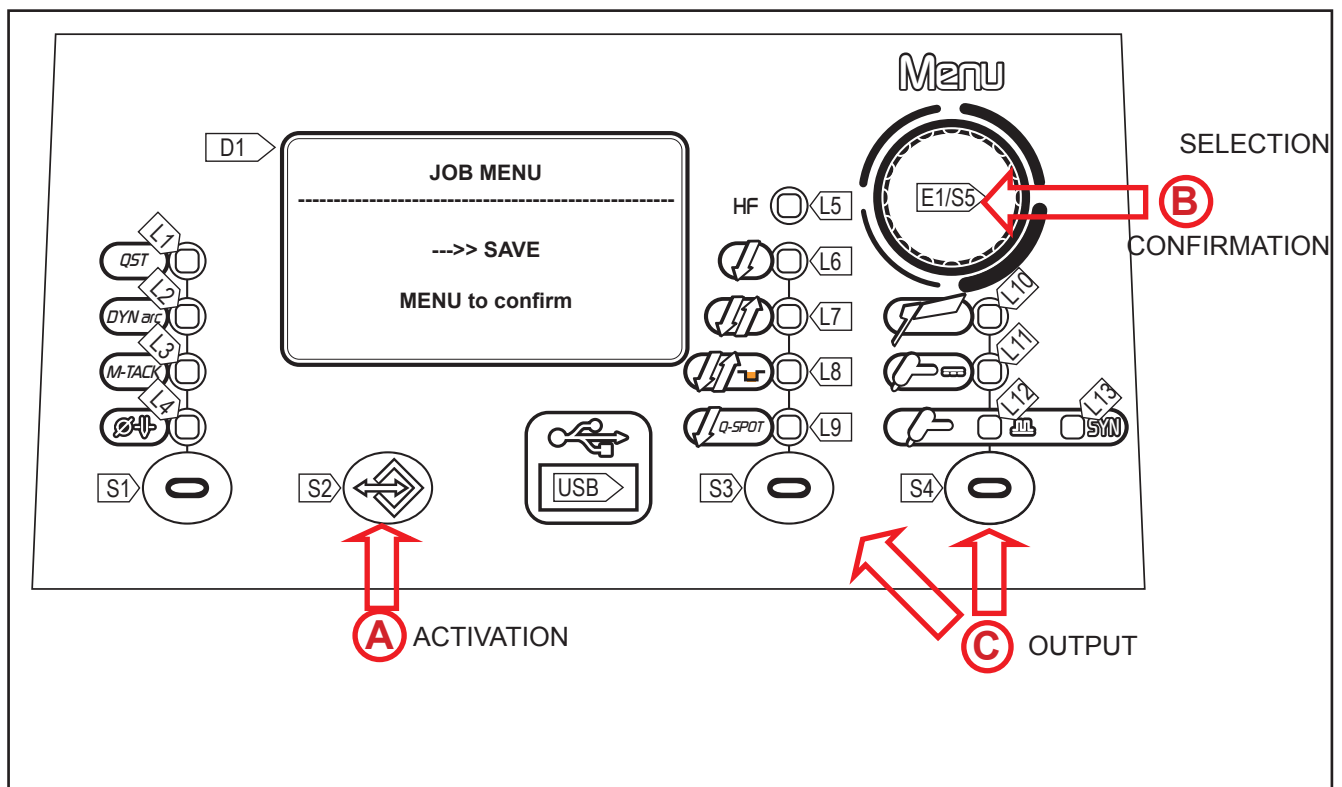

The SETUP menu settings cannot be saved by means of the JOBS.

When a JOB is loaded and an UP/DOWN torch is installed, press the torch triggers to select the saved JOBS.

If there are no JOBS loaded, the UP/DOWN buttons on the torch serve to adjust the welding current.







11.1 SAVING A JOB

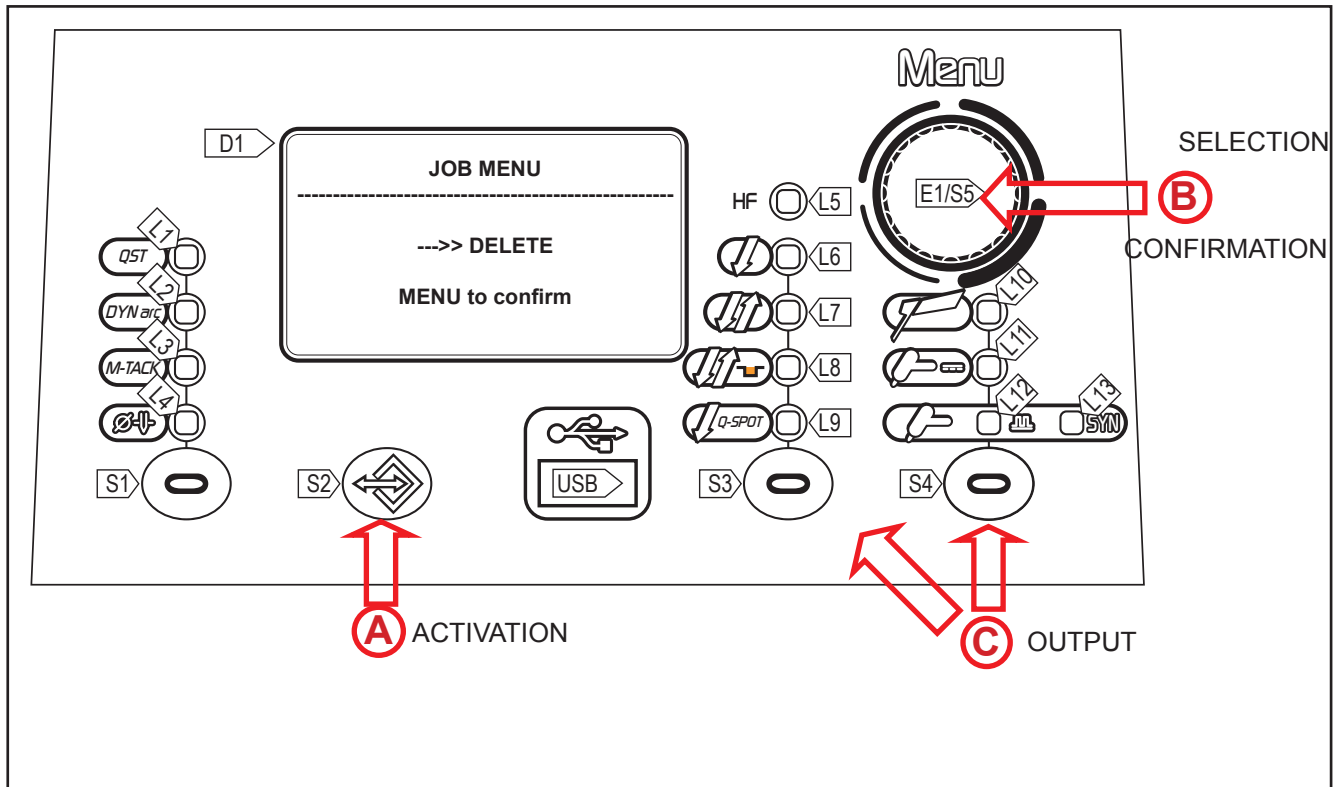

- | | |
|------------|------------------------------------------------------------------------------------------------------------------------------------------------------------------------------------------------------------------------------------------------------------------------------------------------------------------------------------------------------------------------------------------------------------------------------------------------------------------------------------------------------------------------------------------------------------------------------------------------------------------------------------------------------------------------------------------------------------------------------------------------|
| (A) | <ul style="list-style-type: none"> ○ Press the S2 button  to enter the JOB MENU. |
| (B) | <ul style="list-style-type: none"> ○ Use the encoder E1 , to select SAVE. ○ Press the S5 button  to confirm. ○ Use the encoder E1  to select the JOB position. (By selecting the number of a position where a JOB has already been saved, the job number is shown on lighted background.) ○ Press the S5 button  to confirm. |
| (C) | <ul style="list-style-type: none"> ○ Exit without confirmation <ul style="list-style-type: none"> - Press the S3/S4 button . |







11.2 DELETING A JOB

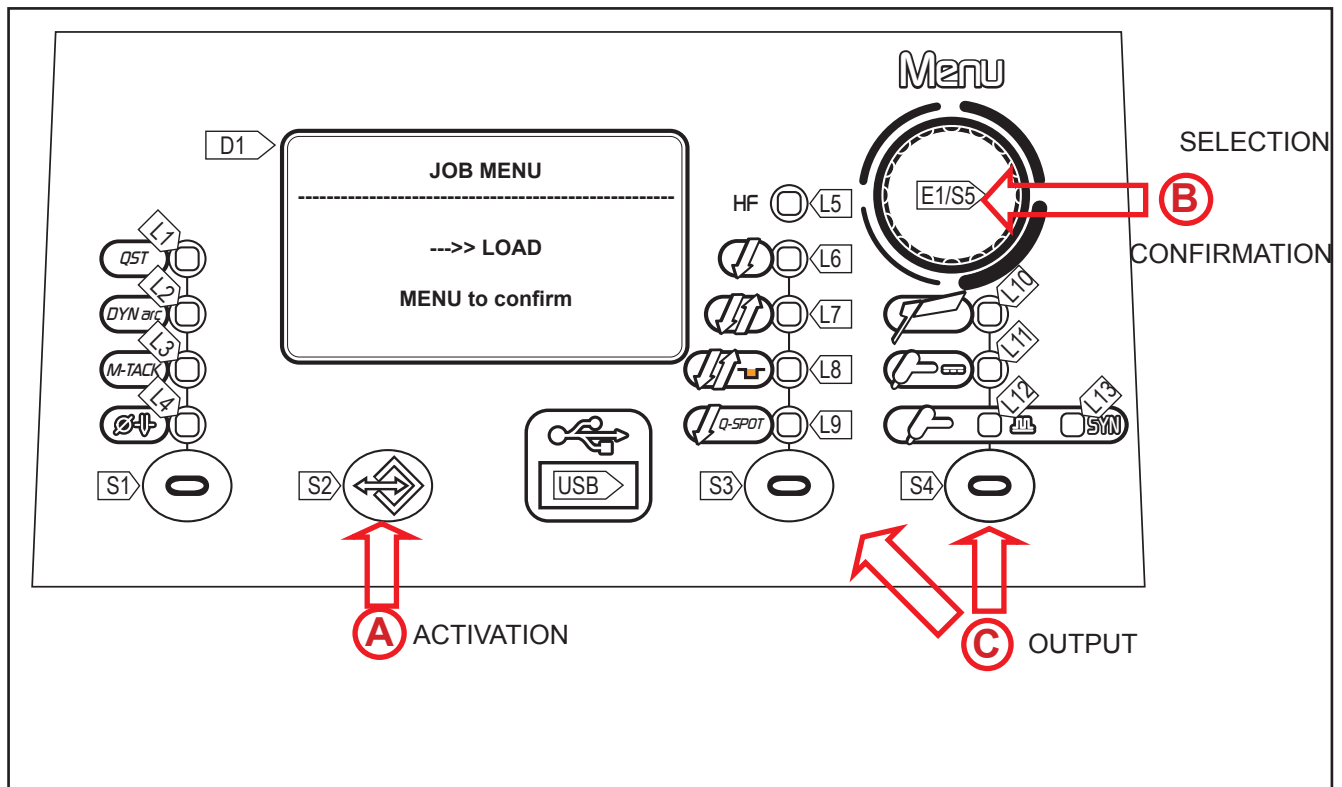

- | | |
|----------|----------------------------------------------------------------------------------------------------------------------------------------------------------------------------------------------------------------------------------------------------------------------------------------------------------------------------------------------------------------------------------------------------------------------------------------------------------------------------------------------------------------------------------------------------------------------------------------------------------------------|
| A | <ul style="list-style-type: none"> o Press the S2 button  to enter the JOB MENU. |
| B | <ul style="list-style-type: none"> o Use the encoder E1  to select DELETE. o Press the S5 button  to confirm. o Use the encoder E1  to select the JOB position. o Press the S5 button  to confirm. |
| C | <ul style="list-style-type: none"> o Exit without confirmation <ul style="list-style-type: none"> - Press the S3/S4 button . |

11.3 LOADING A JOB



- | | |
|----------|----------------------------------------------------------------------------------------------------------------------------------------------------------------------------------------------------------------------------------------------------------------------------------------------------------------------------------------------------------------------------------------------------------------------------------------------------------------------------------------------------------------------------------------------------------------------------------------------------------------------------------------------------------------|
| A | <ul style="list-style-type: none"> ○ Press the S2 button  to enter the JOB MENU. |
| B | <ul style="list-style-type: none"> ○ Use the encoder E1 , to select LOAD. ○ Press the S5 button  to confirm. ○ Use the encoder E1  to select the JOB position. ○ Press the S5 button  to confirm. (The display shows the loaded JOB number). |
| C | <ul style="list-style-type: none"> ○ Uscita senza conferma
- Premere il tasto S3/S4 . |

To quit the currently loaded JOB, change any setting on the power source user interface.

11.4 EXPORTING/IMPORTING JOBS (through a USB memory stick)

By using a USB memory stick, the JOBS saved on the panel can be exported and imported into another panel.

When a USB memory stick is connected, the JOB MENU will display the items related to the importing and exporting procedure.



WARNING! The JOBS are exported to the USB memory stick with the name of the location where they are saved on the panel. If the file names of the JOBS saved onto the USB memory stick are changed by using a PC, after they are imported into the destination panel, they will still be saved in their original location. This means that, if the destination panel already contains JOBS saved in the same location as those exported to the memory stick, they will be overwritten.

We recommend not to change the name of the files exported to the USB memory stick. The file extension (.bin) must never be changed.

JOBS to be kept must be moved in a location of the destination panel different from the location of the JOBS exported to the USB memory stick.

To be usable, the memory stick must be formatted as FAT32.

The JOBS are interchangeable only among the same type of power sources and as long as their software versions are compatible.

EXPORTING A JOB

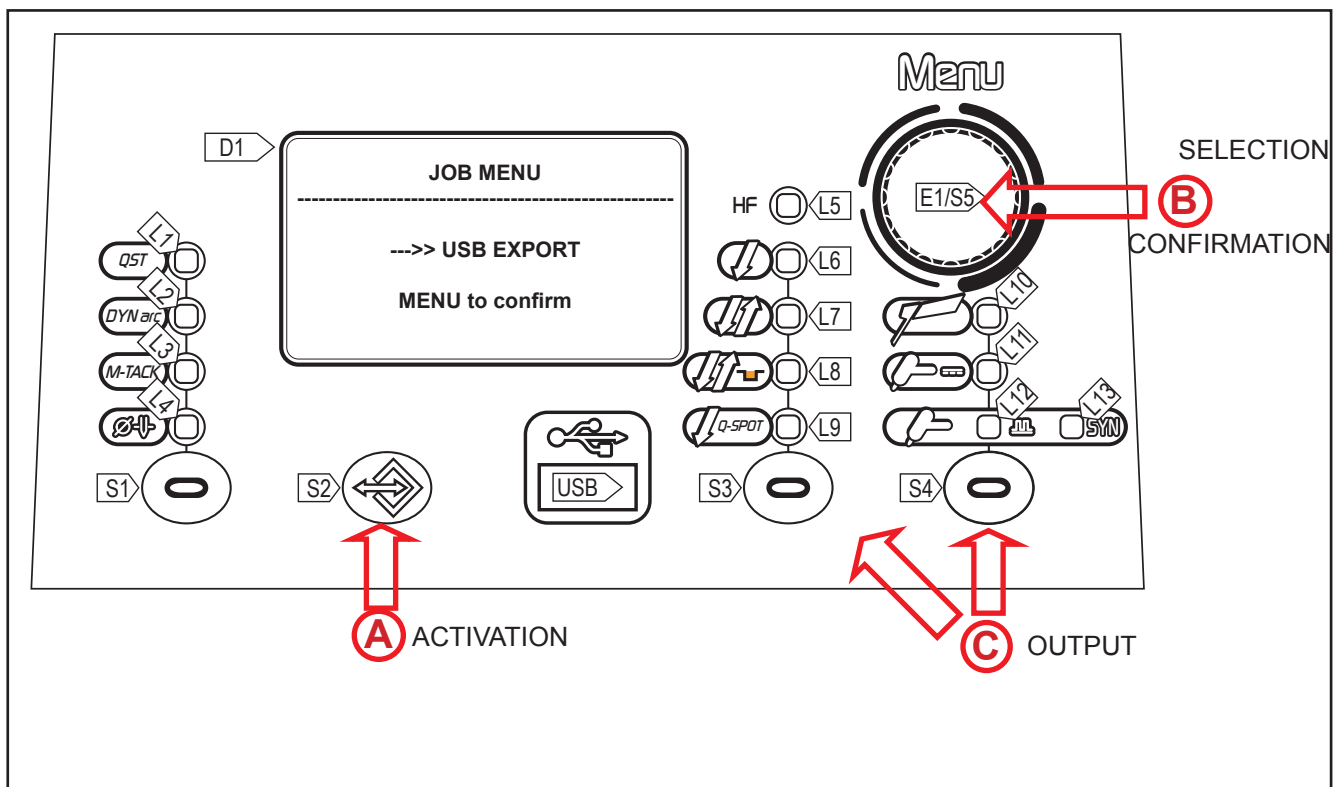

- A** ○ Insert the memory stick in the USB port
- Press the S2 button  to enter the JOB MENU.

- B
 - Use the **encoder E1** , to select USB EXPORT.
 - Press the **S5** button to confirm.
 - Wait for the JOB export procedure to terminate.
- C
 - **Uscita**
 - Press the **S3/S4** button .



Tab. 20 - JOB exporting operation messages

MESSAGGIO	SIGNIFICATO	VERIFICHE
USB DEVICE NOT FOUND	USB device not found	- incorrectly inserted memory stick. - memory stick removed before completing the operation.
EXPORT FAILED	Exporting procedure failed.	- USB not formatted as FAT32. - unidentifiable generic error: re-insert the memory stick and retry. - the connected USB drive is damaged.
EXPORT IN PROGRESS	The JOBS saved on the panel are being exported	
EXPORT COMPLETE	Exporting procedure completed	

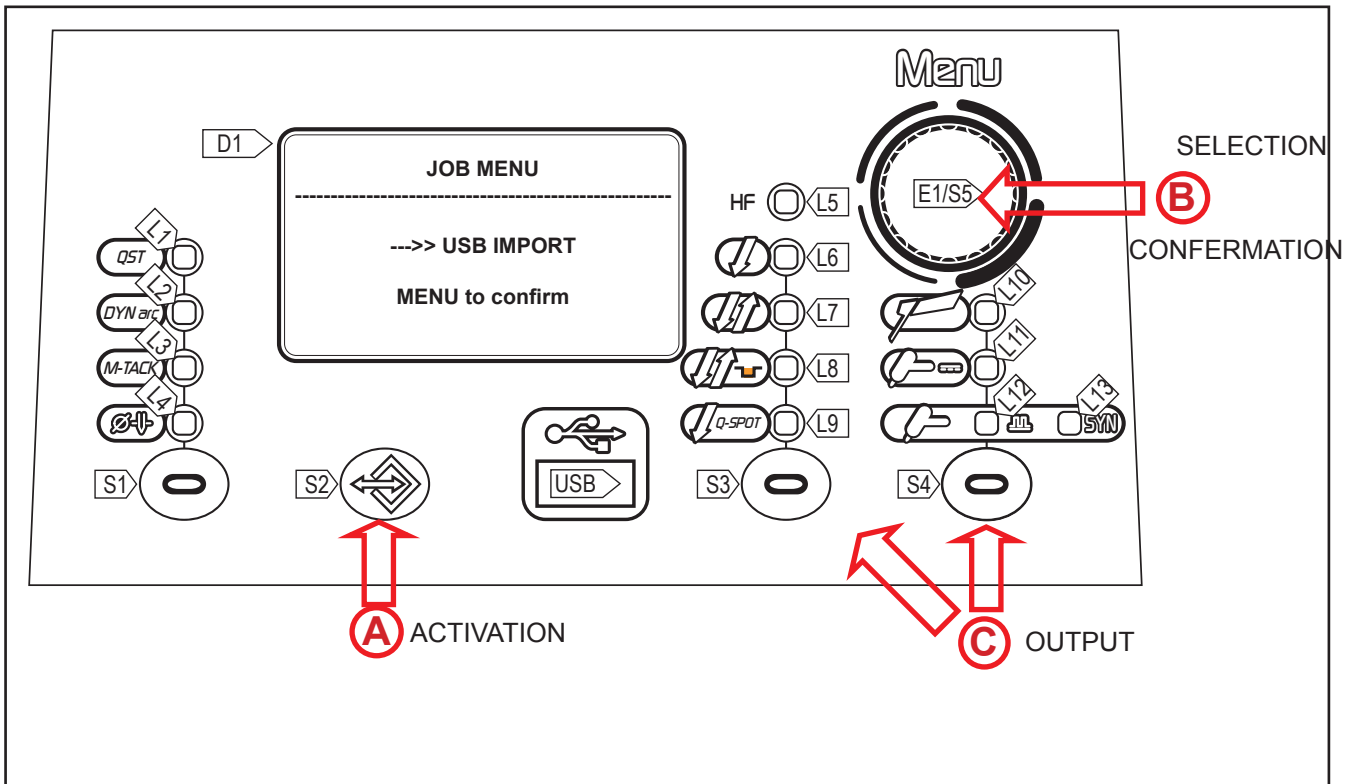
IMPORTING A JOB



- A
 - Insert the memory stick in the USB port
 - Press the **S2** button to enter the JOB MENU.

- B
 - Use the **encoder E1**  to select USB IMPORT.
 - Press the **S5** button  to confirm.
 - Wait for the JOB import procedure to terminate.
 - If no valid JOB file is present, the “IMPORT FAILED” message is displayed
- C
 - **Exit**
 - Press the **S3/S4** button .

Tab. 21 - JOB importing operation messages

MESSAGGIO	SIGNIFICATO	VERIFICHE
USB DEVICE NOT FOUND	USB device not found	- incorrectly inserted memory stick - memory stick removed before completing the operation
FILE NOT FOUND	File not found	- there are no JOBS loaded onto the USB memory stick.
IMPORT FAILED	Importing procedure failed.	- USB not formatted as FAT32. - unidentifiable generic error: re-insert the memory stick and retry. - the connected USB drive is damaged.
IMPORT IN PROGRESS	The JOBS saved on the USB memory stick are being imported	
IMPORT COMPLETE	Importing procedure completed	

11.5 SELECTING JOBS USING THE TORCH BUTTONS

When an UP/DOWN torch is installed, JOBS can be selected in a JOB sequence using the buttons on the welding torch. To create the JOB sequence, leave a free memory slot before and after the group of JOBS to be included in the sequence.





To create the JOB sequence, leave a free memory slot before and after the group of JOBS to be included in the sequence.

Sequence 1			JOB not saved	Sequence 2			JOB not saved	Sequence 3		
J.01	J.02	J.03		J.05	J.06	J.07		J.09	J.10	J.11



Select and upload one of the JOBS belonging to the desired sequence (e.g. J.06) through the power source user interface.

Use the torch buttons to scroll through the JOBS of sequence 2 (J.05, J.06, J.07).



12 TECHNICAL DATA

Directives applied	Waste electrical and electronic equipment (WEEE)
	Electromagnetic compatibility (EMC)
	Low voltage (LVD)
	Restriction of the use of certain hazardous substances (RoHS)
Construction standards	EN 60974-1; EN 60974-3; EN 60974-10 Class A
Conformity markings	 Equipment compliant with European directives in force
	 Equipment suitable in an environment with increased hazard of electric shock
	 Equipment compliant with WEEE directive
	 Equipment compliant with RoHS directive

12.1 DISCOVERY 220T Evo/VRD Evo

Supply voltage	1 x 230V ~± 15 % / 50-60 Hz		
Mains protection	16 A Delayed		
Zmax	Compliant with EN 61000-3-12 Hook-up not dependent on the supply network		
Dimensions (L x D x H)	460 x 230 x 325 mm		
Weight	18.6 kg		
Insulation class	H		
Protection rating	IP23S		
Cooling	AF: Air-over cooling (fan assisted)		
Maximum gas pressure	0,5 MPa (5 bar)		
Static characteristic	MMA	 Falling characteristic	
	TIG	 Falling characteristic	
Welding mode		MMA	TIG
Current and voltage adjustment range		10 A / 20.4 V 180 A - 27.2 V	5 A / 10.2 V 220 A - 18.8 V
Welding current / Working voltage	40% (40° C)	--	220 A - 18.8 V
	60% (40° C)	180 A - 27.2 V	190 A - 17.6 V
	100% (40° C)	150 A - 26.0 V	160 A - 16.4 V
Maximum input power	40% (40° C)	--	5.2 KW
	60% (40° C)	5.8 KW	4.2 KW
	100 % (40° C)	4.5 KW	3.3 KW
Maximum supply current	40% (40° C)	--	22.9 A
	60% (40° C)	25.7 A	18.4 A
	100 % (40° C)	20.2 A	14.4 A
Maximum Effective Supply Current	40% (40° C)	--	14.5A
	60% (40° C)	19.9A	14.2A
	100 % (40° C)	20.2A	14.4A
No-load voltage (U0)	81 V		
Reduced no-load voltage (Ur)	5 V		
Rated HF peak voltage (Up)	13.5 kV Arc striking device designed to work with manual guided torch.		
Power source efficiency	Efficiency (180A / 27.2V): 82.7%		
	No-Load condition power consumption (U1= 230 Va.c.): 32 W		
Essential raw materials	According to the information provided by our suppliers, this product does not contain essential raw materials in quantities greater than 1g per component.		

12.2 DISCOVERY 300T Evo/VRD Evo

Supply voltage	3 x 400 Va.c. ± 15 % / 50-60 Hz		
Mains protection	20 A Delayed		
Zmax	This equipment complies with IEC 61000-3-12 provided that the maximum permissible system impedance is less than or equal to 38 mΩ at the interface point between the user's supply and the public system. It is the responsibility of the installer or user of the equipment to ensure, by consultation with the distribution network operator if necessary, that the equipment is connected only to a supply with maximum permissible system impedance less than or equal to 38 mΩ		
Dimensions (L x D x H)	460 x 230 x 325 mm		
Weight	22.0 kg		
Insulation class	H		
Protection rating	IP23S		
Cooling	AF: Air-over cooling (fan assisted)		
Maximum gas pressure	0,5 MPa (5 bar)		
Static characteristic	MMA	 Falling characteristic	
	TIG	 Falling characteristic	
Welding mode		MMA	TIG
Current and voltage adjustment range		10 A / 20.4 V 300 A / 32.0 V	5 A / 10.2 V 300 A / 22.0 V
Welding current / Working voltage	40% (40° C)	300 A / 32.0 V	300 A / 22.0 V
	60% (40° C)	230 A / 29.2 V	250 A / 20.0 V
	100% (40° C)	200 A / 28.0 V	210 A / 18.4 V
Maximum input power	40% (40° C)	13.3 kVA – 10.7 kW	10.3 kVA – 7.9 kW
	60% (40° C)	9.9 kVA – 7.9 kW	8.4 kVA – 6.2 kW
	100 % (40° C)	8.4 kVA – 6.6 kW	6.7 kVA – 4.8 kW
Maximum supply current	40% (40° C)	19.1 A	14.8 A
	60% (40° C)	14.3 A	12.2 A
	100 % (40° C)	12.3 A	9.4 A
Maximum Effective Supply Current	40% (40° C)	12.0 A	10.4 A
	60% (40° C)	11.0 A	9.5 A
	100 % (40° C)	12.3 A	9.4 A
No-load voltage (U0)	76V		
Reduced no-load voltage (Ur)	9V		
Rated HF peak voltage (Up)	13.5 kV Arc striking device designed to work with manual guided torch.		
Power source efficiency	Efficiency (300A / 32V): 85%		
	No-Load condition power consumption (U1= 400 Va.c.): 20 W		
Essential raw materials	According to the information provided by our suppliers, this product does not contain essential raw materials in quantities greater than 1g per component.		

13 ELECTRICAL DIAGRAM

13.1 DISCOVERY 220T Evo/VRD Evo

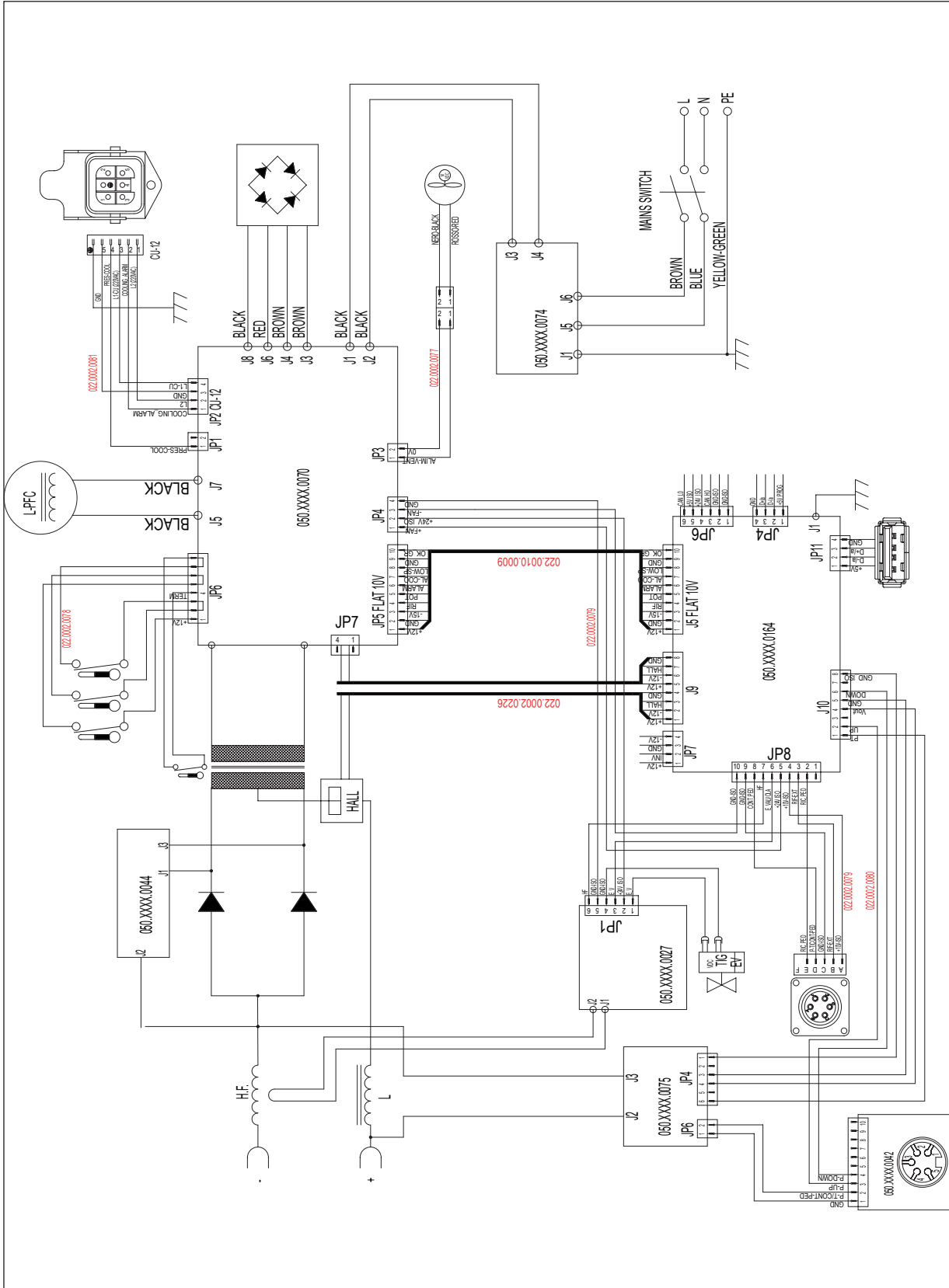

13.2 DISCOVERY 300T Evo/VRD Evo

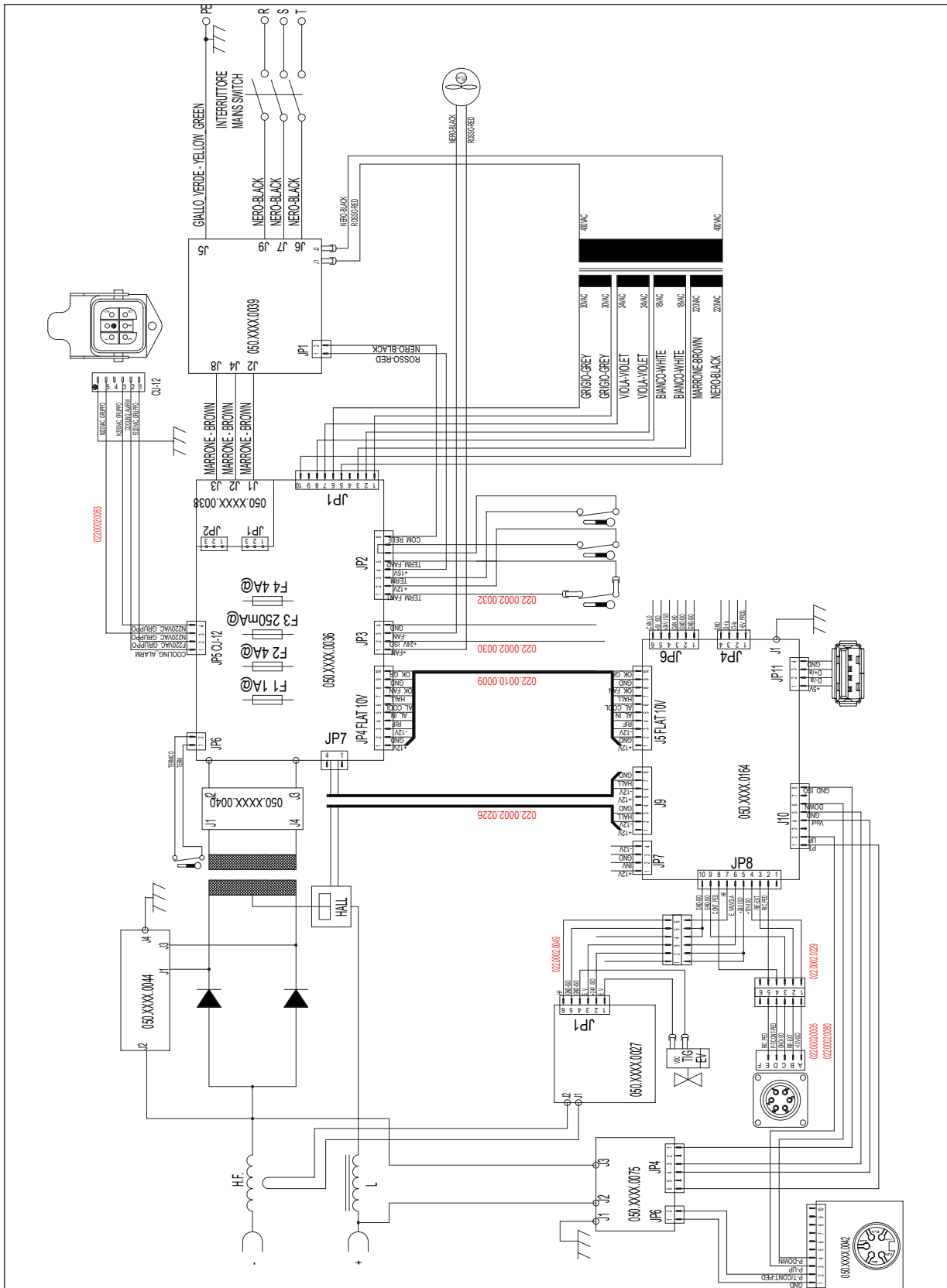

13.3 TORCH CONNECTOR (front panel)

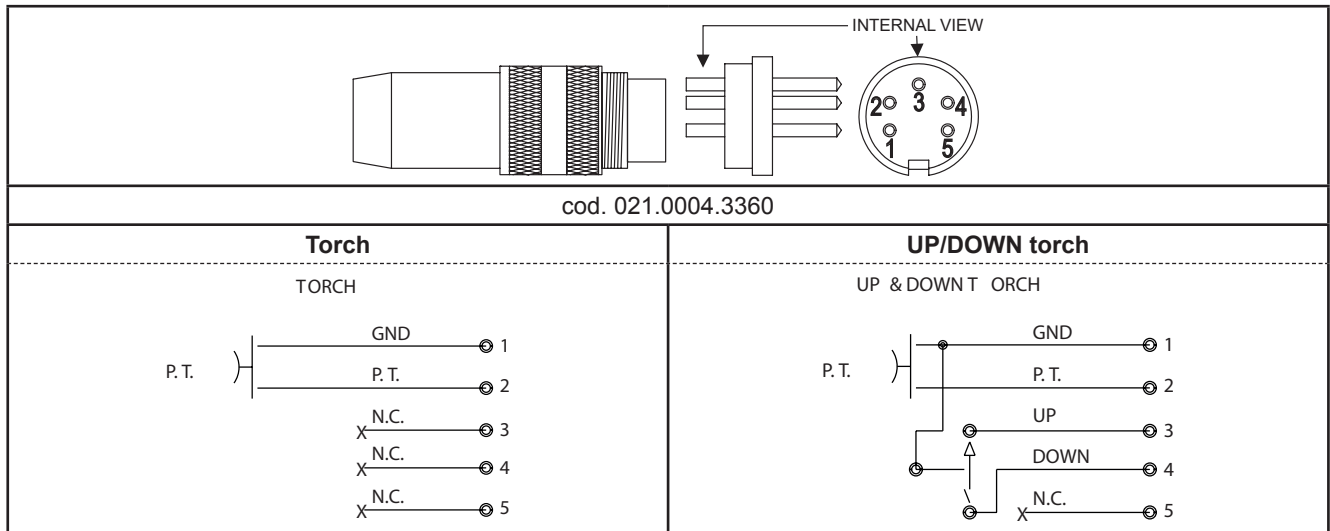

13.4 REMOTE CONTROL CONNECTOR (back panel)

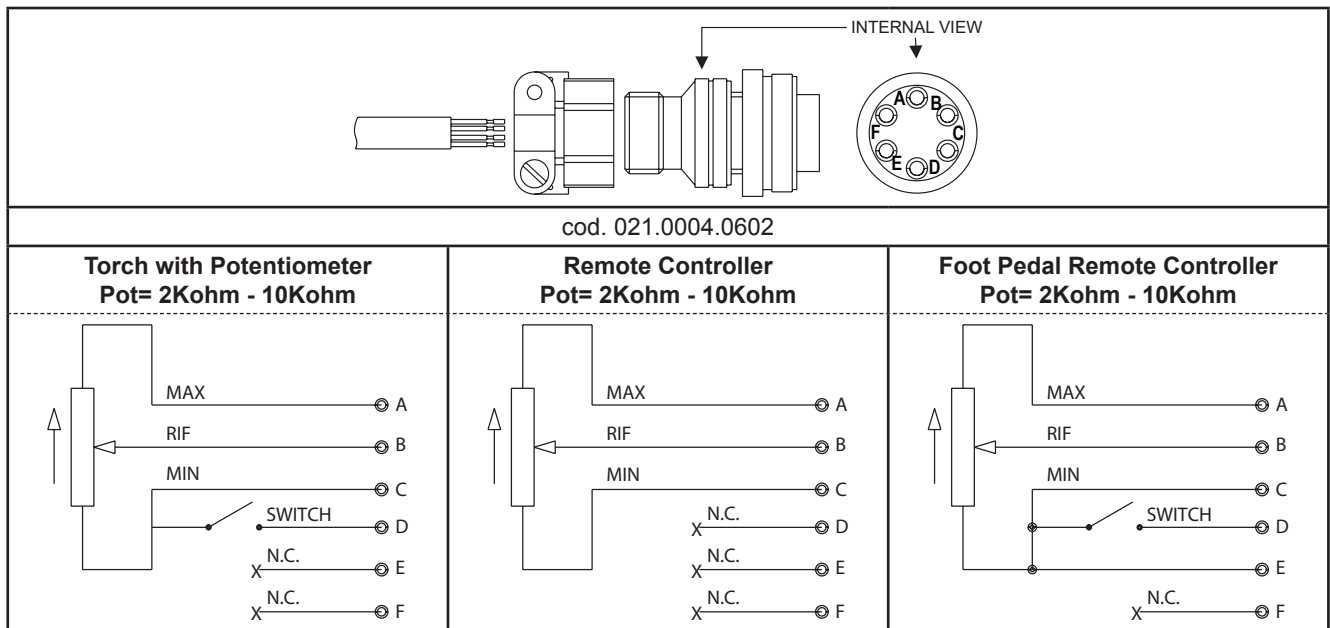

14 SPARE PARTS

14.1 DISCOVERY 220T Evo/VRD Evo

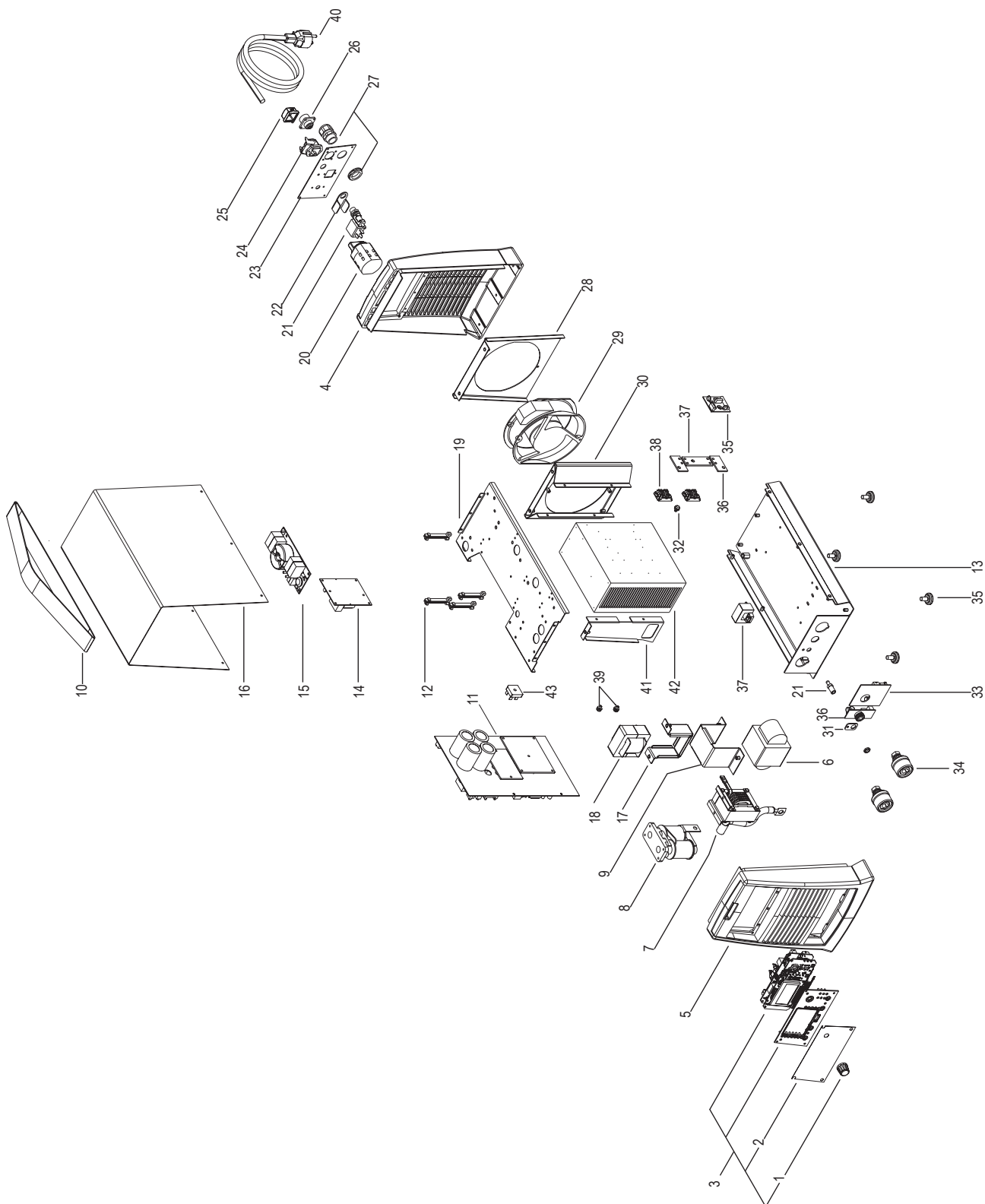

N°	CODE	DESCRIPTION
1	014.0002.0002	KNOB
2	013.0011.1401	FRONT PANEL LABEL (220T EVO) (220T-VRD EVO)
3	050.5170.0000	COMPLETE LOGIC FRONT PANEL (220T EVO)
	050.5180.0000	COMPLETE LOGIC FRONT PANEL (220T-VRD EVO)
4	010.0006.0034	REAR PLASTIC PANEL
5	010.0006.0033	FRONT PLASTIC PANEL
6	042.0003.0034	POWER TRANSFORMER
7	044.0004.0025	OUTPUT INDUCTANCE
8	010.0002.0004	HF TRANSFORMER
9	011.0002.0012	TRANSFORMER SUPPORT
10	005.0001.0008	BELT
11	050.0002.0070	POWER BOARD
12	016.0010.0001	BOARD SUPPORT GUIDE
13	011.0008.0001	LOWER COVER
14	050.0003.0027	HF BOARD
15	050.0001.0074	LINE FILTER BOARD
16	011.0000.0161	UPPER COVER
17	011.0003.0057	BOOST INDUCTANCE SUPPORT
18	044.0004.0017	BOOST INDUCTANCE
19	011.0008.0020	UPPER PLATE
20	040.0001.0011	BI-POLE SWITCH
21	017.0001.5542	SOLENOID VALVE
22	011.0002.0018	SOLENOID VALVE PLATE
23	013.0012.0500	REAR PANEL
24	022.0002.0081	COOLING UNIT SUPPLY CABLE
25	021.0013.0007	ILME CONNECTOR CAP
26	022.0002.0079	REMOTE CONTROL WIRING
27	045.0000.0007	CABLE CLAMP
28	011.0008.0010	EXTERNAL FAN SUPPORT
29	003.0002.0004	FAN
30	011.0008.0011	INTERNAL FAN SUPPORT
31	011.0002.0036	SOLENOID VALVE BLOCK
32	040.0003.1003	TERMAL SWITCH L=290mm 75°C
33	050.0001.0075	OUTPUT FILTER BOARD
34	021.0001.0259	COMPLETE FIXED SOCKETS 400A
35	016.0009.0003	RUBBER FOOT
36	050.0001.0076	AMPHENOL CONN. BOARD
37	041.0004.0301	HALL SENSOR
38	032.0002.2403	DIODE
39	040.0003.1002	TERMAL SWITCH L=200mm 75°C
40	045.0002.0008	SUPPLY CABLE
41	011.0008.0029	LATERAL PLATE
42	015.0001.0006	HEAT SINK
43	032.0001.3506	PRIMARY RECTIFIER

14.2 DISCOVERY 300T Evo/VRD Evo

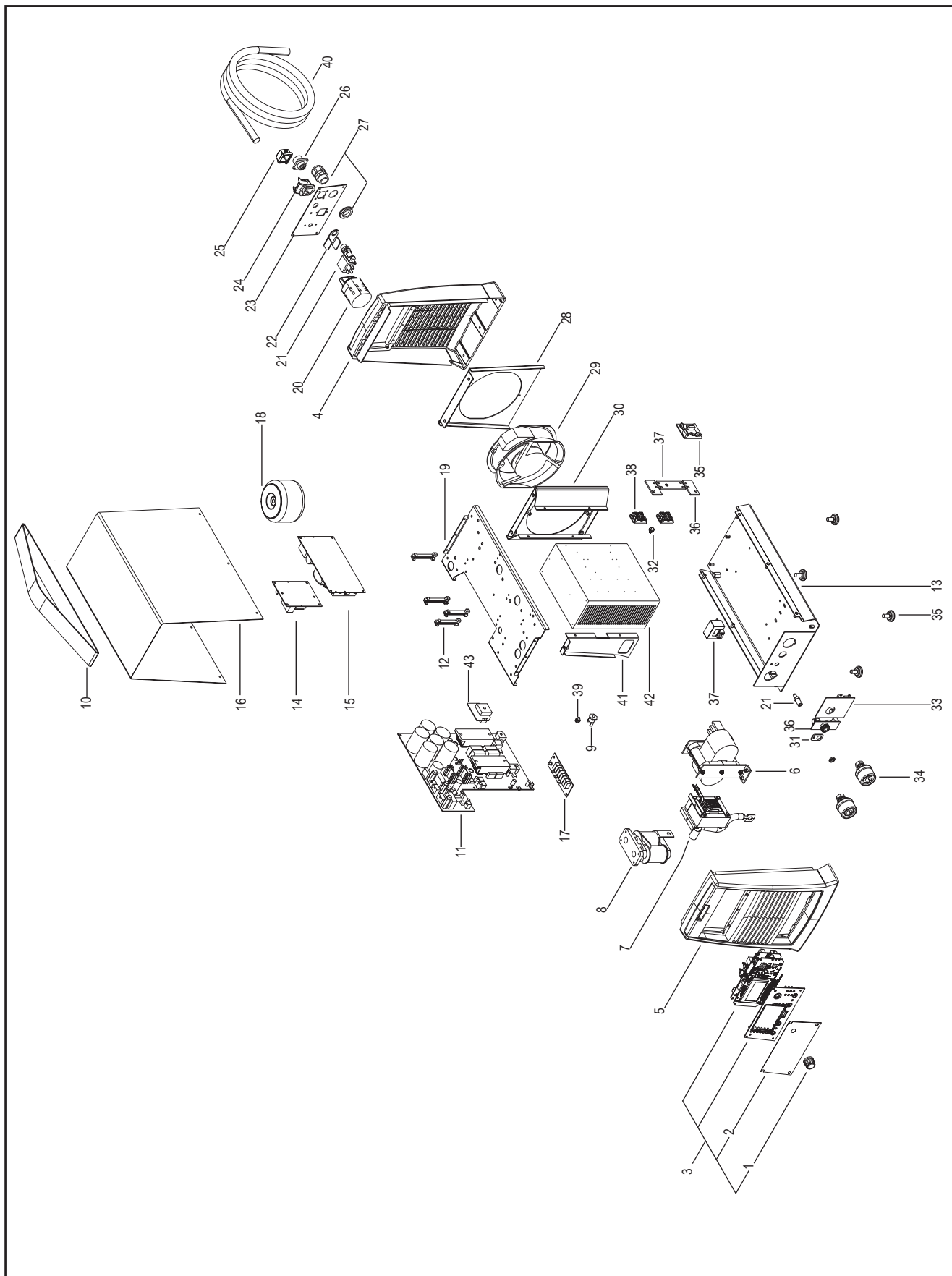

N°	CODE	DESCRIPTION
1	014.0002.0002	KNOB
2	013.0011.1501	FRONT PANEL LABEL (300T EVO) (300T-VRD EVO)
3	050.5172.0000	COMPLETE LOGIC FRONT PANEL (300T EVO)
	050.5182.0000	COMPLETE LOGIC FRONT PANEL (300T-VRD EVO)
4	010.0006.0034	REAR PLASTIC PANEL
5	010.0006.0033	FRONT PLASTIC PANEL
6	042.0003.0032	POWER TRANSFORMER
7	044.0004.0025	OUTPUT INDUCTANCE
8	010.0002.0004	HF TRANSFORMER
9	040.0003.0060	TERMAL SWITCH 60°C
10	005.0001.0008	BELT
11	050.0003.0036	POWER BOARD
12	016.0010.0001	BOARD SUPPORT GUIDE
13	011.0008.0001	LOWER COVER
14	050.0003.0027	HF BOARD
15	050.0001.0074	LINE FILTER BOARD
16	011.0000.0161	UPPER COVER
17	050.0001.0119	PRIMARY CAPACITOR BOARD
18	041.0006.0010	AUXILIARY TRANSFORMER
19	011.0008.0021	UPPER PLATE
20	040.0001.0017	THREE-POLE SWITCH
21	017.0001.5542	SOLENOID VALVE
22	011.0002.0018	SOLENOID VALVE PLATE
23	013.0012.1500	REAR PANEL
24	022.0002.0083	COOLING UNIT SUPPLY CABLE
25	021.0013.0007	ILME CONNECTOR CAP
26	022.0002.0005	REMOTE CONTROL WIRING
27	045.0000.0050	CABLE CLAMP
28	011.0008.0010	EXTERNAL FAN SUPPORT
29	003.0002.0003	FAN
30	011.0008.0011	INTERNAL FAN SUPPORT
31	011.0002.0036	SOLENOID VALVE BLOCK
32	040.0003.1170	TERMAL SWITCH L=290mm 75°C
33	050.0001.0075	OUTPUT FILTER BOARD
34	021.0001.0259	COMPLETE FIXED SOCKETS 400A
35	016.0009.0003	RUBBER FOOT
36	050.0001.0042	AMPHENOL CONN. BOARD
37	041.0004.0301	HALL SENSOR
38	032.0002.2403	DIODE
39	040.0003.1270	TERMAL SWITCH L=200mm 75°C
40	045.0002.0019	SUPPLY CABLE
41	011.0008.0029	LATERAL PLATE
42	015.0001.0006	HEAT SINK

N°	CODE	DESCRIPTION
43	050.0003.0038	DIODE BRIDGE BOARD

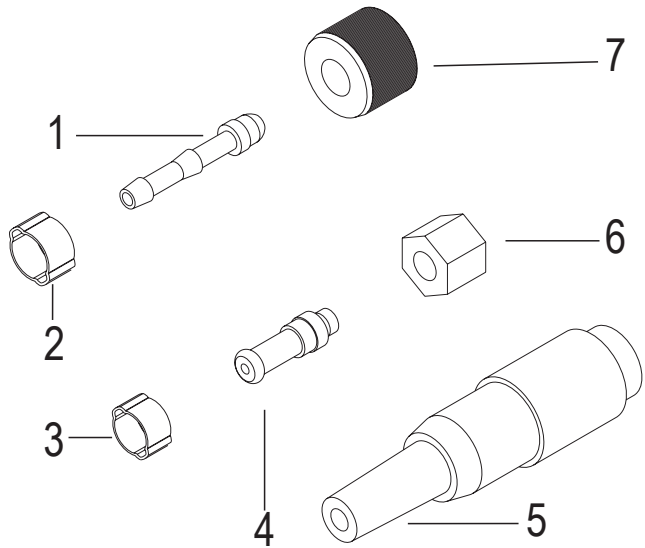

N°	CODE	DESCRIPTION
	021.0000.0001	TORCH CONNECTORS COMPLETE KIT
1	016.5001.0822	SLEEVE HOSE ADAPTER FOR RUBBER HOSE
2	016.0007.0001	HOSE CLAMP Ø=11-13
3	016.0007.0709	HOSE CLAMP Ø=07-09
4	016.5001.0821	SLEEVE HOSE ADAPTER FOR RUBBER HOSE M10
5	021.0004.3360	AMPHT3360-001 M/5V. VOL. CON-NECTOR
6	016.5001.1311	NUT M10
7	016.5001.0823	NUT 1/4



WELD THE WORLD



WELD THE WORLD

www.weco.it

