



WELD THE WORLD

CU-09
CU-09-HP
CU-09F

Instruction Manual







INDEX

1	INTRODUCTION.....	4
1.1	PRESENTAZIONE	4
2	INSTALLATION	5
2.1	FRONT PANEL	5
2.2	REAR PANEL.....	6
2.3	ASSEMBLY WITH THE WELDING POWER SOURCE	7
2.4	CU-09F BYPASS	9
3	TECHNICAL DATA	10
3.1	CU-09/CU-09F	10
3.2	CU-09-HP.....	10
4	SPARE PARTS	12
4.1	CU-09 / CU-09-HP	12
4.2	CU-09F.....	14
4.3	COUPLINGS KIT ALREADY ASSEMBLED	17
5	ELECTRICAL DIAGRAM	18

1 INTRODUCTION

 	IMPORTANT!
<p><i>This handbook must be consigned to the user prior to installation and commissioning of the unit. Read the “General prescriptions for use” handbook supplied separately from this handbook before installing and commissioning the unit.</i></p> <p><i>The meaning of the symbols in this manual and the associated precautionary information are given in the “General prescriptions for use”.</i></p> <p><i>If the “General prescriptions for use” are not present, it is mandatory to request a replacement copy from the manufacturer or from your dealer.</i></p> <p><i>Retain these documents for future consultation.</i></p>	

KEY

	DANGER!
<p><i>This pictogram warns of danger of death or serious injury.</i></p>	

	WARNING!
<p><i>This pictogram warns of a risk of injury or damage to property.</i></p>	

	CAUTION!
<p><i>This pictogram warns of a potentially hazardous situation.</i></p>	

	INFORMATION!
<p><i>This pictogram gives important information concerning the execution of the relevant operations.</i></p>	

NOTES

The figures in this manual are purely guideline and the images may contain differences with respect to the actual equipment to which they refer.

1.1 PRESENTAZIONE

The cooling unit CU-09/ CU-09-HP can be connected to the generator, allowing the liquid cooling of the TIG torch.

The CU-09 cooling unit is fitted with a pressure switch provided to detect fluid in the cooling circuit.

The CU-09F cooling unit is fitted with a pressure switch provided to detect fluid flowing in the cooling circuit.

2 INSTALLATION

2.1 FRONT PANEL

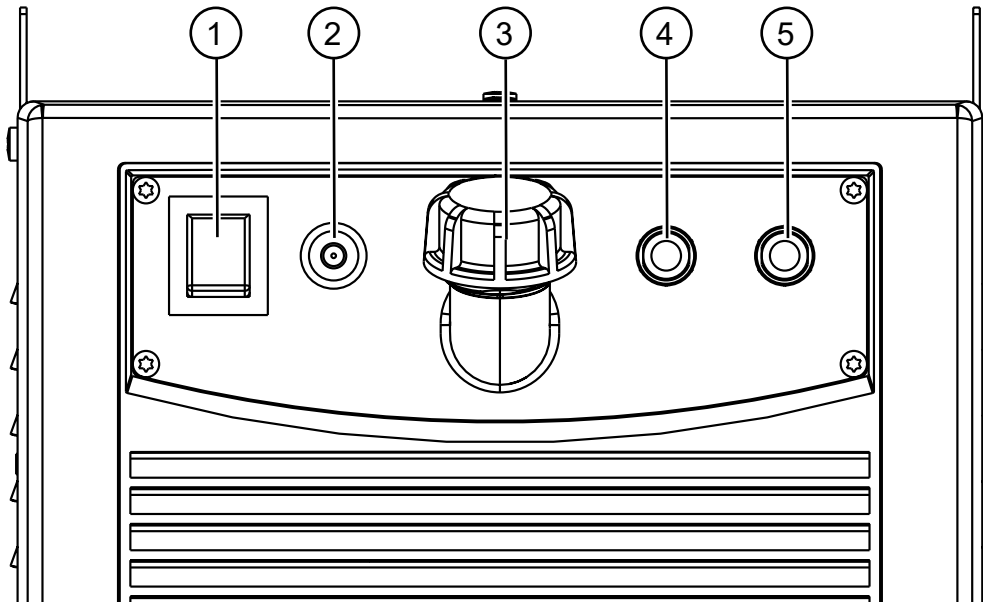

1. Switch for switching on and off.
2. Fuse.
 - Type: Delayed acting (T)
 - Amperage: 1.6 A
 - Voltage: 500 V a.c.
3. Inlet for jerrycan filling.
4. Connector for coolant hose:
power source → cooler
5. Connector for coolant hose:
cooler → power source

2.2 REAR PANEL

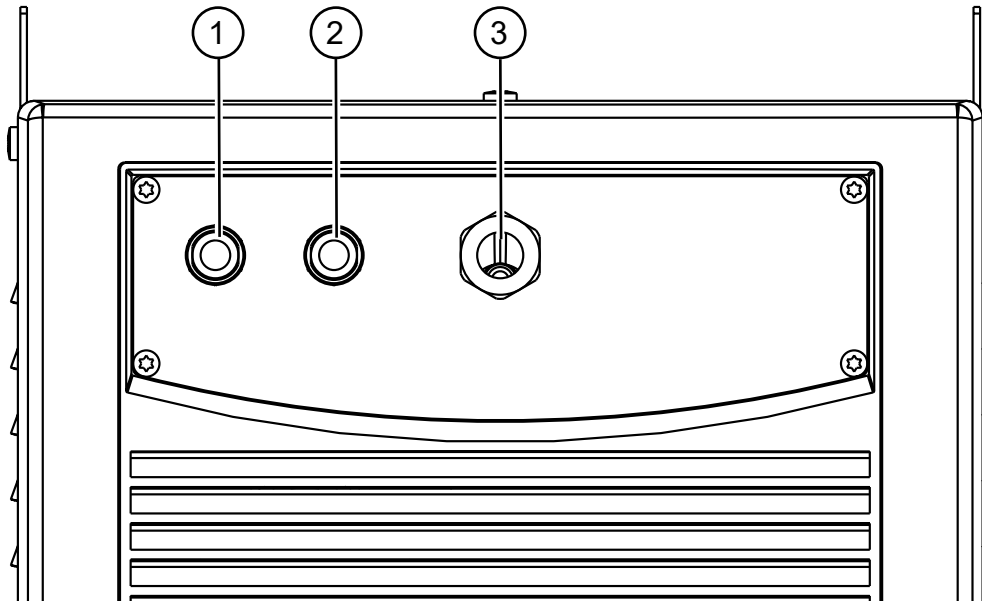

1. Connector for coolant hose:
power source → cooler
2. Connector for coolant hose:
cooler → power source
3. Power cable.
 - Total length (including internal part): 1,5 m
 - Number and cross section of wires: 5 x 1 mm²
 - Power plug type: ILME 16 A 230 / 400 Va.c.

2.3 ASSEMBLY WITH THE WELDING POWER SOURCE

DANGER!
Lifting and positioning

Read the warnings highlighted by the following symbols in the "General prescriptions for use".



1. Set the welding power source ON/OFF switch to "O" (unit de-energized).
2. Remove the screws from the power source cabinet.

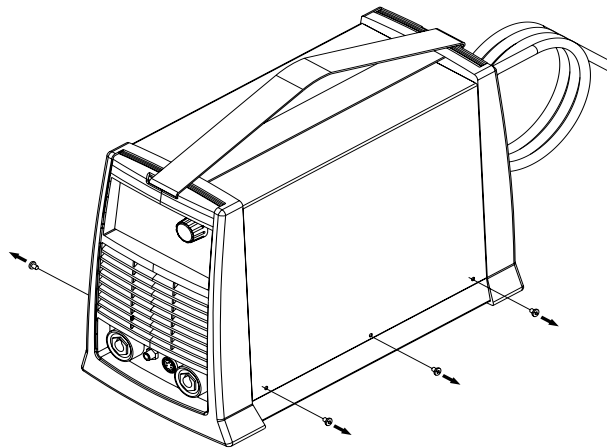

INFORMATION!

Ensure the brackets are suitable for fitting to the power source profile by means of screws.

CLAMPING PLATE
CODE: 011.0009.0034

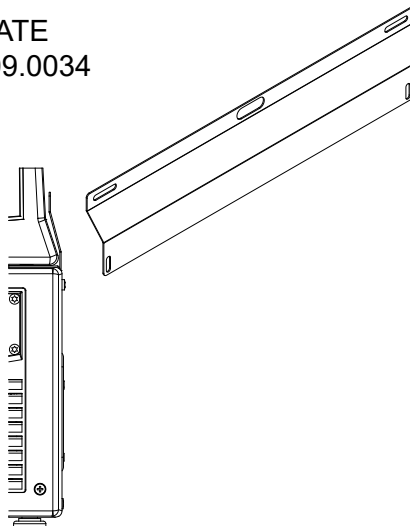

CLAMPING PLATE
CODE: 011.0012.0107

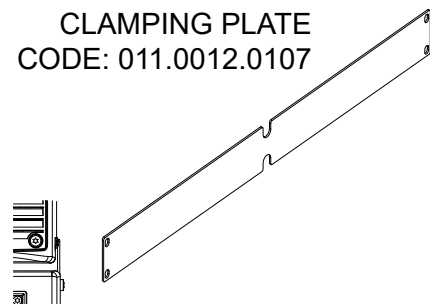

3. Loosen the screws of the upper brackets of the cooler and open out the brackets slightly.

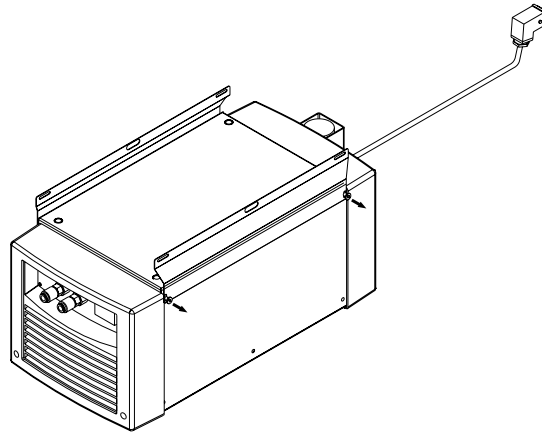

4. Place the power source on top of the cooler.
5. Secure the cooler brackets to the power source using the previously removed screws.

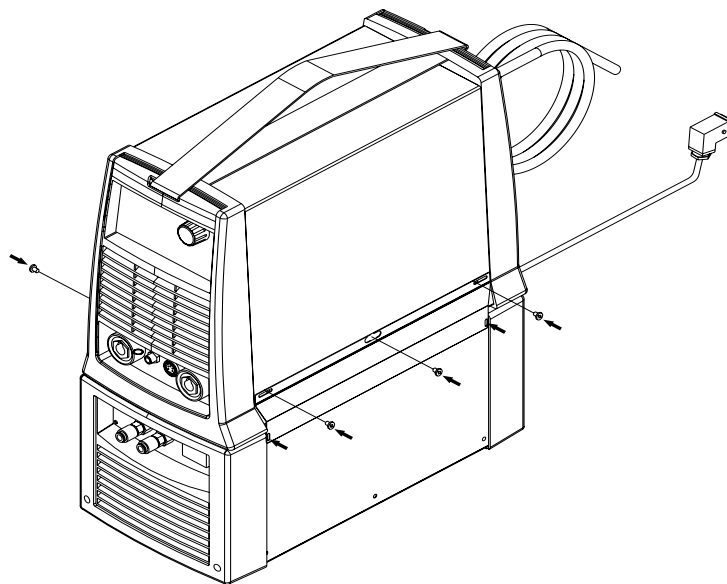

6. Connect the plug of the cooler power cable to the cooler power socket on the rear panel of the welding power source.
7. Plug the power cable plug into a mains socket outlet.
8. Set the welding power source ON/OFF switch to "I" to switch on the unit.
9. Set the cooler ON/OFF switch to "I" (unit powered).



WARNING!

*Periodically checking the level of the liquid in the indicator on the side of the cooling unit.
Be careful when choosing the cooling liquid: it must not be an electricity conductor.
Do not use polypropylene liquids because they damage the seals and generate incrustations.
Read the warnings highlighted by the following symbols in the "General prescriptions for use".*



2.4 CU-09F BYPASS



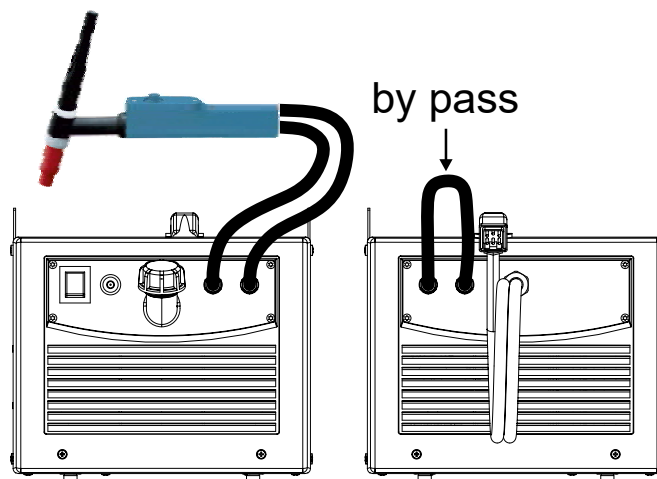

TIG configuration

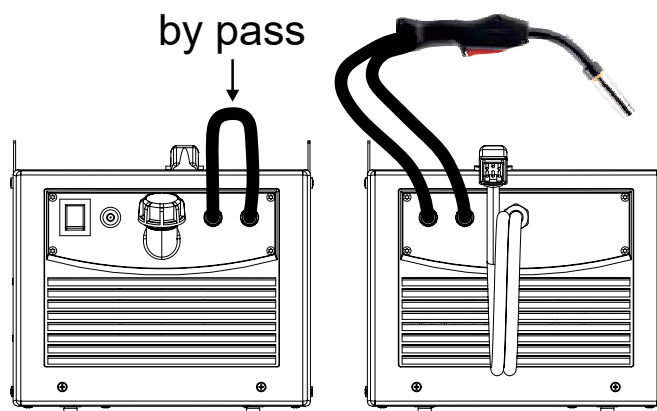

MIG / MAG configuration



3 TECHNICAL DATA

Directives applied	Waste electrical and electronic equipment (WEEE)
	Electromagnetic compatibility (EMC)
	Low voltage (LVD)
	Restriction of the use of certain hazardous substances (RoHS)
Construction standards	EN 60974-2; EN 60974-10 Class A
Conformity markings	 Equipment compliant with European directives in force
	 Suitable in an environment with increased hazard of electric shock
	 Compliant with WEEE directive
	 Equipment compliant with RoHS directive

3.1 CU-09/CU-09F

Supply voltage	1 x 400 V~ ± 15 % / 50-60 Hz
Dimensions (D x L x H)	720 x 290 x 235 mm
Weight	20.8 kg (25.2 kg with liquid)
Tank capacity	4.5 l
Protection rating	IP23S
Maximum input current (A)	1.0 A (50 Hz) - 1.1 A (60 Hz)
Cooling power	950 W (1l/min) - 2.8 kW (max. l/min)
Maximum pressure	0.32 MPa (50 Hz) - 0.43 MPa (60 Hz)

3.2 CU-09-HP

Supply voltage	1 x 400 V~ ± 15 % / 50-60 Hz
Dimensions (D x L x H)	720 x 290 x 235 mm
Weight	20.8 kg (25.2 kg with liquid)
Tank capacity	4.5 l
Protection rating	IP23S
Maximum input current (A)	1.35 A (50 Hz) - 1.53 A (60 Hz)
Cooling power	950 W (1l/min) - 2.8 kW (max. l/min)
Maximum pressure	0.41 MPa (50 Hz) - 0.51 MPa (60 Hz)

The technical characteristics of the antifreeze liquid supplied with this appliance are found below:

Base	Refrigerants polymers with low pour point
Appearance	Liquid
Color	Colorless
Odor	Odorless
Specific weight	1.030 g/cm ³
Viscosity	< 100 cP
pH	7 / 8
Refractive index	1.369 nD (20 °C)
Boiling point	102 °C
Specific heat	3.9 kJ/kg K
Thermal conductivity	0.45 W/m k (25 °C)
Electrical conductivity	2.3 mS/cm (20 °C)
Dissolved chloridea	< 2 ppm
Dissolved sulfides	< 2 ppm
Hardness	< 0.1 mol/m ³ (Ca ⁺⁺ , Mg ⁺⁺)
Biodegradability	Complete
Foaming power	No
Solubility	Soluble in water

4 SPARE PARTS

4.1 CU-09 / CU-09-HP

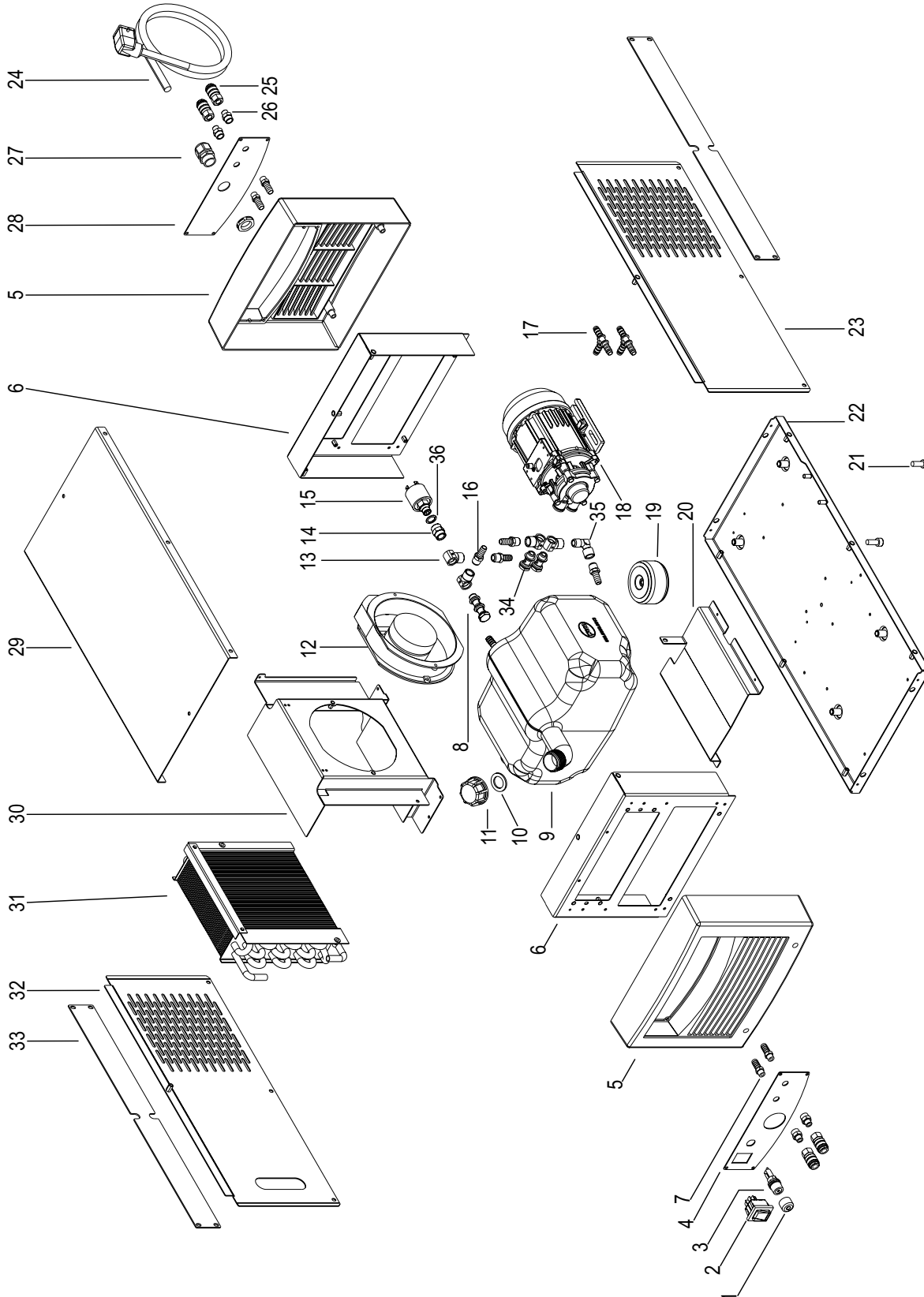

N°	CODE	DESCRIPTION
1	016.0011.0004	FUSE CARRIER CAP
2	040.0001.0003	SWITCH
3	040.0006.1880	FUSE HOLDER
4	011.0012.0103	FRONT PLATE
5	012.0006.0010	FRONT-REAR PLASTIC PANEL
6	011.0012.0101	FRONT/REAR PLATE
7	016.5001.3041	SLEEVE HOSE ADAPTER FOR RUBBER HOSE Ø= 10 mm F= 1/8 M
8	017.0003.0022	DOUBLE HOLLOW BOLT M= 1/4
9	003.0003.0013	TANK
10	003.0003.0016	GASKET
11	003.0003.0015	CAP
12	003.0002.0016	FAN
13	017.0003.0024	HYDRAULIC SWIVEL JOINT LF= 1/4
14	017.0003.0056	F= 1/4 - M= 1/4 NIPPLE CONNECTOR
15	017.0006.0007	PRESSURE SWITCH
16	016.5001.3042	SLEEVE HOSE ADAPTER FOR RUBBER HOSE d= 10 mm F= 1/4 M
17	010.0000.0094	"T" SLEEVE HOSE ADAPTER FOR RUBBER HOSE d= 8 mm
18	003.0004.0026	PUMP CU-09
18	003.0004.0041	PUMP CU-09-HP
19	041.0006.0008	AUXILIARY TRANSFORMER
20	011.0012.0106	TANK FIXING PLATE
21	016.0201.0624	FOOT
22	011.0012.0100	LOWER CASE
23	011.0000.1061	LEFT SIDE COVER
24	022.0002.0074	POWER SUPPLY CABLE
25	018.0002.0004	QUICK CLUTCH 1/8 GAS
26	017.0003.0055	F=1/8 - M=1/8 NIPPLE CONNECTOR
27	045.0000.0014	CABLE CLAMP
28	011.0012.0104	REAR PLATE
29	011.0012.0102	UPPER COVER
30	011.0012.0108	RADIATOR SUPPORT
31	003.0003.0014	RADIATOR
32	011.0000.1051	RIGHT SIDE COVER
33	011.0012.0107	CLAMPING PLATE
34	017.0003.0021	HOLLOW BOLT M= 1/4
35	017.0003.0027	90° F= 1/4 - M= 1/4 NIPPLE CONNECTOR
36	016.1001.1001	WASHER 1/4 GAS NYLON

4.2 CU-09F

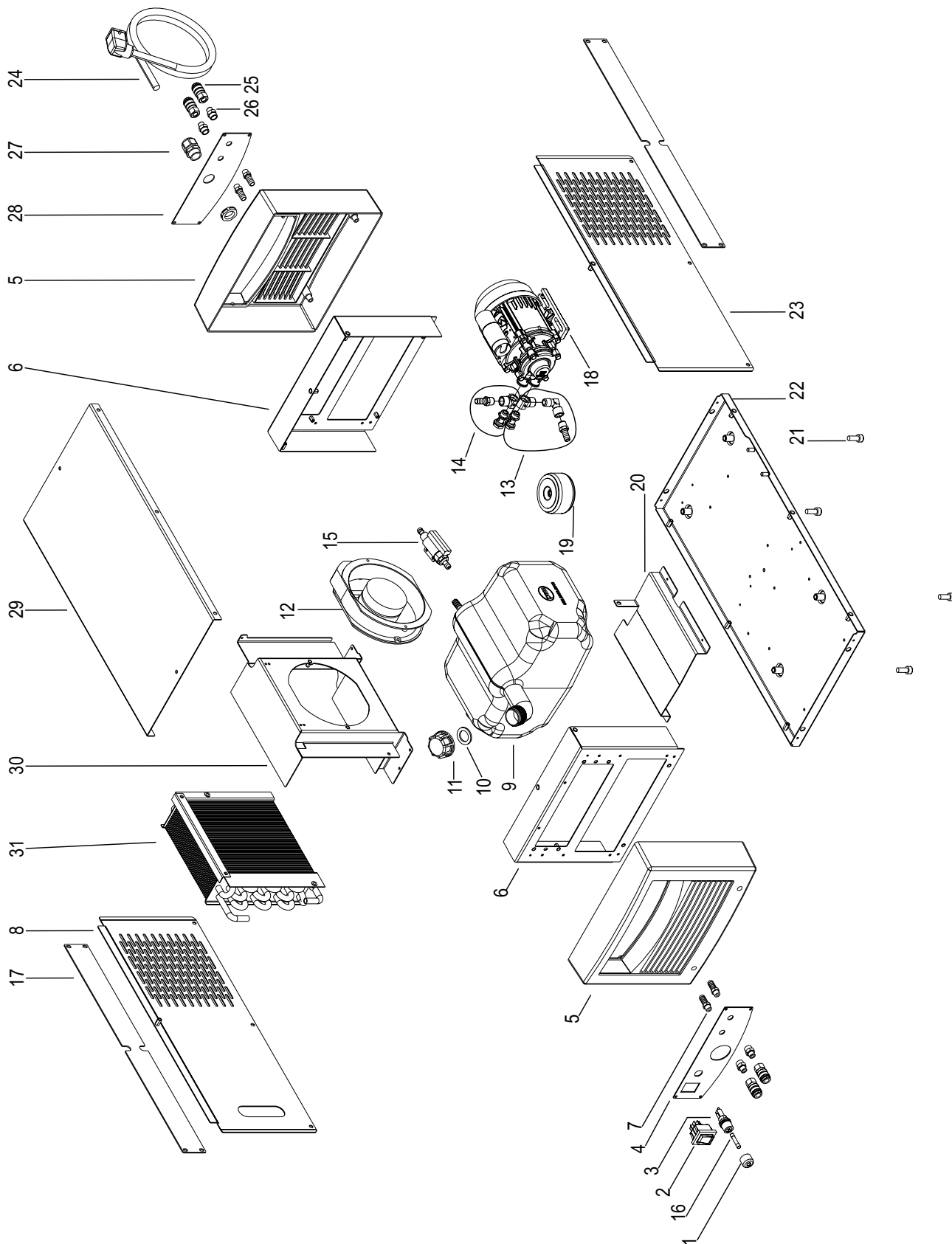

N°	CODE	DESCRIPTION
1	016.0011.0004	FUSE CARRIER CAP
2	040.0001.0003	SWITCH
3	040.0006.1880	FUSE HOLDER
4	011.0012.0103	FRONT PLATE
5	012.0006.0010	FRONT-REAR PLASTIC PANEL
6	011.0012.0101	FRONT/REAR PLATE
7	016.5001.3041	SLEEVE HOSE ADAPTER FOR RUBBER HOSE Ø= 10 mm F= 1/8 M
8	011.0000.1051	RIGHT SIDE COVER
9	003.0003.0013	TANK
10	003.0003.0016	GASKET
11	003.0003.0015	CAP
12	003.0002.0016	FAN
13	010.0000.0071	PUMP UPPER CONNECTION KIT (B)
14	010.0000.0070	PUMP UPPER CONNECTION KIT (A)
15	017.0006.0008	FLUXMETER
16	040.0007.1160	FUSE 1,6A 500V
17	011.0012.0107	CLAMPING PLATE
18	003.0004.0026	PUMP CU-09
19	041.0006.0008	AUXILIARY TRANSFORMER
20	011.0012.0106	TANK FIXING PLATE
21	016.0201.0624	FOOT
22	011.0012.0100	LOWER CASE
23	011.0000.1061	LEFT SIDE COVER
24	022.0002.0074	POWER SUPPLY CABLE
25	018.0002.0004	QUICK CLUTCH 1/8 GAS
26	017.0003.0055	F=1/8 - M=1/8 NIPPLE CONNECTOR
27	045.0000.0014	CABLE CLAMP
28	011.0012.0104	REAR PLATE
29	011.0012.0102	UPPER COVER
30	011.0012.0108	RADIATOR SUPPORT
31	003.0003.0014	RADIATOR

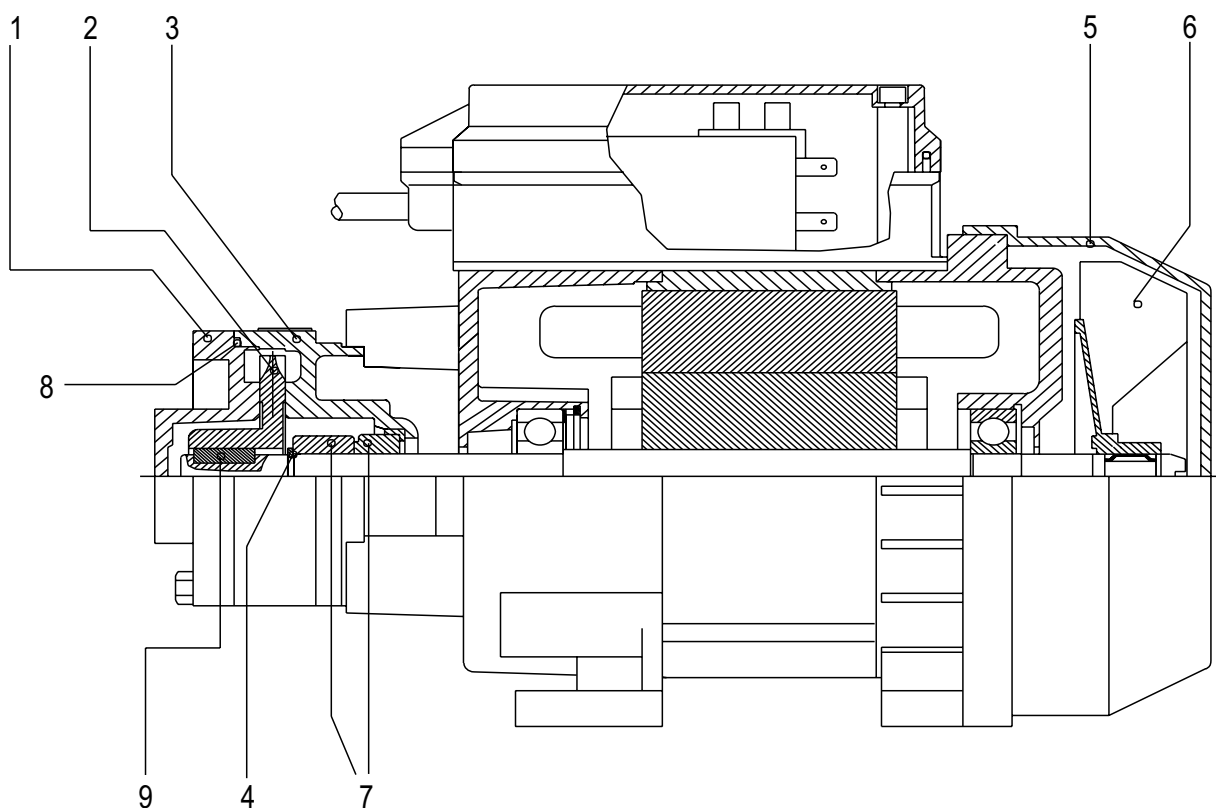

N°	CODE	DESCRIPTION
1	003.0004.0017	PUMP BODY ¼ GAS
2	003.0004.0018	IMPELLER
3	003.0004.0019	SEAL BODY
4	003.0004.0020	SEAL SEEGER
5	003.0004.0008	COVER FAN
6	003.0004.0007	FAN
7	003.0004.0021	MECHANICAL COMPLETE SEAL
8	003.0004.0023	BODY O-RING
9	003.0004.0022	SHAFT KEY

4.3 COUPLINGS KIT ALREADY ASSEMBLED

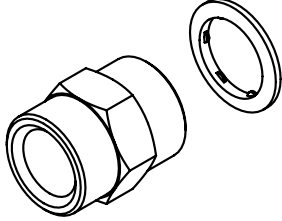
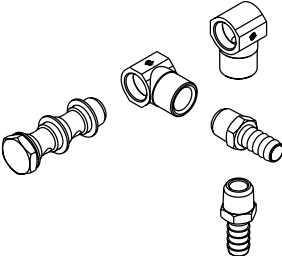
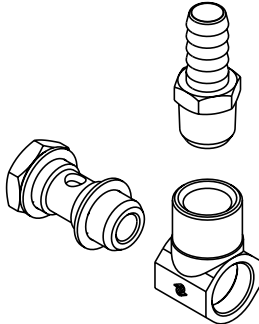
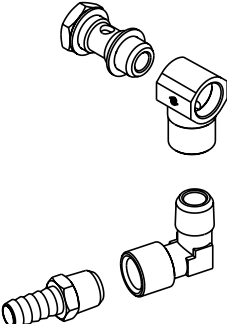
N°	CODE	DESCRIPTION
	010.0000.0067	PRESSURE SWITCH CONNECTOR KIT
	010.0000.0069	PRESSURE SWITCH PIPE DOUBLE CONNECTOR KIT
	010.0000.0070	PUMP UPPER CONNECTION KIT (A)
	010.0000.0071	PUMP LOWER CONNECTION KIT (B)

5 ELECTRICAL DIAGRAM

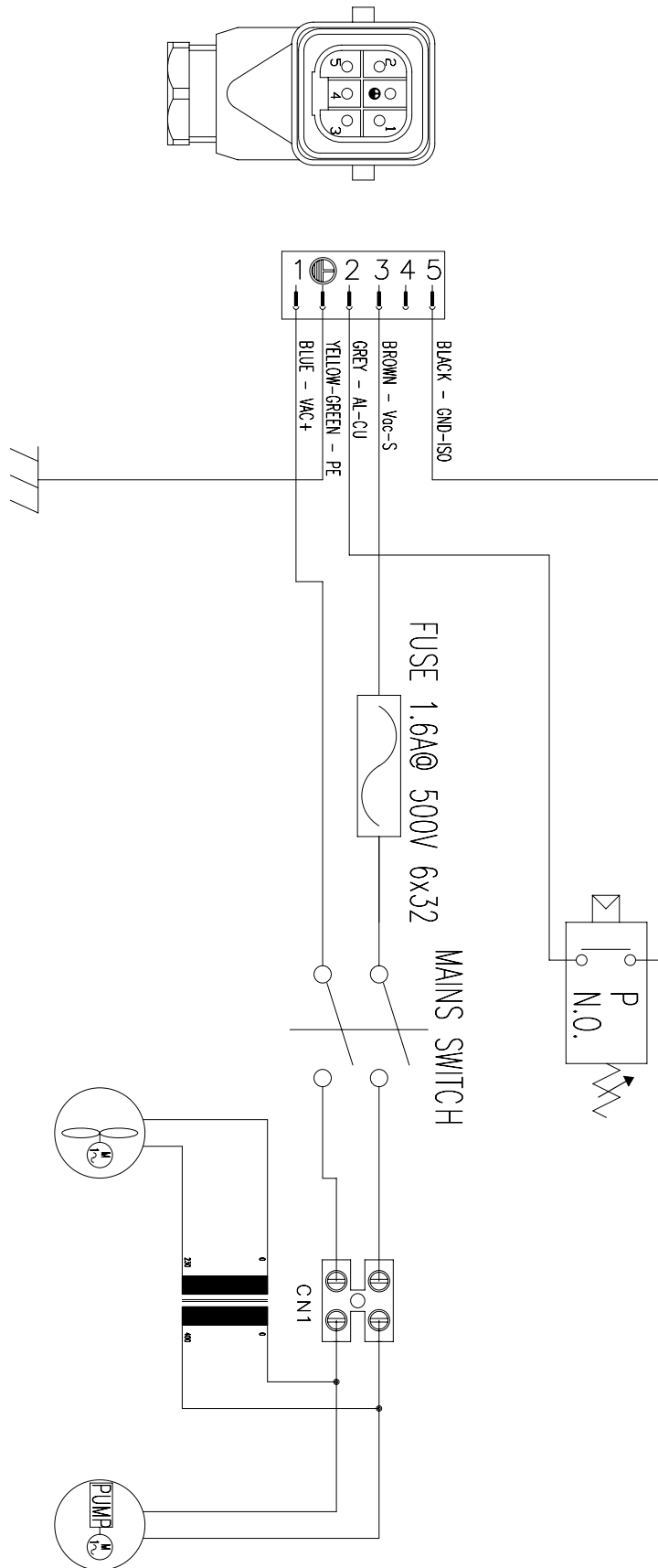

CU-09
CU-09-HP
CU-09F



Cod.006.0001.1660
24/03/2021 v2.8

ENGLISH



WELD THE WORLD

www.weco.it

