



WELD THE WORLD

Multi Power 204T

Instruction manual







INDEX

1	INTRODUCTION	4
1.1	PRESENTATION.....	5
2	INSTALLATION	6
2.1	CONNECTIONS TO THE MAINS POWER SUPPLY	6
2.2	FRONT PANEL.....	6
2.3	REAR PANEL.....	7
2.4	PREPARING FOR MMA WELDING.....	8
2.5	PREPARING FOR TIG WELDING	9
3	USER INTERFACE	10
4	UNIT POWER-UP	13
5	RESET (LOAD FACTORY SETTINGS)	14
6	SET-UP (INITIAL SET-UP OF THE WELDING POWER SOURCE)	15
6.1	TORCH LOADING	17
7	ALARM MANAGEMENT	18
8	DERATING	20
9	MMA WELDING	21
9.1	MMA WELDING - FIRST LEVEL MENU	21
9.2	MMA WELDING - SECOND LEVEL MENU	23
9.3	MMA WELDING - SPECIAL FUNCTIONS	25
10	DC TIG WELDING	26
10.1	DC TIG WELDING - FIRST LEVEL MENU	26
10.2	TIG DC WELDING - SECOND LEVEL MENU	31
10.3	TIG DC WELDING - SPECIAL FUNCTIONS MENU	34
11	TORCH TRIGGER PROCEDURE	38
11.1	2 STROKE SPOT - Q-SPOT FUNCTION	44
12	JOBS MANAGEMENT	49
12.1	SAVING A JOB	49
12.2	DELETING A JOB	50
12.3	LOADING A JOB	51
12.4	SELECTING JOBS USING THE TORCH BUTTONS	51
13	TECHNICAL DATA	52
13.1	MULTI POWER 204T	52
14	WIRING DIAGRAM	54
14.1	TORCH CONNECTOR (front panel).....	55
14.2	REMOTE CONTROL CONNECTOR (back panel).....	55
15	SPARES	56
15.1	MULTI POWER 204T	56
15.2	TORCH CONNECTORS COMPLETE KIT.....	58

1 INTRODUCTION

 	IMPORTANT!
<p><i>This handbook must be consigned to the user prior to installation and commissioning of the unit. Read the "General prescriptions for use" handbook supplied separately from this handbook before installing and commissioning the unit.</i></p> <p><i>The meaning of the symbols in this manual and the associated precautionary information are given in the "General prescriptions for use".</i></p> <p><i>If the "General prescriptions for use" are not present, it is mandatory to request a replacement copy from the manufacturer or from your dealer.</i></p> <p><i>Retain these documents for future consultation.</i></p>	

LEGEND

	DANGER!
<i>This pictogram warns of danger of death or serious injury.</i>	

	WARNING!
<i>This pictogram warns of a risk of injury or damage to property.</i>	

	CAUTION!
<i>This pictogram warns of a potentially hazardous situation.</i>	

	INFORMATION!
<i>This pictogram gives important information concerning the execution of the relevant operations.</i>	

- ➡ This symbol identifies an action that occurs automatically as a result of a previous action.
- ① This symbol identifies additional information or a reference to a different section of the manual containing the associated information.
- § This symbol identifies a reference to a chapter of the manual.
- *1 The symbol refers to the associated numbered note.

NOTES

The figures in this manual are purely guideline and the images may contain differences with respect to the actual equipment to which they refer.

1.1 PRESENTATION

Multi Power 204T is an inverter DC TIG/MMA portable welding power source.

The sturdiness of the components of this unit makes it a reliable working companion for workshop and outdoor applications.

The available DC TIG functions and digital control make this unit ideal for maintenance, building construction, and light metalwork.

In MMA welding the Hot Start and Arc Force functions are adjustable and they allow improved arc striking, a flatter bead and more uniform weld.

The Anti Sticking function makes it possible to detach the electrode rapidly from the workpiece in the event of accidental sticking.

Up to 4,00mm diameter electrode welding is possible in MMA.

The power source is designed to guarantee safety and flexibility through the following features:

OVERCUT: in case of over-voltage in the supply line, the supply to the power source is cut off.

The overcut protection protects electronic parts of the machine against damage caused by voltage surges.

CURRENT AUTO-CALIBRATION: the power source works at a supply voltage ranging between 115V~±15%/50-60Hz and 230V~±15%/50-60Hz.

The maximum value of the adjustable welding current is automatically limited based on the supply voltage measured when the power source is switched on.

DERATING: Derating limits current during welding when supply voltage drops below the limit value of 190Vac.













This limits current input so as not to overload the inverter and keeps the welding arc stable.

FANS: Fan speed varies based on power source internal temperature measured by thermal sensors.

This function brings the following improvements:

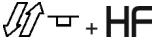
- reduction of noise.
- reduction of dust extracted (cleaner equipment, less maintenance).

The welding modes and procedures available are those indicated in the table.

MODE		PROCEDURE	
	MMA		
	TIG CONTINUOUS		2 STROKE LIFT-ARC (2T)
			2 STROKE + HF (2T HF)
			4 STROKE LIFT-ARC (4T)
	TIG PULSED		4 STROKE + HF (4T HF)
			4 STROKE BI-LEVEL (4T B-LEVEL)
			4 STROKE BI-LEVEL + HF (4T B-LEVEL HF)
	SYNERGIC TIG		2T SPOT
			2T SPOT + HF

Accessories that can be connected to the unit:

- manual remote control for remote adjustment of the welding current.
- foot-pedal remote control for TIG torch arc striking and remote adjustment of welding current.
- UP/DOWN torch or torch with potentiometer.
- liquid cooler for TIG torches.

2 INSTALLATION



DANGER! **Lifting and positioning**

Read the warnings highlighted by the following symbols in the “General prescriptions for use”.

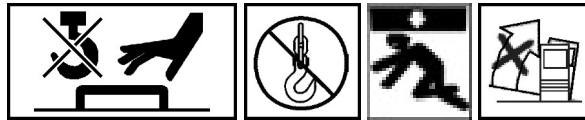

2.1 CONNECTIONS TO THE MAINS POWER SUPPLY

The characteristics of the mains power supply to which the equipment shall be connected are given in the chapter entitled “12 TECHNICAL DATA” on page 48.

The machine can be connected to motor-generators provided their voltage is stabilised.
Connect/disconnect the various devices with the machine switched off.

2.2 FRONT PANEL

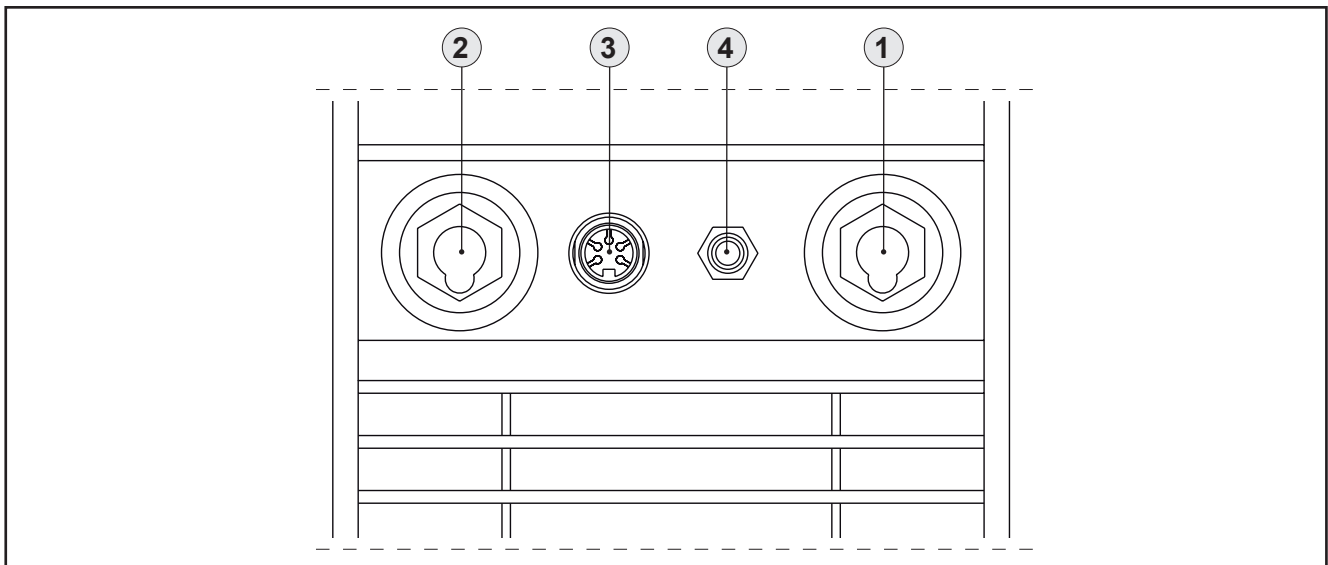

- Negative pole welding socket.[Item 1].
- Positive pole welding socket.[Item 2].
- Connector for logic signals of TIG torch.[Item 3].
- Connector for gas feed hose: Torch power source [Item 4].

2.3 REAR PANEL

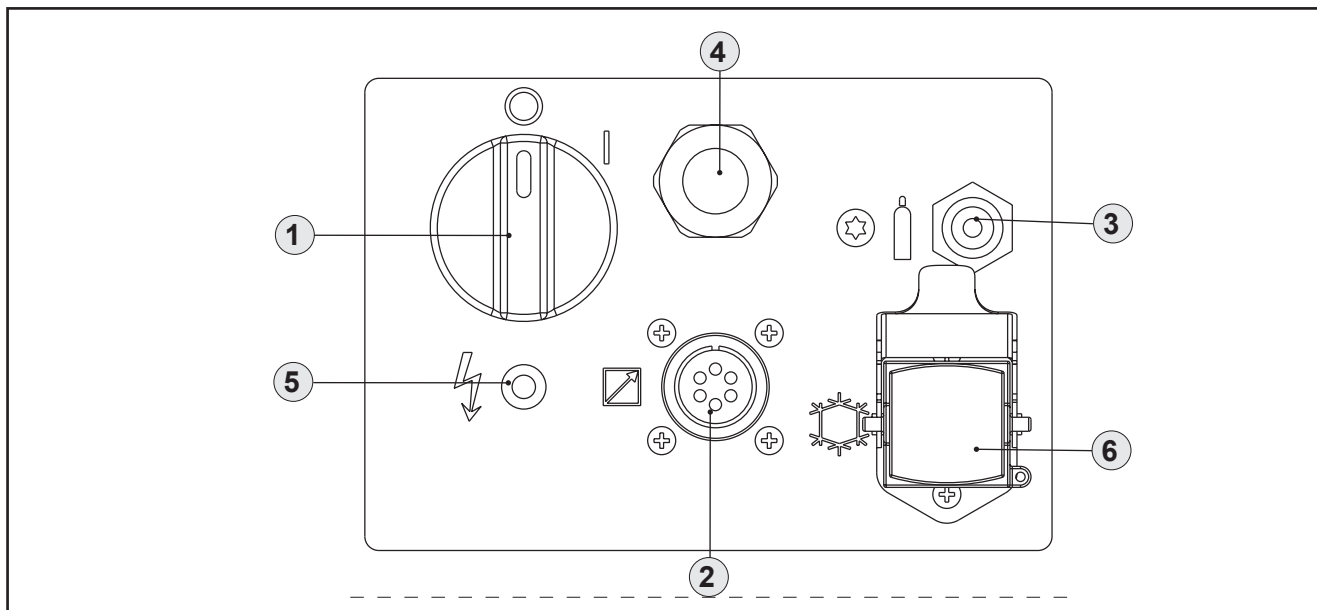

- Welding power source ON/OFF switch [Item 1].
- Remote control connector [Item 2].
- Connector for gas feed hose [Item 3]
 - cylinder-generator
- Power cable. [Item 4].
 - Total length (including internal part): 2.5 m;
 - Number and cross section of wires: 3 x 2.5 mm²
 - Type of plug supplied: Schuko
- Warning LED for overcut protection triggering [Item 5].
- Pre-arrangement for the supply socket of the cooling unit (purchasing and installing the relative kit) [Item 6].

2.4 PREPARING FOR MMA WELDING

1. Set the welding power source ON/OFF switch to “O” (unit off).
2. Plug the power cable plug into a mains socket.
3. Choose the electrode based on the type of material and thickness of the workpiece to be welded.
4. Insert the electrode in the electrode holder.
5. Connect the electrode holder clamp plug to the following welding socket: Positive pole welding socket.
6. Connect the earth clamp plug to the following welding socket: Negative pole welding socket.
7. Connect the earth clamp to the workpiece being processed.



DANGER!

Electric shock hazard!

Read the warnings highlighted by the following symbols in the “General prescriptions for use”.



8. Set the welding power source ON/OFF switch to “I” (unit on).
 9. Select the following welding mode on the user interface: MMA
 10. Set the required welding parameter values on the user interface.
- ➡ When the remote control [RC] is connected and enabled, the welding current can be adjusted.
The system is ready to start welding.

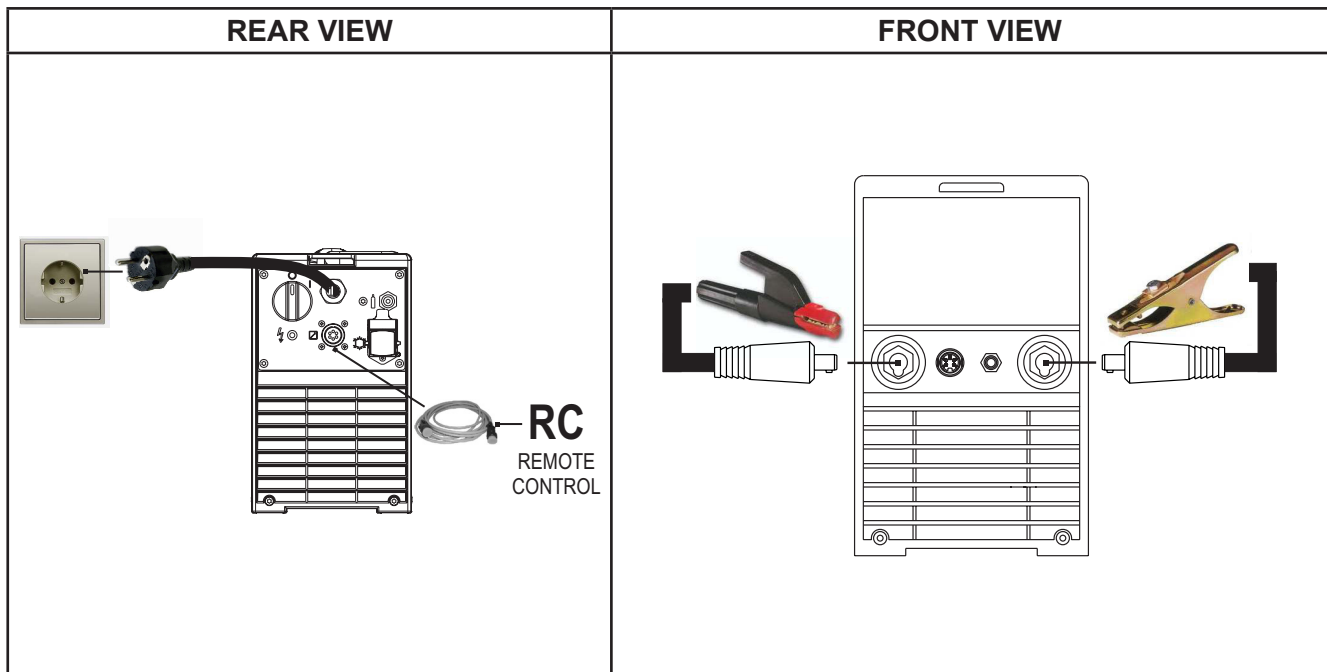

2.5 PREPARING FOR TIG WELDING

1. Set the welding power source ON/OFF switch to "O" (unit de-energized).
2. Plug the power cable plug into a mains socket outlet.
3. Connect the gas hose from the welding gas cylinder to the rear gas connection.
4. Open the cylinder gas valve.
5. Connect the gas hose of the welding torch to the front gas connection.
6. Connect the electrode holder clamp plug to the following welding socket: Negative pole welding socket.
7. Choose the electrode based on the type of material and thickness of the workpiece to be welded.
8. Insert the electrode in the TIG torch.
9. Connect the earth clamp plug to the following welding socket: Positive pole welding socket.
10. Connect the earth clamp to the workpiece being processed.
11. Set the welding power source ON/OFF switch to "I" (unit powered).
12. Select the following welding mode on the user interface: DC TIG
13. Press the torch trigger with the torch well clear of any metal parts. This serves to open the gas solenoid valve without striking the welding arc.
14. Use the flow control valve to adjust the flow of gas as required while the gas is flowing out.
15. Set the required welding parameter values on the user interface.

- ⓘ When the remote control pedal is connected and the relative locking screw is tightened the welding current will vary in relation to the pressure exerted on the pedal. The system is ready to start welding.

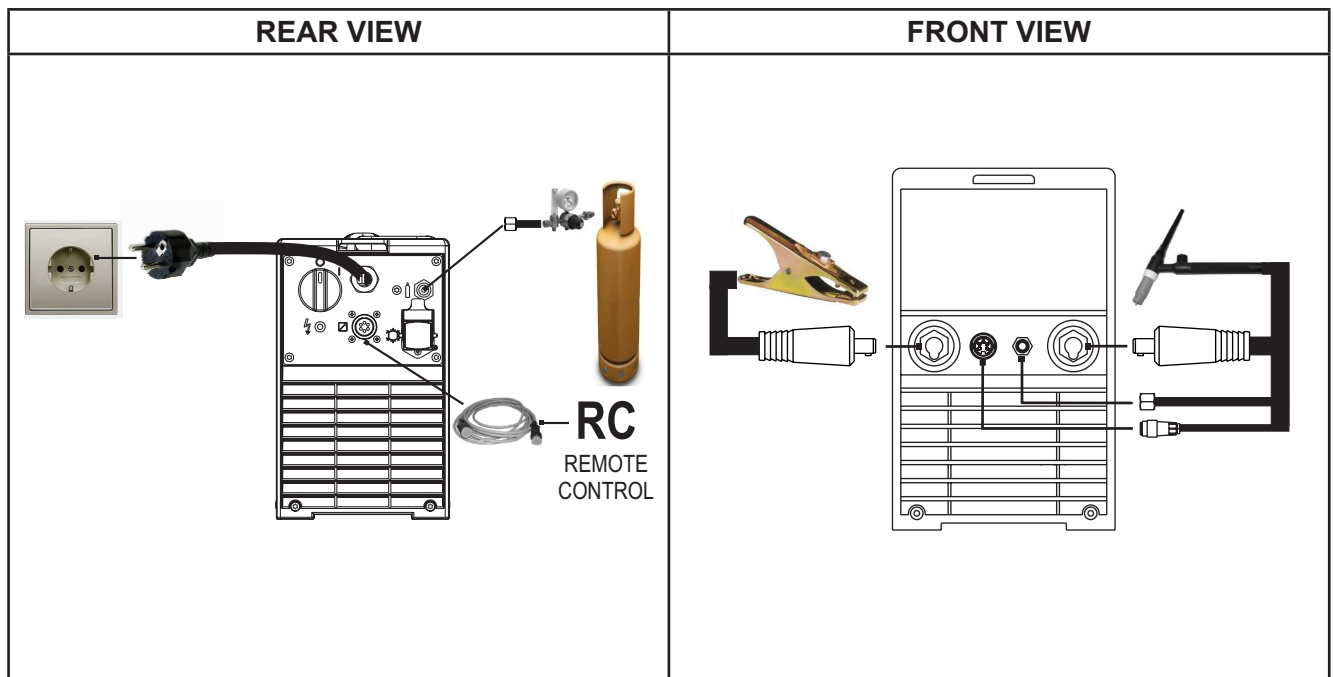





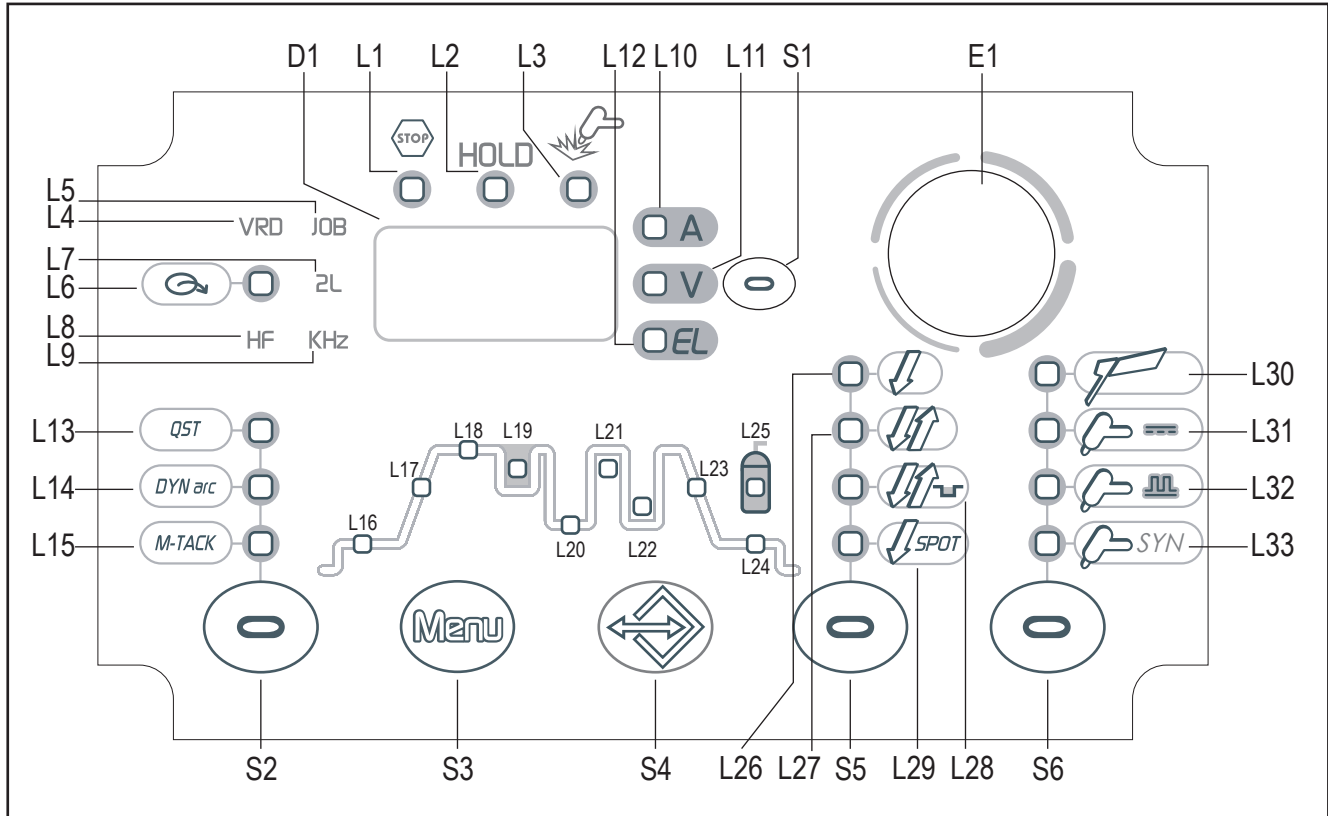













3 USER INTERFACE









MULTI POWER 204T



CODE	SYMBOL	DESCRIPTION
L1		This LED illuminates to show an anomaly in the operating conditions.
L2	HOLD	Illuminates to show the last voltage and current values measured during welding. The value appears on the display D1: The "HOLD" function is cleared when a new weld is started or when any setting is changed.
L3		This LED illuminates to confirm the presence of power on the output sockets.
L4	VRD	Illumination shows that the following function has been activated: VRD (reduced output voltage). The no-load voltage between the welding sockets is switched from U0 to Ur (see technical data).
L5	JOB	Illuminates to show that a previously saved JOB has been loaded.
L6		This LED indicates that the current reference is set up by the remote control.
L7	2L	When this LED illuminates the 2nd level Menu parameter is shown.
L8	HF	Illumination shows that the following function has been activated: HIGH FREQUENCY ARC STRIKE (HF)
L9	KHz	Illuminates to show a value in the following unit of measurement: KILOHERTZ
L10	A	Illuminates to show a value in the following unit of measurement: AMPERES
L11	V	Illuminates to show a value in the following unit of measurement: VOLTS
L12	EL	Illumination shows that the following parameter can be displayed: ELECTRODE TYPE

L13	QST	Illumination shows that the following parameter can be set: Q-START
L14	DYN arc	Illumination shows that the following parameter can be set: DYNAMIC ARC
L15	M-TACK	Illumination shows that the following parameter can be displayed: MULTI TACK
L16		Illumination shows that the following parameter can be set: STARTING CURRENT (%/A)
L17		Illumination shows that the following parameter can be set: SLOPE UP (s)
L18		Illumination shows that the following parameter can be set: WELDING CURRENT (A)
L19		Illumination shows that the following parameter can be set: SECOND CURRENT B-LEVEL (%)
L20		Illumination shows that the following parameter can be set: BASE CURRENT (A)
L21		Illumination shows that the following parameter can be set: PEAK TIME (s)
L22		illumination shows that the following parameter can be set: BASE TIME(s)
L21 + L22		illumination shows that the following parameter can be set: PULSED CURRENT FREQUENCY (Hz/kHz)
L23		illumination shows that the following parameter can be set: SLOPE DOWN (s)
L24		illumination shows that the following parameter can be set: STARTING CURRENT (%/A)
L25		illumination shows that the following parameter can be set: POST-GAS (s)
L26		Illumination shows that the following function has been activated: 2 stroke procedure.
L27		Illumination shows that the following function has been activated: 4 stroke procedure.
L28		Illumination shows that the following function has been activated: 4 stroke Bi-level procedure
L29		Illumination shows that the following function has been activated: 2 stroke spot procedure (SPOT).
L30		This LED illuminates to show that the following welding mode is selected: MMA
L31		This LED illuminates to show that the following welding mode is selected: TIG DC CONTINUOUS
L32		This LED illuminates to show that the following welding mode is selected: PULSED DC TIG
L33		This LED illuminates to show that the following welding mode is selected: SYNERGIC PULSED TIG When this is on, it means that the synergic mode is active and that the operator can set just the welding current while the other parameters are automatically regulated by the machine. The synergy is optimised by angle welding.

ENGLISH

D1		<p>Data setting: The display shows the acronym of the parameter to be set. Welding: The display shows the effective amperes value during welding. HOLD function: The display shows the average current value measured over the entire welding period (excluding the starting and ending slopes).</p>
E1		<p>Data setting: The encoder sets the value of the selected parameter. Welding: The encoder sets the value of the following parameter: WELDING CURRENT</p>
S1		<p>Parameters/functions setting: This button selects the parameter to be shown on the following display: D1 Possible choices: (A) Preset welding current (V) No-load voltage (EL) Preset type of electrode</p>
		<p>Welding: This button selects the parameter to be shown on the following display: D1 Possible choices: (A) Effective welding current (V) Effective welding voltage</p>
		<p>HOLD function: This button selects the parameter to be shown on the following display: D1 Possible choices: (A) Average welding current (V) Average welding voltage</p>
S2		<p>TIG Mode: Press the button to select the parameter to be set. Possible selections: Q-START, DYNAMIC ARC, MULTI TACK</p>
		<p>MMA mode: DYNAMIC ARC</p>
S3		<p>Press and release: the button selects the first level menu parameters. Hold down for 3 seconds: the button opens the second level menu. When in the menu, press and release the button to select the parameters. Keep the button pressed while powering on the power source: the button opens the SETUP menu.</p>
S4		<p>Press and release: the button opens the JOBS upload menu. Hold down for 3 seconds: the button opens the JOBS save and delete menu.</p>
S5		<p>TIG DC / TIG AC mode: This button selects the torch trigger procedure. MMA mode: Press the button to show the selected electrode type for MMA welding.</p>
S6		<p>This button selects the welding mode.</p>

4 UNIT POWER-UP

Set the welding power source ON/OFF switch to “I” to switch on the unit.

FX.X The message appears on the following display: **D1**.

x.x= software version

First power-up or power-ups following a RESET procedure

The welding power source sets up for welding with the factory preset values.

Subsequent power-ups

The welding power source sets up for welding in the latest stable welding configuration that was active at the time of power-off.

The power source works at a supply voltage ranging between 115V~±15%/50-60Hz and 230V~±15%/50-60Hz.

The maximum value of the adjustable welding current is automatically limited based on the supply voltage measured when the power source is switched on.

SUPPLY VOLTAGE	CURRENT RANGE THAT CAN BE SET (MMA)	CURRENT RANGE THAT CAN BE SET (TIG)
115 V~ ±15 % / 50 - 60 Hz	10 A – 115 A	5 A - 115 A
230 V~ ±15 % / 50 - 60 Hz	10 A – 180 A	5 A - 200 A

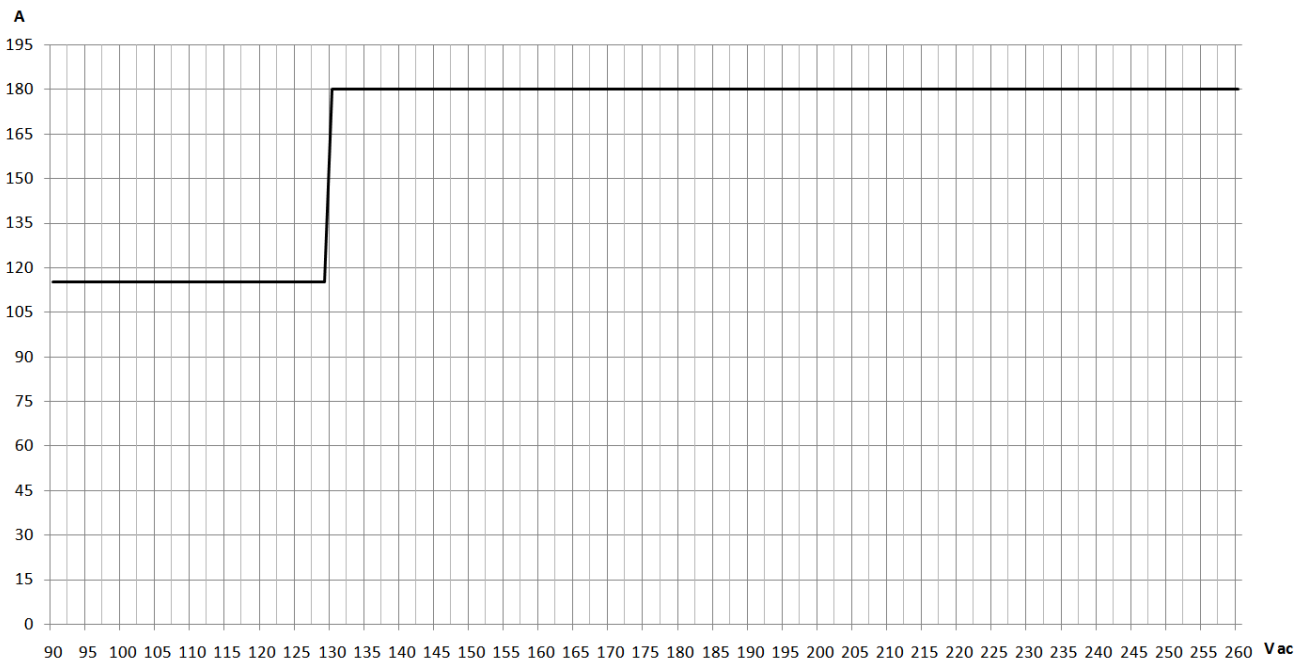

5 RESET (LOAD FACTORY SETTINGS)

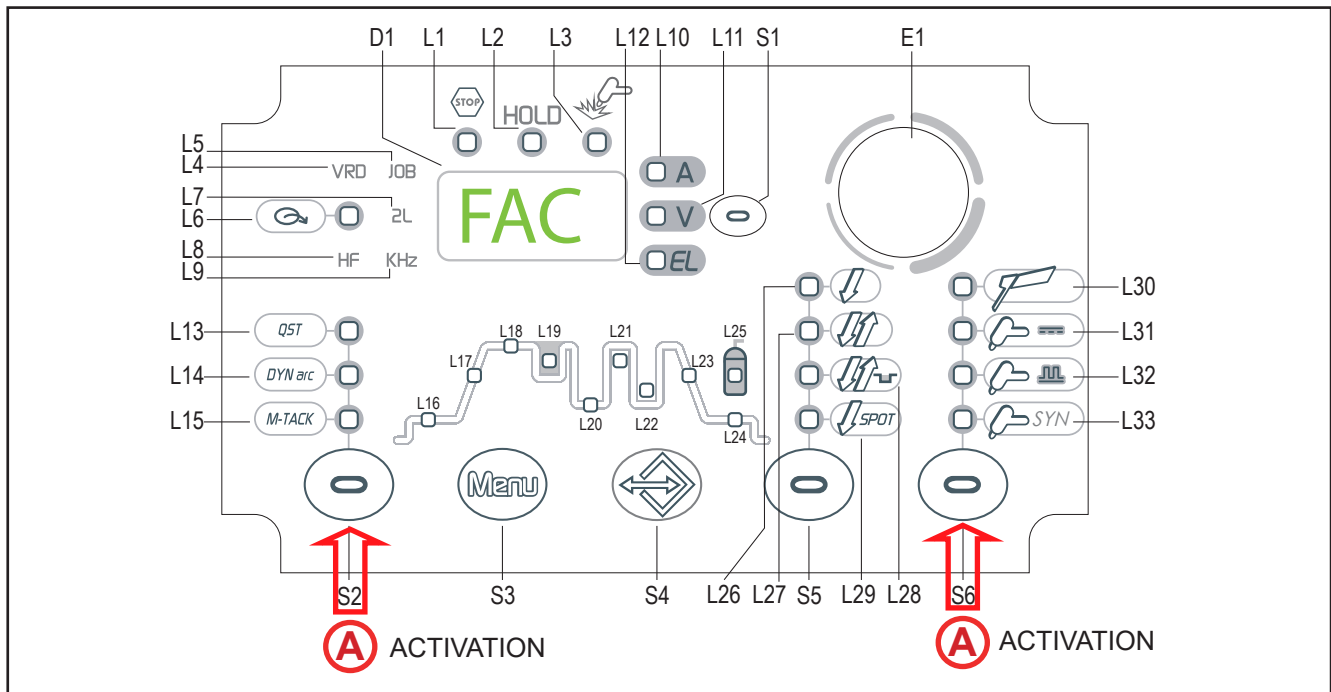

The reset procedure involves complete restoration of the default values, parameters and memory settings set in the factory.

All memory locations will be reset and hence all your personal welding settings will be lost!

The reset procedure is useful in the following cases:

- Too many changes made to the welding parameters so user finds it difficult to restore defaults.
- Unidentified software problems that prevent the welding power source from functioning correctly.

	<ul style="list-style-type: none"> ○ Set the welding power source ON/OFF switch to “O” to switch the unit off. ○ Keeping both the S2 and S6 buttons pressed, set the generator power source switch to “I” to turn on the equipment [SIMULTANEOUS ACTIONS] ○ Press both buttons S2 and S6 <ul style="list-style-type: none"> ● FAC: The message will appear on display D1 <ul style="list-style-type: none"> - Wait for the memory clear procedure to terminate. This action will automatically close the menu.
--	--

6 SET-UP (INITIAL SET-UP OF THE WELDING POWER SOURCE)

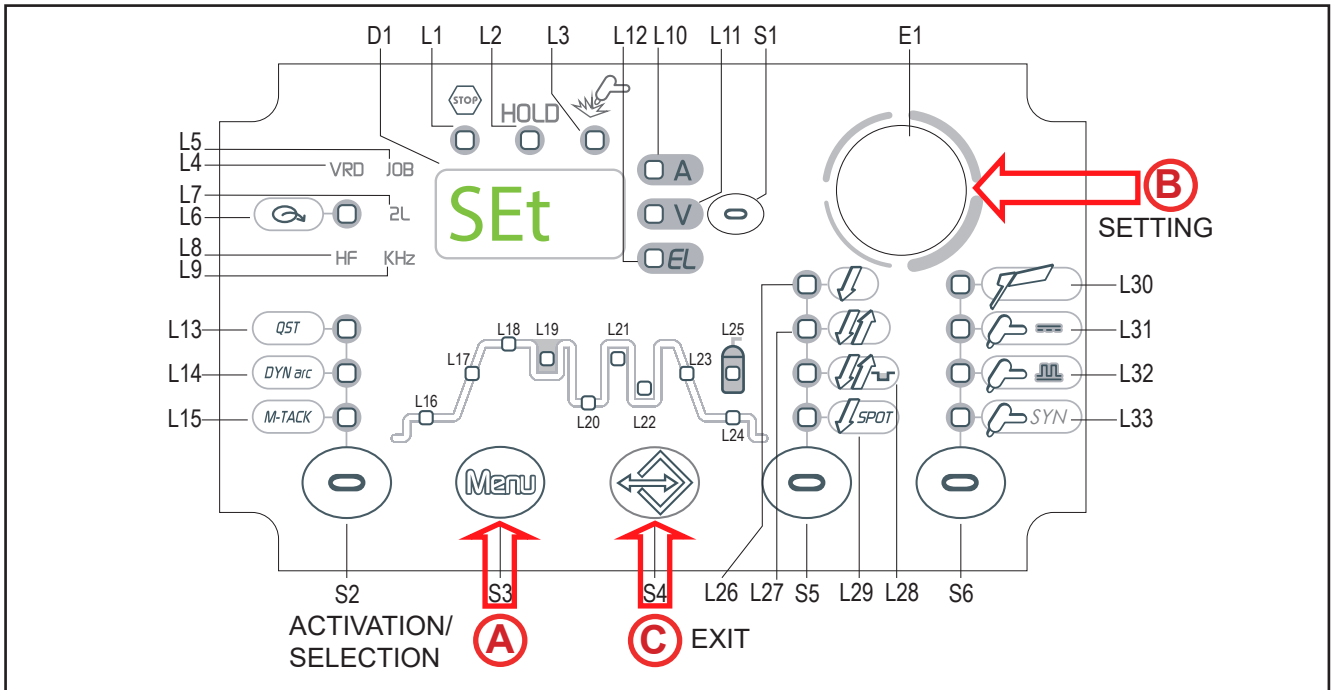

- Set the welding power source ON/OFF switch to “O” to switch the unit off.
 - Holding the **S3** (Menu) button down, turn the power source switch to “I” to start the equipment. [**⚠ SIMULTANEOUS ACTIONS**]
 - **Set** : The message will appear for a few seconds on display **D1**.
 - Press the **S3** (Menu) button to confirm.
 - The value relative to the selected setting will appear on display **D1**.
- (A)**
- Using the **encoder E1** (Encoder), edit the value of the selected setting.
- (B)**
- **Exit with confirmation**
 - Press any button (except **S3**) for example **S4** (Exit) to save the setting and quit the menu.
- (C)**

Tab. 1 - Setup settings

ACRONYM / LED	SETTING	MIN	DEFAULT	MAX
Coo	COOLER ACTIVATION	oFF	AUt	on
St.C.	STARTING CURRENT	%	%	A
F.Cu.	FINAL CURRENT	%	%	A
HF.C.	HF CURRENT	20 A	SYn	150 A
PUL.	TYPE OF PULSED CURRENT	SLo.	FA.	FA.
P.A.	PILOT ARC	oFF	on	on
StS	SPECIAL TORCH STROKE	oFF	oFF	2
rHF	RESTART HF	oFF	on	on
GE n	POWERSUPPLYFROMMOTORGENERATOR	oFF	oFF	On

ENGLISH

- Coo [COOLER ACTIVATION GROUP]

- ON= The cooler is always running when the power source is switched on. This mode is preferable for heavy duty and automatic welding procedures.
- OFF= The cooler is always disabled because an air-cooled torch is in use.
- AUT= When the unit is switched on the cooler is switched on for 15s. During welding procedures the cooler runs constantly. When welding is terminated the cooler continues to run for 90s + a number of seconds equivalent to the average current value shown using the HOLD function.

- St.C. [STARTING CURRENT]

- The value of this parameter can be set as a percentage of the welding current or as an absolute value expressed in Amperes.

F.Cu. [FINAL CURRENT]

- The value of this parameter can be set as a percentage of the welding current or as an absolute value expressed in Amperes.

- HF.C. [HF CURRENT]

- This parameter establishes the current value during HF discharge. The value of this parameter can be set as an absolute value or in SYN.
- With SYN setting the HF current value is calculated automatically on the basis of the preset welding current value.

Consequences of a higher value:

- Arc striking is facilitated, even on very dirty workpieces.
- Risk of piercing excessively thin gauge workpieces.

- PUL. [TYPE OF PULSED CURRENT]

- SLo. = This setting enables slow pulsed mode. The peak time and Base time are set.
- FA.= This setting enables fast pulsed mode. The frequency and duty-cycle are set.

- P.A. [PILOT ARC]

- The function enables the output of a low current between the 1st and 2nd times of the torch trigger to shield the mask in advance and avoid the risk of blinding flashback caused by the welding current.

-StS [SPECIAL TORCH STROKE]

- The parameter changes the torch trigger operating mode.
 - oFF: indicates standard operation.
 - 1: specifies the 4T B-level management variant. Allows the transition to the secondary welding current by pressing and holding down the UP or DOWN button; when the button is released, the primary current is restored. With variant oFF selected, the UP/DOWN buttons are disabled for all procedures.
 - 2: specifies the down slope management variant. By releasing the torch trigger during the third stroke (3S) the down slope is stopped and the final current is immediately delivered without having to go through the entire slope time.

-rHF [RESTART HF]

- This parameter changes the HF arc striking operation in the HF 4 stroke torch button mode. When set to "oFF", the automatic HF arc striking discharge is disabled when the long arc welding mode is exited; to restart the welding operation, the torch trigger must be pressed again. When set to "on" and the long arc welding mode is exited, the HF discharge is automatically started as soon as the torch electrode approaches the workpiece. Disabling the automatic striking is useful to prevent the accidental arc striking when the torch touches a part connected to the equipment earth (such as the welding table) after exiting the long arc welding mode.
-

- GEN (POWER SUPPLY FROM MOTORGGENERATOR)

- Set this function to “On” when the machine is powered by the motogenerator.

6.1 TORCH LOADING**WARNING!**

Make sure the torch in use is correctly sized in relation to the welding current required and for the available and selected cooling type. This prevents the risk of burns to which the operator is potentially exposed, potential faults, and irreversible damage to the torch and the system.

If a torch is installed or replaced while the unit is running, the circuit of the newly installed torch must be filled with coolant to avoid the risk of damage to the torch in the case of high voltage arc strikes without any liquid in the circuit.

Power-up with operation of the cooler set to “ON” or “AUT” mode

- A check is performed automatically of the presence of liquid in the cooling circuit and the cooler is switched on for 15 seconds.
- If the coolant circuit is full, the power source sets up in the most recent stable welding configuration.
- If the coolant circuit is not full, all functions are inhibited and there will be no output power present.

AL. Coo. : The message appears on the following displays: **D1**.



Press any button to repeat the checking procedure for an additional 15seconds.
If the problem persists, rectify the cause of the alarm.

Power-up with operation of the cooler set to “OFF”

Operation of the cooler and the cooler alarm are disabled.
Welding is performed without liquid cooling of the torch.

Torch change-over with operation of the cooler set to “ON”

Press and release the torch trigger.

This serves to start the cooler for 15 seconds to fill the torch cooling circuit.

7 ALARM MANAGEMENT



This LED illuminates if an incorrect operating condition occurs.

➡ An alarm message will appear on display **D1**.

Tab. 2 - Alarm messages

MESSAGE	MEANING	EVENT	CHECKS
AI. H.	<p>Overheating alarm Indicates tripping of the welding power source thermal protection. Leave the unit running so that the overheated components cool as rapidly as possible. When the unit has cooled, the welding power source will reset automatically.</p>	<p>All functions disabled. <u>Exceptions:</u> • Cooling fan.</p>	<ul style="list-style-type: none"> • Make sure that the power required by the welding process is lower than the maximum rated power output. • Check that the operating conditions are in compliance with the welding power source data plate specifications. • Check for the presence of adequate air circulation around the welding power source.
E. 04	<p>Alarm, no-load voltage failure</p>	<p>All functions disabled. <u>Exceptions:</u> • Cooling fan</p>	<ul style="list-style-type: none"> • Check to ensure the welding torch is not resting on the work-piece connected to ground. • Check that when the power source is switched on there is no short circuit between the sockets (voltage must be greater than/equivalent to U_r). <p>If the problem persists:</p> <ul style="list-style-type: none"> • qualified technical personnel are required for repair/maintenance jobs.
AI.P.	<p>Power board alarm It means that the power board is malfunctioning</p>	<p>All functions disabled. <u>Exceptions:</u> • Cooling fan.</p>	<ul style="list-style-type: none"> • Check that the operating conditions are in compliance with the welding power source data plate specifications. • If the problem persists: qualified technical personnel are required for maintenance jobs

MESSAGE	MEANING	EVENT	CHECKS
AI.C.	<p>Cooler alarm Indicates insufficient pressure in the torch liquid cooling circuit.</p>	<p>All functions disabled.</p> <p><u>Exceptions:</u></p> <ul style="list-style-type: none"> Cooling fan. <p>The alarm message persists on the display until the first operation is performed on the user interface.</p> <ul style="list-style-type: none"> Cooler "ON": the alarm is signalled as long as the unit alarm is active and the cooler presence signal persists. Cooler "OFF": the alarm is never signalled, irrespective of the circumstances. Cooler "AUT": the alarm is signalled at the times in which the unit is running; the alarm signal occurs as long as the unit presence signal persists. 	<ul style="list-style-type: none"> Check that the connection to the cooler is correct. Check that the O/I switch is set to I and that it illuminates when the pump is running. Check that the cooler is filled with coolant. Check that the cooling circuit is liquid tight, notably the torch hoses and the internal connections of the cooler.

8 DERATING

Derating is a machine function that cannot be selected by the user.

Derating limits the maximum welding current if the supply voltage drops below 190Vac.

For example, if the power source is set to weld with a current of 175A, that current will be the power source output until the supply voltage will range between 184Vac and 230Vac.

If voltage drops to 165Vac, the power source automatic output current will be 160A.

The following diagram displays the maximum output current, based on the voltage supplied to the power source.

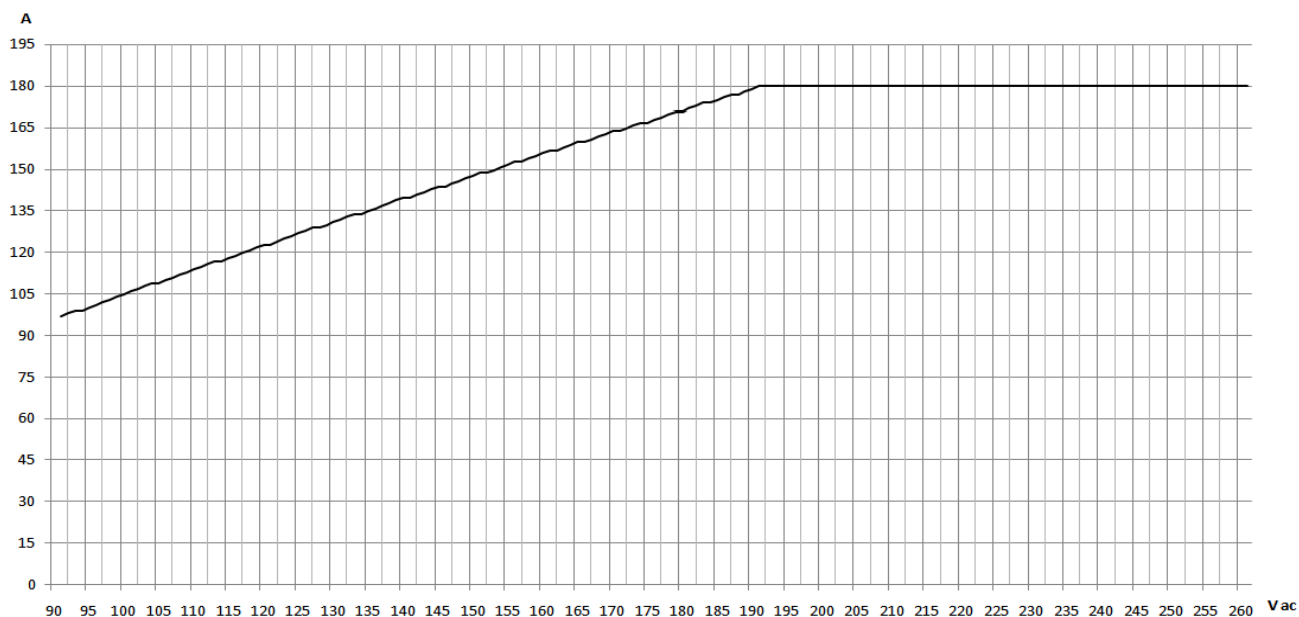

9 MMA WELDING

9.1 MMA WELDING - FIRST LEVEL MENU

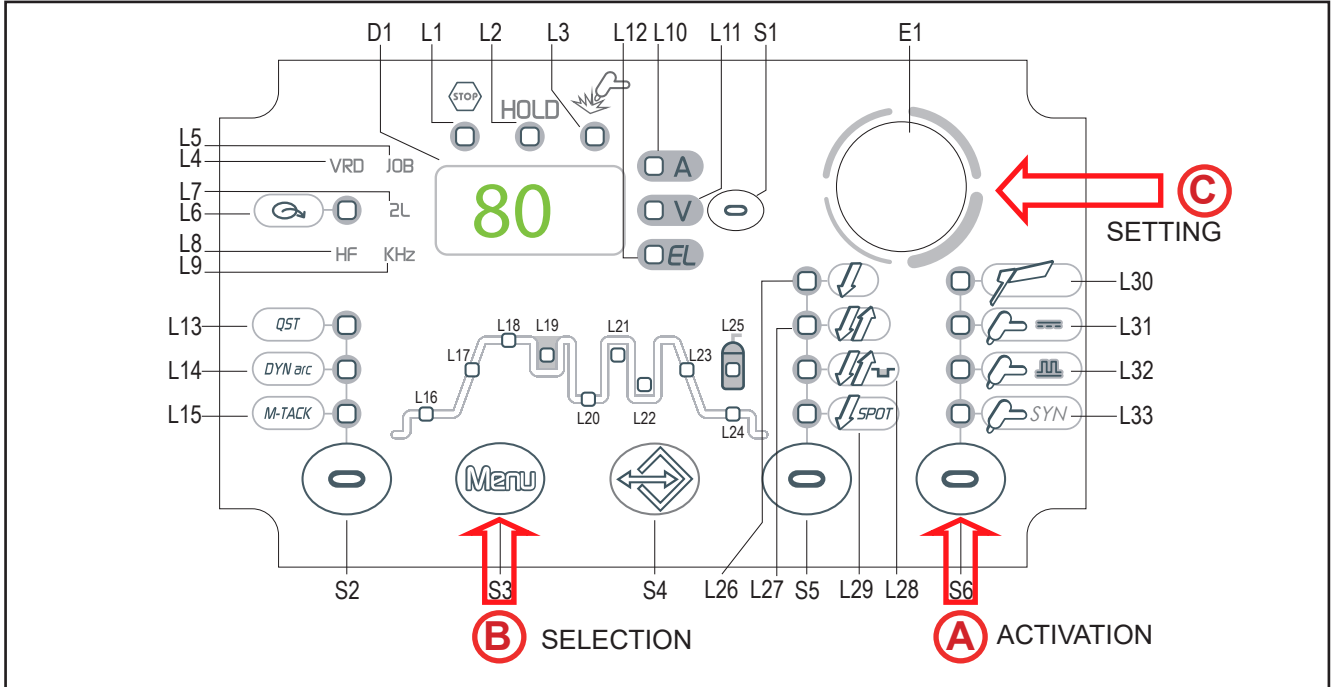

<p>(A)</p>	<ul style="list-style-type: none"> ○ Press the S6 button to activate the MMA mode. <div style="display: flex; align-items: center;"> <div style="margin-right: 20px;"> </div> <div> <p>L30 MMA</p> </div> </div>
<p>(B)</p>	<ul style="list-style-type: none"> ○ Press the S3 button. ○ Use the encoder E1 to scroll the list of settings to be edited. <ul style="list-style-type: none"> ➡ The acronym relative to the selected setting is shown on display D1. ○ Press the S3 button to confirm. <ul style="list-style-type: none"> ➡ The value relative to the selected setting appears on display D1.
<p>(C)</p>	<ul style="list-style-type: none"> ○ Using the encoder E1 to edit the value of the selected setting.

ENGLISH

Tab. 3 - Parameters of 1st level menu: mode

ACRONYM / LED	SETTING	MIN	DEFAULT	MAX	NOTES
L18	WELDING CURRENT MAXIMUM CURRENT WITH REMOTE CONTROL	10 A	80 A	180 A	
Ho.S.	HOT-START	0 %	SYn	100 %	*1 - *2
Ar.F.	ARC FORCE	0 %	SYn	250 %	*1 - *2

***1:** This parameter is set as a percentage referred to the value of the following parameter: **WELDING CURRENT**

***2: SYN:** This code indicates that parameters control is synergic. The optimal value of this parameter is set automatically by the microprocessor on the basis of the preset welding current value. This value can be displayed but it is not user-adjustable.

When **SYN** is installed, to display the synergic value press the following button: **S1**

Press any button  (except **S3**) to save the setting and exit the menu.

- WELDING CURRENT

- o This parameter regulates the primary welding current value.

- MAXIMUM CURRENT WITH REMOTE CONTROL

- o The maximum output current value that can be achieved with foot pedal control external reference.

- HOT-START

- o This parameter aids electrode melting at the time of arc striking. It is set as a percentage referred to the value of the following parameter: **WELDING CURRENT**. The value is limited to maximum 250A.
- Consequences of a higher value:
 - Ease of activation; Greater starting spatter; increase in the activation area.
- Consequences of a lower value:
 - Difficulty of activation; Less starting splatter; Reduction in the activation area.

- ARC-FORCE

- o This parameter helps to avoid electrode sticking during welding. It is set as a percentage referred to the value of the following parameter: **WELDING CURRENT**
- Consequences of a higher value:
 - Fluency factors in welding; Arc welding stability; Increased melting of the electrode within the workpiece; More weld spatter.
- Consequences of a lower value:
 - The arc is extinguished more easily, less welding spatter.

9.2 MMA WELDING - SECOND LEVEL MENU

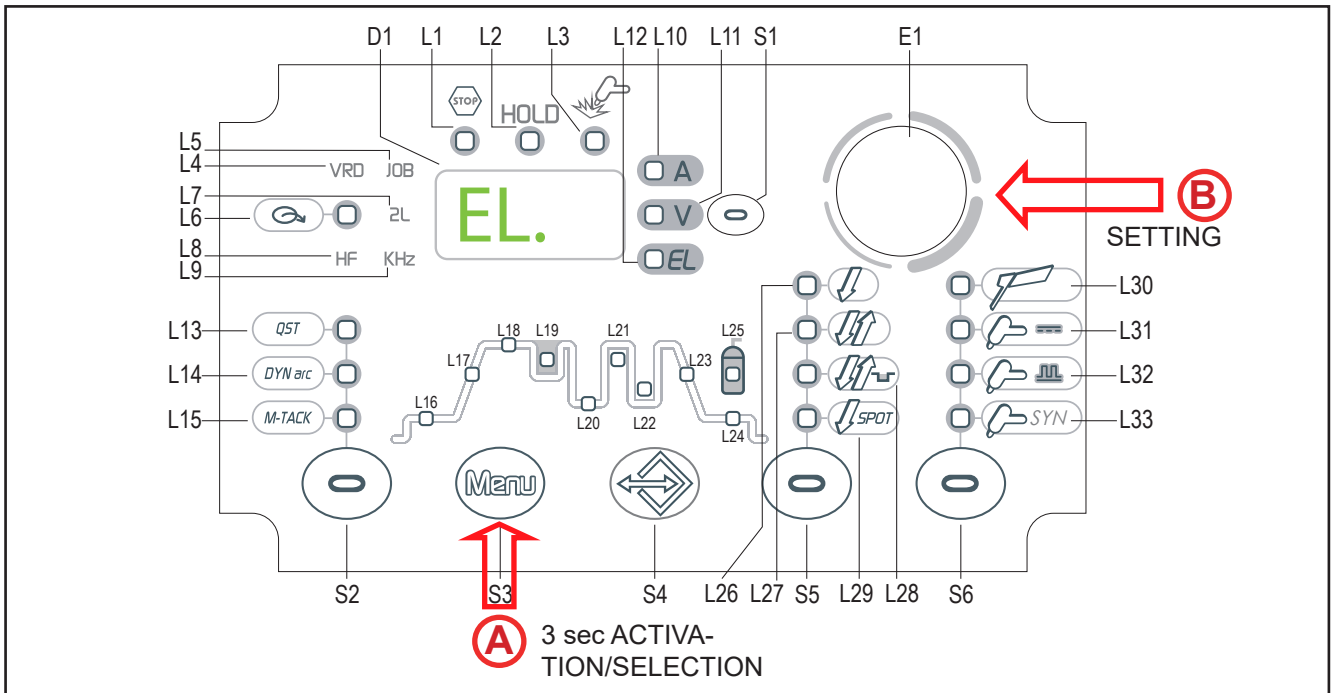

- A
 - Hold down the **S2** (Menu) button for 3 seconds to access the 2nd level menu.
 - **2L** The LED will illuminate.
 - Use the **encoder E1** to scroll the list of settings to be edited.
 - The acronym relative to the selected setting is shown on display **D1**.
 - Press the **S3** (Menu) button to confirm.
 - The value relative to the selected setting appears on display **D1**.
- B
 - Using the **encoder E1**, edit the value of the selected setting.

Tab. 4 - Parameters of the 2nd level menu: MMA mode

ACRONYM / LED	SETTING	MIN	DEFAULT	MAX	NOTES
EL.	ELECTRODE TYPE	-	bAS	-	bAS= basic rUt= rutile Crn= chromium/ nickel ALU= aluminium
Urd	VRD (OUTPUT VOLTAGE REDUCTION)	oFF	oFF	On	*4
U.EL.	LONG ARC VOLTAGE MMA	37	SYn	65	*2
rC	REMOTE CONTROL ACTIVATION	oFF	oFF	On	*3

Press any key (except S3) to save the setting and quit the menu.

***2: SYN:** This code indicates that parameters control is synergic. The optimal value of this parameter is set automatically by the microprocessor on the basis of the preset welding current value. This value can be displayed but it is not user-adjustable.
When **SYN** is installed, to display the synergic value press the following button: **S1**

ENGLISH

***3:** The activation is suitable for the following welding modes:

- MMA
- DC TIG

Compatible remote control types:

- manual remote control.

***4:** The activation is suitable for the following welding modes:

- MMA

- ELECTRODE TYPE

- This parameter allows for the selection of the type of electrode to be used. The selection automatically allows the optimum welding parameters to be set.

- VRD

- This parameter reduces the potential across the welding sockets when welding is not in progress.
- The arc strike procedure is as follows:
 - Touch the workpiece with the electrode tip.
 - Raise the electrode.
 - Power is released for several seconds.
 - Touch the workpiece with the electrode tip.
 - The welding arc will strike.

- LONG ARC VOLTAGE

- This parameter inhibits power output when the potential between electrode and workpiece exceeds the preset threshold level.
- Consequences of a higher value:
 - The welding arc persists even with a significant distance between the electrode and the workpiece.
- Consequences of a lower value:
 - Faster exit from weld.

9.3 MMA WELDING - SPECIAL FUNCTIONS

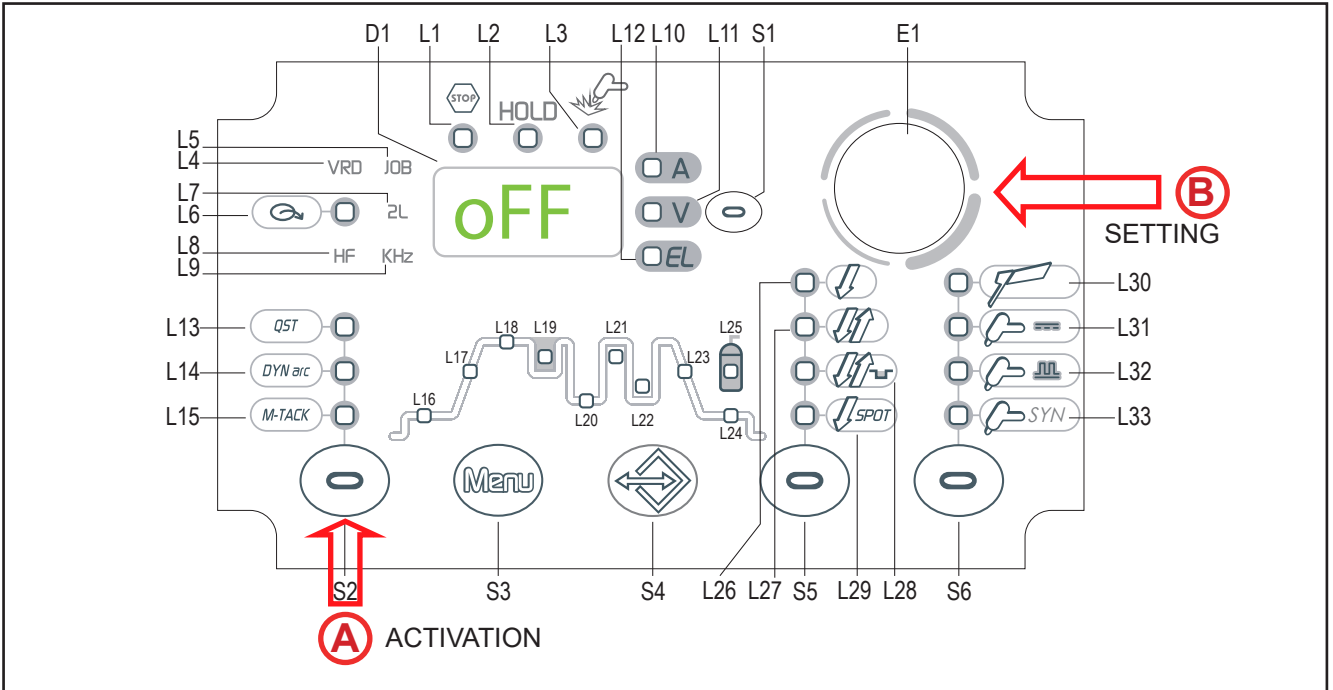

- (A)** ○ Press the **S2** (○) button to scroll the list of settings to edit.
● The value associated with the selected setting appears on display **D1**.
- (B)** ○ Using the **encoder E1** (○), edit the value of the selected setting.

Tab. 5 - Special functions in MMA mode

ACRONYM / LED	SETTING	MIN	DEFAULT	MAX	NOTES
L14	DYNAMIC ARC	oFF	oFF	on	Only MMA

Press any button (○) (except S2) to save the setting and exit the menu.

- DYNAMIC ARC

- Welding power remains constant even when the distance between electrode and workpiece changes.
- Consequences of a higher value:
 - Prevents electrode sticking.
 - Thin workpieces may become deformed more easily.

10 DC TIG WELDING

10.1 DC TIG WELDING - FIRST LEVEL MENU

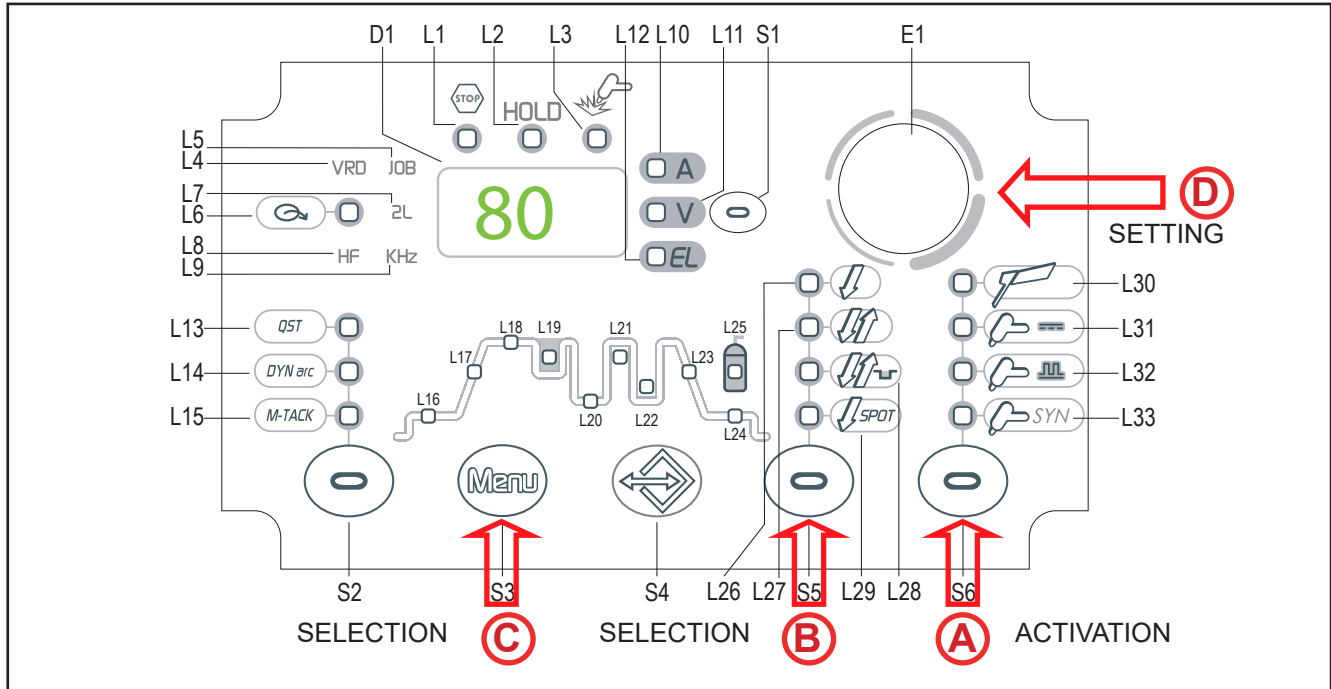

o Press the **S6** button to activate the TIG mode.

(A)		L30	L31 CONTINUOUS TIG DC L32 PULSED TIG DC L33 SYNERGIC TIG DC
		L31	
		L32	
		L33	
		S6	

o Press the **S5** button to select the operation of the desired torch button.

(B)		L26	L26 2 STROKES L27 4 STROKES L28 4 STROKES B-LEVEL L29 2 STROKES SPOT
		L27	
		L28	
		L29	
		S5	

○ Press the **S3** (Menu) button to scroll the list of settings to edit.
 ➔ The value associated with the selected setting appears on display **D1**.

In this diagram the LED relative to the setting to be edited illuminates.

○ Using the **encoder E1**, edit the value of the selected setting.

Press any button (except S3) to save the setting and quit the menu.

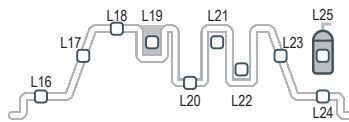

Tab. 6 - Parameters of the 1st level menu: CONTINUOUS DC TIG mode

ACRONYM / LED	SETTING	MIN	DEFAULT	MAX	USEFUL ADVICE
P.xx.	PRE-GAS TIME	0.0 s	0.1 s	9.9 s	Recommended value 0.3 s
L16	STARTING CURRENT	5 A	40 A	200 A	* 2
		2 %	50 %	200 %	* 2
L17	UP SLOPE	0.0 s	0.0 s	25.0 s	Recommended value 0.1 s
L18	WELDING CURRENT MAXIMUM CURRENT WITH RE- MOTE CONTROLLER	5 A	80 A	200 A	
L19	SECOND CURRENT B-LEVEL	10 %	50 %	200 %	* 1
L23	DOWN SLOPE	0.0 s	0.0 s	25.0 s	Recommended value 0.5
L24	FINAL CURRENT	5 A	5 A	170 A	* 2
		5 %	5 %	80 %	* 2
L25	POST GAS TIME	0.0 s	10.0 s	25.0 s	* 3

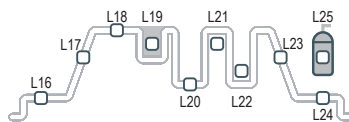

Tab. 7 - Parameters of the 1st level Menu in TIG DC PULSED, TIG DC SYNERGIC PULSED mode.

ACRONYM / LED	SETTING	MIN	DEFAULT	MAX	USEFUL ADVICE
P.xx.	PRE-GAS TIME	0.0 s	0.1 s	9.9 s	Recommended value 0.3 s
L16	STARTING CURRENT	5 A	40 A	200 A	* 2
		2 %	50 %	200 %	* 2
L17	UP SLOPE	0.0 s	0.0 s	25.0 s	Recommended value 0.1 s

ENGLISH

ACRONYM / LED	SETTING	MIN	DEFAULT	MAX	USEFUL ADVICE
L18	WELDING CURRENT MAXIMUM CURRENT WITH RE- MOTE CONTROLLER	5 A	80 A	200 A	
L19	SECOND CURRENT B-LEVEL	10 %	50 %	200 %	* 1
L20	BASE CURRENT	1 %	40 %	200 %	* 1 - * 5
		SYn	SYn	SYn	* 6
L21	PEAK TIME	0.1 s	0.1 s	5.0 s	* 5
		1 %	50 %	99 %	* 4
		SYn	SYn	SYn	* 6
L 21 + L22	PULSED CURRENT FREQUENCY	0.1 Hz	100 Hz	2.5 kHz	* 4
		SYn	SYn	SYn	* 6
L 22	BASE TIME	0.1 s	5.0 s	5.0 s	* 5
L 23	DOWN SLOPE	0.0 s	0.0 s	25.0 s	Recommended value 0.5
L 24	FINAL CURRENT	5 A	5 A	200 A	* 2
		5 %	5 %	80 %	* 2
L 25	POST GAS TIME	0.0 s	10.0 s	25.0 s	* 3

*1: This parameter is set as a percentage referred to the value of the following parameter: **WELDING CURRENT**

*2: The value of this parameter can be set as a percentage of the welding current or as an absolute value expressed in Amperes.

*3: **SYN**: This code indicates that parameters control is synergic. The optimal value of this parameter is set automatically by the microprocessor on the basis of the preset welding current value. This value can be displayed but it is not user-adjustable.

*4: Available when parameter **"PUL" = FA**.

*5: Available when parameter **"PUL" = SLo**.

*6: Available in the following mode: **SYNERGIC TIG**

- **The SYNERGIC PULSED TIG DC** enables a highly concentrated arc to be achieved. It is a very stable arc and moves the pool with strong fluctuations. It is ideal for use in spot welding and the creation of thin fillets. It is recommended for thin layers and in particular where a very stable arc is required (viscous pools)

In this mode, the welding parameters are pulsed: BASE CURRENT; PEAK TIME; PULSED FREQUENCY are only displayed and cannot be modified.

- **PRE-GAS TIME**

- o Time of gas delivery before the arc strike.
- o This adjustment is required when fixing points must be created or when welding in hard-to-reach positions that call for the presence of inert atmospheres before striking the arc.
- Consequences of a higher value:
 - This parameter allows a shielded environment to be created, thereby eliminating contaminants at the start of the welding pass.

- **STARTING CURRENT**

- o Unit current output value immediately after the arc strike. The value of this parameter can be set as a percentage of the welding current or as an absolute value expressed in Amperes. The parameter is displayed but it is not used during the welding process when the following setting is present: MULTI TACK = ON The usefulness of having an adjustable initial welding current is that

of avoiding welding the part with excessively high current values and thus potentially damaging it. Particularly useful when welding thin sheets.

- UP SLOPE

- Time during which the current changes from the starting value to the welding value by means of a slope.
- This setting is used to avoid damaging the edges of the joint with excessively high current values at the moment of arc striking. The value of the main welding current is increased gradually in order to control the uniformity of material deposition and weld penetration. The parameter is not used during the welding process when the following setting is present: MULTI TACK = ON

- WELDING CURRENT

- This parameter regulates the primary welding current value.

- MAXIMUM CURRENT WITH REMOTE CONTROL

- Maximum output current value that can be achieved with remote control external reference.

- SECOND CURRENT B-LEVEL

- With a rapid press and release (less than 0.5 seconds) of the torch trigger during welding, the output current value switches to the value set by means of the "B-level second current" parameter.
- This function makes it possible to avoid interrupting the welding process when the geometry of the workpiece changes; alternatively, the welding current can be reduced to decrease heating of the part if it becomes too hot during execution of the welding process.
- In DC TIG welding, the parameter is useful when welding different gauge workpieces during the same pass; when moving between different gauges the output current can be changed simply by pressing the torch trigger.

- BASE CURRENT

- Pulsed wave minimum current.
- Consequences of a higher value:
 - Faster creation of weld pool.
 - Increase of heat-affected zone.

- PEAK TIME

- Time for which the current pulse is at the maximum value.
- The SET UP, PULSED TYPE=FAST settings, the adjustment is a % of the PULSED CYCLE (CYCLE TIME=1/PULSED FREQUENCY).
- In the settings for SET UP, PULSED TYPE = SLOW, the adjustment is expressed in seconds.
- Consequences of a higher value:
 - Greater width of the beading and greater welding penetration.
 - Facility to make deeper cuts.
- Consequences of a lower value:
 - Reduction of the bead and of heat-affected zone.
 - Difficult to create a weld pool.

- PULSED CURRENT FREQUENCY

- The greater the frequency, the tighter the bead welding and greater the welding time. Increasing the frequency restricts the heat-affected zone. A high frequency (kHz) pulsed arc is suitable for flat beading (head to head or over head)
- Consequences of a higher value:
 - Slower melting speed.
 - Reduction of heat-affected zone.

ENGLISH

- BASE TIME

- Time during which current output is at the base value. Available with settings for SET UP, PULSED TYPE = SLOW, the adjustment is expressed in seconds.
- Consequences of a higher value:
 - The filler material is spread more evenly.
 - Increase of heat-affected zone.

- DOWN SLOPE

- Time during which the current changes from the welding value to the end value by means of a slope. Prevents the formation of craters in the process of turning off the arc. The parameter is not used during the welding process when the following setting is present: MULTI TACK = ON

- FINAL CURRENT

- During electrode welding the parameter makes it possible to obtain a uniform deposit of filler material from the start to the end of the welding process, closing the deposition crater with a current such as to deposit a final droplet of filler material.
- The value of this parameter can be set as a percentage of the welding current or as an absolute value expressed in Amperes.
- The parameter is displayed but it is not used during the welding process when the following setting is present: MULTI TACK = ON
- By keeping the torch trigger pressed during the 3rd stroke, the crater filler current is maintained thereby ensuring optimal crater filling, until the post gas time is started by releasing the torch trigger (4th stroke).

- POST GAS TIME

- Time of post gas delivery when the welding arc is extinguished.
- Consequences of a higher value:
 - More effective pickling (improved appearance of workpiece at the end of the welding pass).
 - Higher gas consumption.
- Consequences of a lower value:
 - Lower gas consumption.
 - Oxidation of electrode tip (more difficult arc strike).

For a better understanding of the parameter functions described in the table, refer to the following diagram.

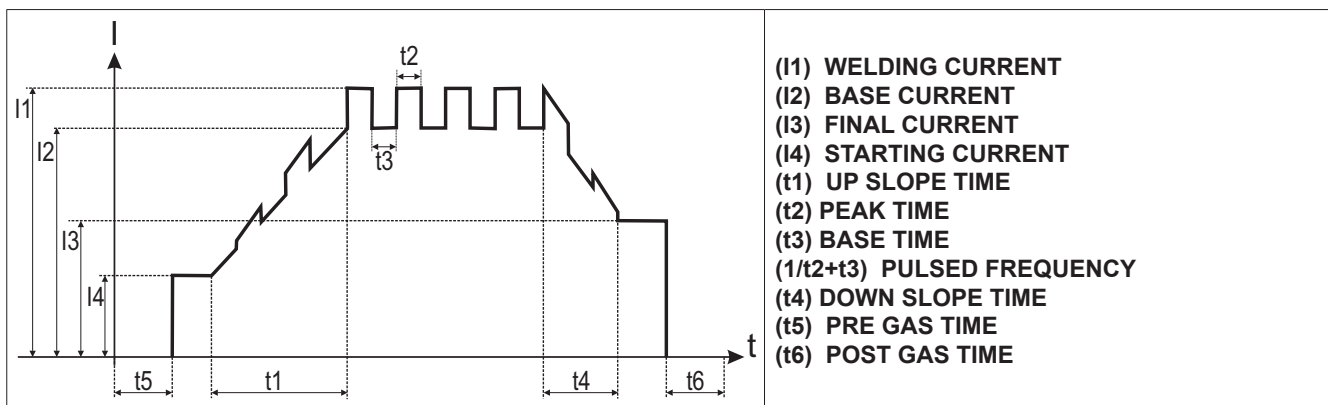

10.2 TIG DC WELDING - SECOND LEVEL MENU

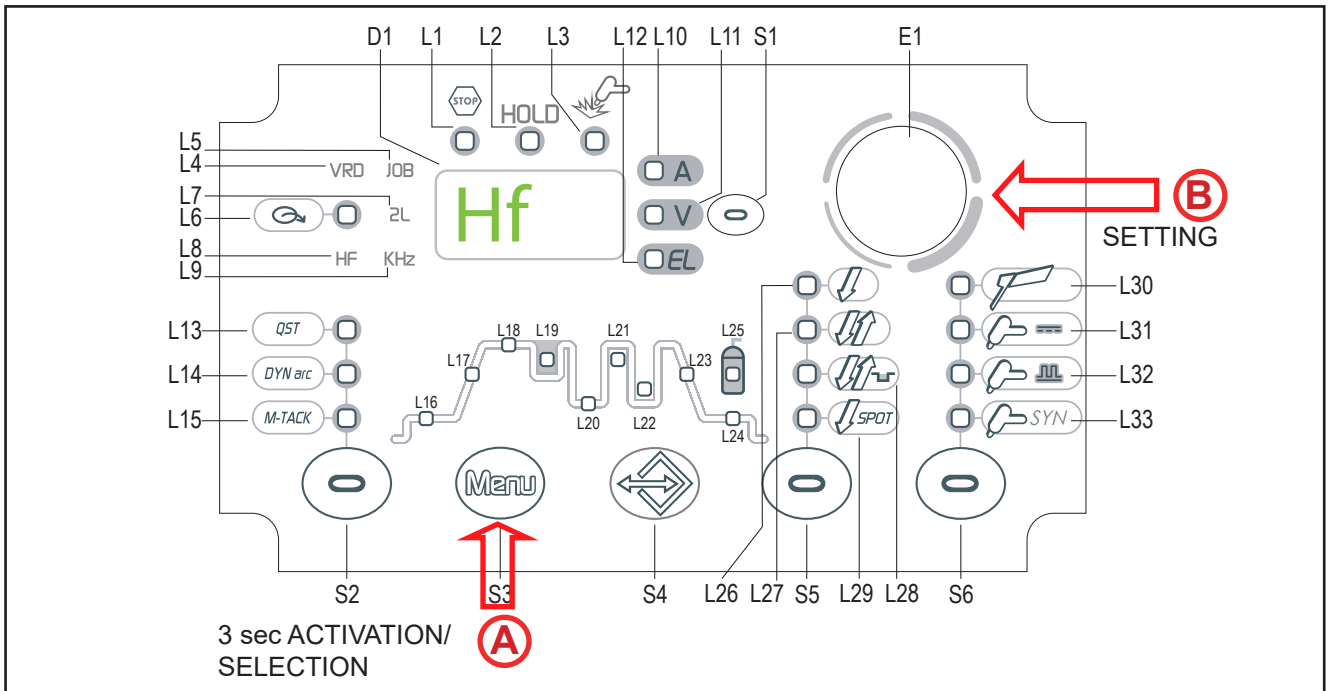

- (A)**
 - Hold down the **S3** (Menu) button for 3 seconds to access the 2nd level menu.
 - **2L** The LED will illuminate.
 - Use the **encoder E1** to scroll the list of settings to be edited.
 - The acronym relative to the selected setting is shown on display **D1**.
 - Press the **S3** (Menu) button to confirm.
 - The value associated with the selected setting appears on display **D1**.
- (B)**
 - Using the **encoder E1** to edit the value of the selected setting.

Tab. 8 - Parameters of the 2nd level menu: DC TIG mode

ACRONYM / LED	SETTING	MIN	DEFAULT	MAX	NOTES
SP.t.	SPOT TIG TIME	0.01 s	0.01 s	10.0 s	Only with 2 STROKE SPOT
HF	ENABLE HF ARC STRIKE	On	On	oFF	
r.P.C.	MINIMUM PEDAL CURRENT	1 %	5 %	90 %	*2
rC	REMOTE CONTROL ACTIVATION	oFF	oFF	On	*1

Press any button (except S3) to save the setting and quit the menu.

*1: The activation is suitable for the following welding modes:

- MMA
- DC TIG





Compatible remote control types:

- manual remote control.
- UP/DOWN or potentiometer TIG torch.
- foot pedal controller.

ENGLISH

The maximum and minimum TIG welding current values can be set with the foot pedal control. The up and down slopes cannot be controlled via the foot pedal.

The following welding procedures can be selected with the foot pedal:

	 + HF		 + HF
2T LIFT-ARC	2T HF	2T SPOT	2T SPOT + HF

If both remote controls are connected, the foot pedal assumes priority over the UP/DOWN or potentiometer TIG torch.

When this function is active welding is performed without the following parameters:

- UP SLOPE
- DOWN SLOPE
- All special functions

*2: This parameter is set as a percentage referred to the value of the following parameter: WELDING CURRENT

- SPOT TIG TIME

- Available only with 2 STROKE SPOT When the torch trigger is pressed the welding arc persists for the time set in the parameter. Press the torch trigger again to resume the welding process.
- The result of this is a very precise, not oxidized welding spot without any plastic deformation of the sheet.

- HF ARC START

- This parameter enables the arc strike in the TIG welding procedure by means of a high frequency (HF) current discharge. The high frequency arc strike (HF) prevents the inclusion of impurities at the start of the weld pass. If set to OFF, the ignition will be of a 'LIFT ARC' strip type
 - **HF:** This type of ignition occurs by means of a high-voltage electric discharge but of low amperage (HF) between the electrode tip and the weld workpiece. Once the electric arc is established the generator stops delivering the HF charge. This type of ignition in addition to being very easy and immediate, allows the electrode life to be extended and to keep it very pure allowing the operator to work with a very precise and stable arc.

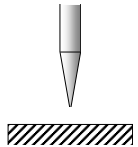
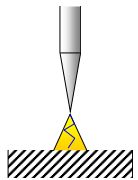
HF ARC IGNITION PROCEDURE		
1		Position the tungsten electrode on the ignition point, so that there is a distance of about 2-3 mm between the electrode and the workpiece
2		Press the torch button according to the mode selected. The voltaic arc ignites without touching the weld workpiece.

- **LIFT-ARC:** This type of arc blow is derived from a short low-amperage circuit (to avoid electrode damage) that the operator created between the electrode tip and the workpiece and the consequent rise of the electrode tip that maintains the current flow by creating the so-called electric arc. It is advisable to use LIFT-ARC priming in applications such as maintenance of

machinery in operation, welding close to printed circuits or soldering near computers.

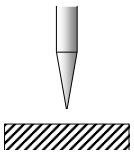
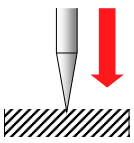
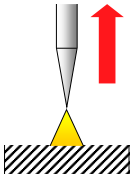
PROCESS FOR ARC IGNITION IN LIFT-ARC MODE:		
1		Position the tungsten electrode on the ignition point, so that there is a distance of about 2-3 mm between the electrode and the workpiece
2		Touch the piece with the electrode and press the torch button according to the mode selected.
3		Lift the torch to strike the arc.

- MINIMUM PEDAL CURRENT

- Minimum output current value with foot pedal controller external reference. The current is set as a percentage with respect to the "maximum foot pedal current" parameter.

10.3 TIG DC WELDING - SPECIAL FUNCTIONS MENU

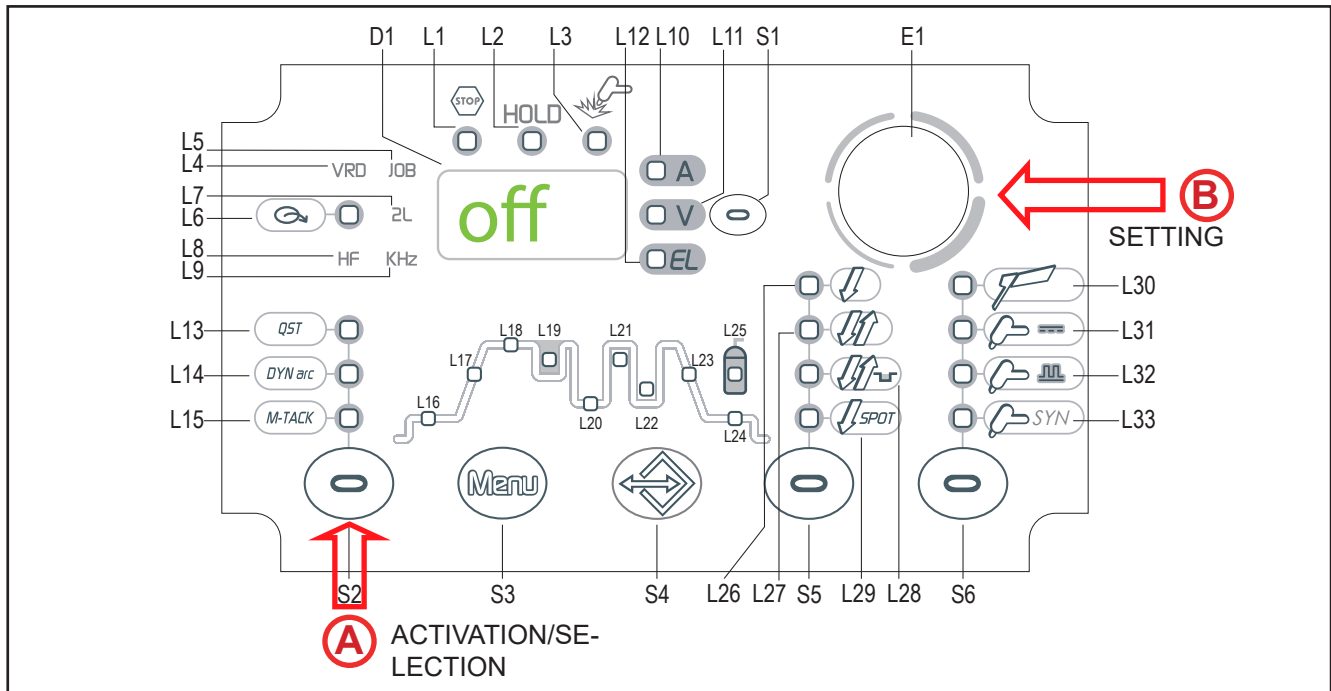

- (A)** ○ Press the **S2** button to scroll the list of settings to edit.
● The value associated with the selected setting appears on display **D1**.
- (B)** ○ Using the **encoder E1** , edit the value of the selected setting.

Tab. 11 - Special functions in MMA mode

ACRONYM / LED	SETTING	MIN	DEFAULT	MAX	NOTES
L13	Q-START	0.1 s	oFF	60 s	*3 See Table 12
L14	DYNAMIC ARC	oFF	oFF	On	*3 See Table See Table 13 (not with SYNERGIC PULSED TIG)
L15	MULTI TACK	0.5 Hz	oFF	6.0 Hz	*2 - *3 See Table See Table 14 (not with SYNERGIC PULSED TIG)

Press any button (except **S2**) to save the setting and exit the menu.

***2:** When this function is active welding is performed without the following parameters:

- UP SLOPE
- DOWN SLOPE
- STARTING CURRENT
- FINAL CURRENT
- DYNAMIC ARC
- Q-START

***3:** When "rC2= ON and a foot pedal control is connected, all functions are inhibited.

- Q-START

- This parameter allows the unit to start in synergic pulsed TIG mode for the preset time interval, before switching automatically to the welding procedure selected on the interface panel. The parameter creates the weld pool more quickly than a standard starting time of the material because it creates a movement of the two flaps up to speed up the join.
- This parameter is useful when spot welding thin gauge sheet.

Tab. 12 - Recommended Q-START parameters

CORNER/BUTT JOINT		
Sheet thickness (mm)	Current (A)	Q start value (seconds)
1.0 mm	35 A - 50 A	0.5 - 1.0
2.0 mm	50 A - 80 A	
3.0 mm	80 A - 140 A	
4.0 mm	140 A - 170 A	

- DYNAMIC ARC

- This function allows, on the reduction of the arc voltage, an increase of the welding current and vice versa. The amount of DynamicArc variation can be individually adjusted for a value between 1 A and 50 A. For example, an increase of 50A for a 1 volt variation.
- This value must be set depending on the material thickness, and the type of processing to be carried out (values between 1 A and 20 A for thin layers while a value between 20 A and 50 A for medium-thick layers).
- Welding power remains constant even when the distance between electrode and workpiece changes.
- Consequences of a higher value:
 - The welding arc concentration remains unchanged.
 - Prevents electrode sticking.
 - Increased welding speed.
 - Minor plastic deformity in the welded workpiece.
 - Greater penetration at the apex.
 - Concentrated heat contribution only to the welding and not to the surrounding area.
 - Minor oxidation of the piece and therefore lower post-weld re-work costs.
 - Better control of first application in gaps (useful for pipe fitters and installers).
 - Ease of welding even for pieces which are not properly prepared.
 - Minimization of errors and greater arc stability with motion variations.

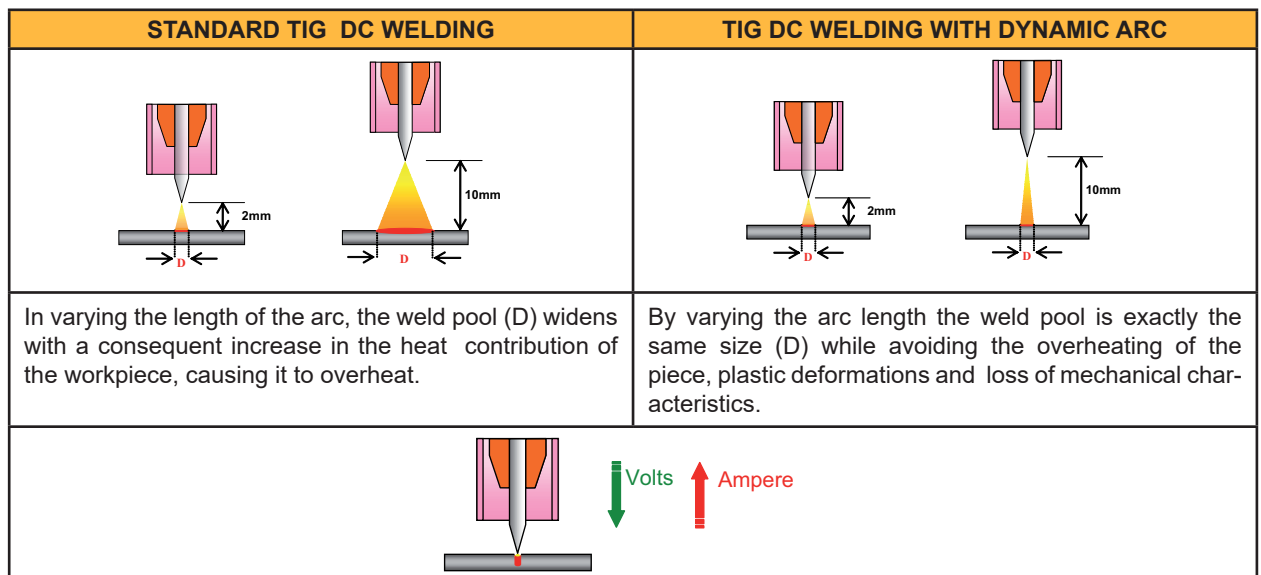

ENGLISH

Tab. 13 - Recommended DYNAMIC ARC parameters

ANY TYPE OF JOINT		
Sheet thickness (mm)	Current (A)	DynArc Value (Amperes)
1,0 mm	35 A - 50 A	5 - 10
2,0 mm	50 A - 80 A	10 - 15
3.0 mm	80 A - 140 A	15 - 25
4.0 mm	140 A - 170 A	25 - 50

In order to have optimum control of the arc, it is advisable to ignite it at a distance of between 4-5 mm from the initial point of the joint (point zero) .

- MULTI TACK

- This consists of continual welding that allows optimum control of the thinnest layers and sheets/bevels with irregular shapes.
- **Benefits:**
 - Major reduction in oxidisation with the absence of deformations.
 - This parameter allows thin gauge sheet to be welded without deformation.
- **Consequences of a higher value:**
 - Welding of thinner gauge sheet without deformation.
 - Less melting of material, slower welding process.

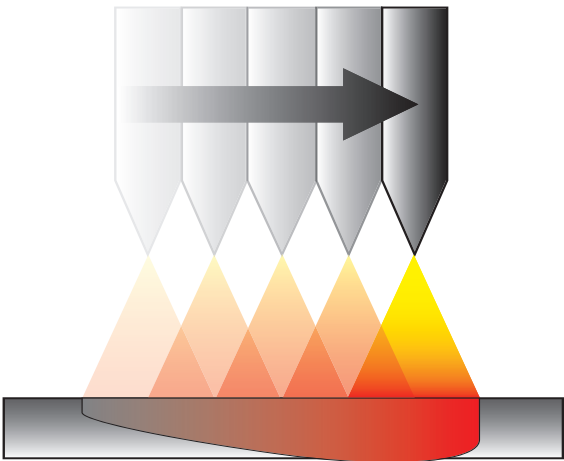
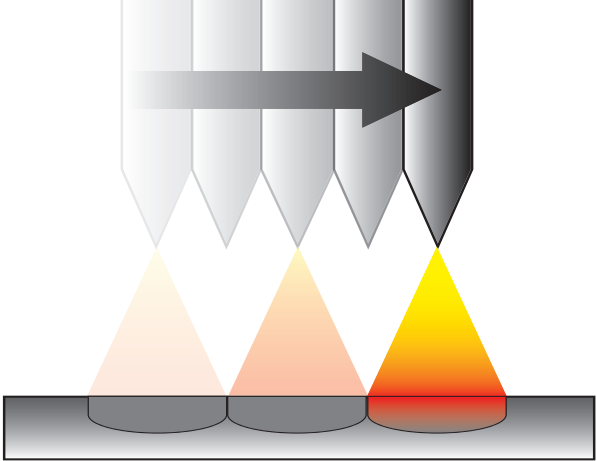
TIG DC WELDING CONTINUOUS	TIG DC WELDING WITH MULTITACK
	
<p>Continuous TIG welding provides continuous energy which prevents the cooling of the piece and does not cause overheating with excessive penetration and excessive distortion effects. Using the pulsed TIG reduces the effect of overheating but it does not solve it completely as the arc will remain on and will still provide energy and heat.</p>	<p>The series of triggers repeated over time allow the piece to disperse the heat between a trigger and another. By adjusting the MultiTack frequency the weld penetration, speed' of execution and in particular the control of the heat input can be optimised as well as any consequent deformation of the piece.</p>
<p>When welding corner joints, the Multitack may be used with excellent results. The welding remains white and free of any oxidation often avoiding the post welding cleanup treatment with acids.</p>	

Tab. 14 - Recommended MULTITACK parameters

CORNER/BUTT JOINT		
Sheet thickness (mm)	Current (A)	Multitack FREQUENCY (Hz)
0.6 mm	40 A - 60 A	1.0 - 1.5
0.8 mm	60 A - 80 A	1.0 - 1.5
1.0 mm	80 A - 100 A	1.0 - 1.5
1.5 mm	90 A - 110 A	1.0 - 1.5
2.0 mm	110 A - 130 A	1.0 - 1.5
	130 A - 150 A	1.5 - 2.0
2.5 mm	150 A - 160 A	1.0 - 1.5
	160 A - 170 A	1.5 - 2.0
3.0 mm	170 A - 180 A	1.0 - 1.5
	180 A - 200 A	1.5 - 2.0

- It is recommended that a pre-gas time of between 0.3 - 0.5 seconds be used in order to have optimum protection right from the ignition, thus avoiding the oxidation of the initial part of the weld. This is also the same for the final part where it is recommended that a post gas time not less than 3 seconds is used.

11 TORCH TRIGGER PROCEDURE

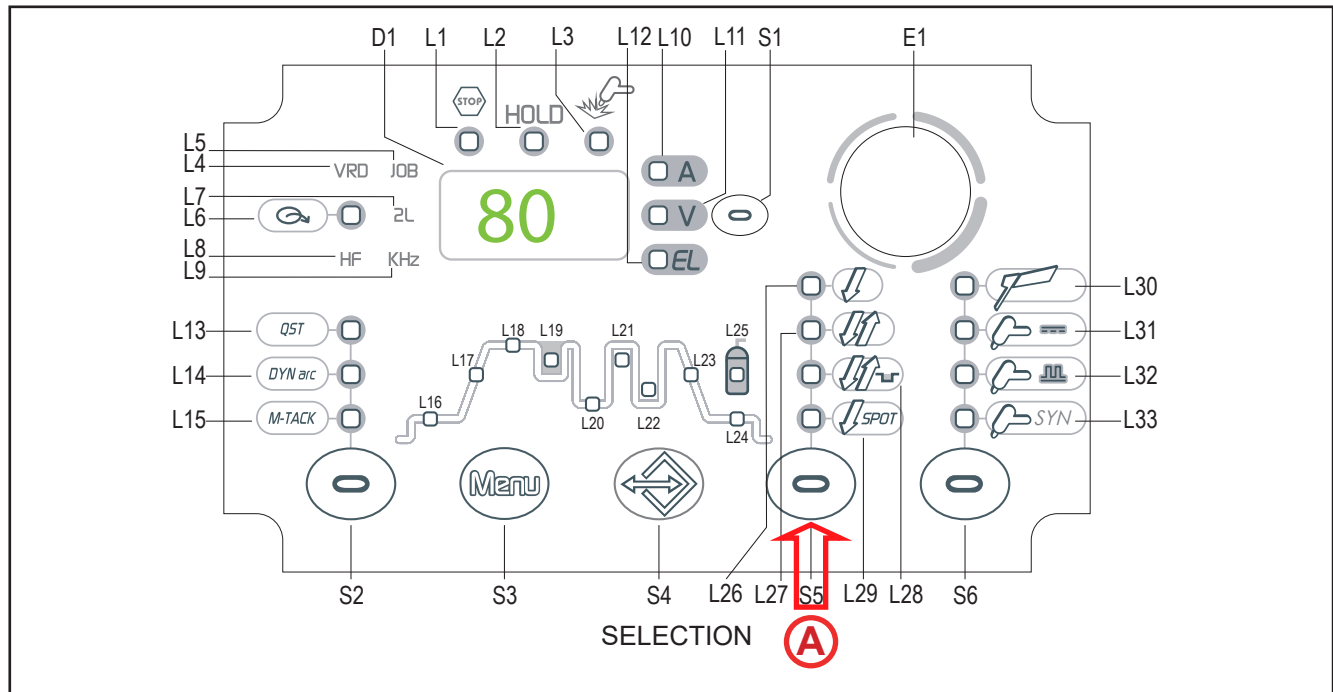

○ Press the **S5** button to select the desired PULSED TORCH mode.

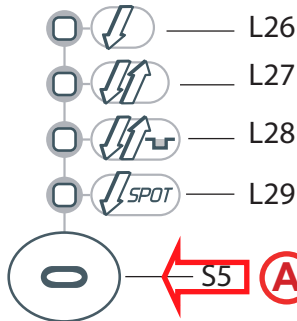

L26 2 STROKE
L27 4 STROKE
L28 4 STROKE B-LEVEL
L29 2 STROKE SPOT

Depending on the welding mode selected, specific torch procedures are available. The availability of certain procedures depends on whether or not certain parameters or functions of the unit are enabled or set in the associated menus.
The table shows the settings to be made to enable each procedure.

LEGEND

- 2T:** _____ 2 STROKE LIFT-ARC
- 2T HF:** _____ 2 STROKE WITH HIGH FREQUENCY ARC STRIKE (HF)
- 4T:** _____ 4 STROKE LIFT-ARC
- 4T HF:** _____ 4 STROKE WITH HIGH FREQUENCY ARC STRIKE (HF)
- 4T B-L:** _____ 4 STROKE B-LEVEL
- 4T B-L HF:** _____ 4 STROKE B-LEVEL WITH HIGH FREQUENCY ARC STRIKE (HF)
- 2T Q-SPOT:** _____ 2 SPOT STROKE
- 2T Q-SPOT HF:** _____ 2 SPOT STROKE WITH HIGH FREQUENCY ARC STRIKE (HF)
- √: _____ Always available.
- 1: _____ Available with the following setting: HF= on

Tab. 16 - Pulsed Torch trigger mode table.

→ ↓	PROCEDURE							
MODE	2T	2T HF	4T	4T HF	4T B-L	4T B-L HF	2T Q-SPOT	2T Q-SPOT HF
 MMA								
 AD GOUGING ELECTRODE								
 DC TIG CONTINUOUS	√	1	√	1	√	1	√	1
 DC TIG PULSED MODE	√	1	√	1	√	1	√	1
 SYNERGIC PULSED DC TIG	√	1	√	1	√	1	√	1

- 2 STROKE LIFT:

- Touch the workpiece with the torch electrode.
- Press (1T) and keep the torch trigger pressed.
- Slowly lift the torch to strike the arc.
- The welding current reaches the preset value, by way of a up slope time, if programmed.
- Release (2T) trigger to start the weld completion procedure.
- The current reaches the end current value in the time set in the down slope time parameter.
- The arc is extinguished.
- Gas delivery continues for the time set in the post gas parameter.

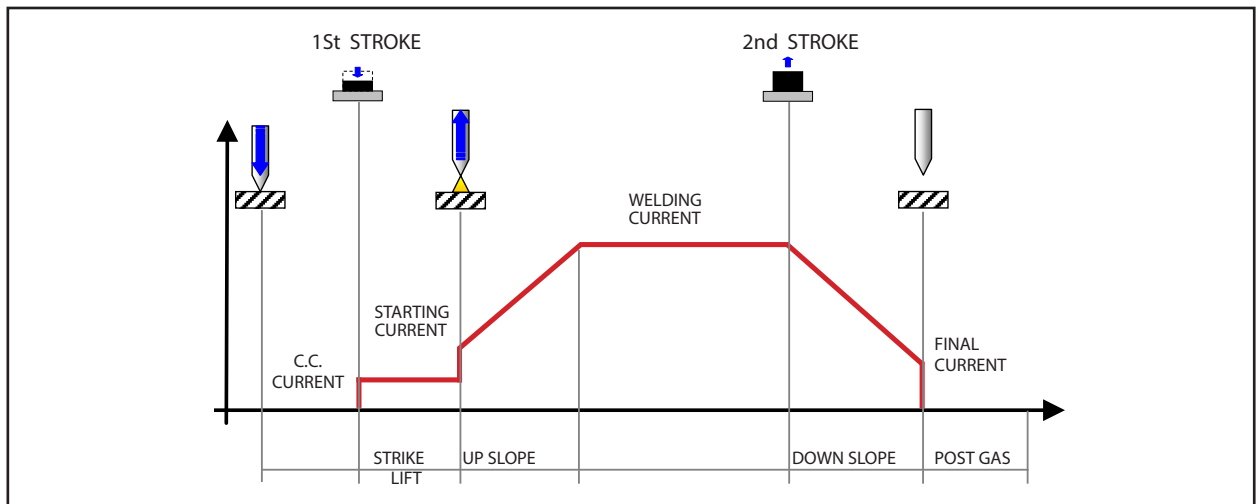

ENGLISH

- 2 STROKE + HF

- Bring the torch up to the work until the electrode tip is approximately 2 or 3 mm away.
- Press (1T) and keep the torch trigger pressed.
- The arc strikes without contact with the workpiece and the voltage discharges (HF) cease automatically.
- The welding current reaches the preset value, by way of a up slope time, if programmed.
- Release (2T) trigger to start the weld completion procedure.
- The current reaches the end current value in the time set in the down slope time parameter.
- The arc is extinguished.
- Gas delivery continues for the time set in the post gas parameter.

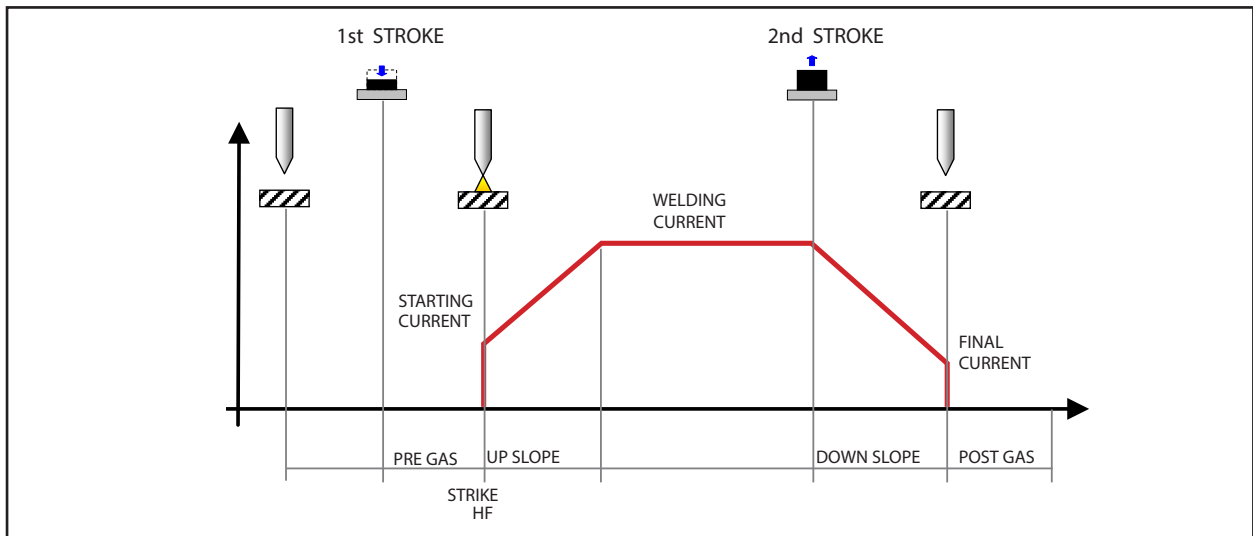

- 4 STROKE LIFT:

- Touch the workpiece with the torch electrode.
- Press (1T) and keep the torch trigger pressed.
- Slowly lift the torch to strike the arc.
- The arc strikes, the welding current assumes the pilot current value. (if activated from the SET UP menu.)
- Release (2T) the torch trigger.
- The welding current reaches the preset value, by way of a up slope time, if programmed.
- Press (3T) trigger and keep it pressed to start the weld completion procedure.
- The current reaches the end current value in the time set in the down slope time parameter.
- The arc continues and the current output will be the value set in the end current parameter.
- In these conditions the weld pool can be closed (crater filler current).
- Release (4T) trigger to extinguish the arc.
- Gas delivery continues for the time set in the post gas parameter.

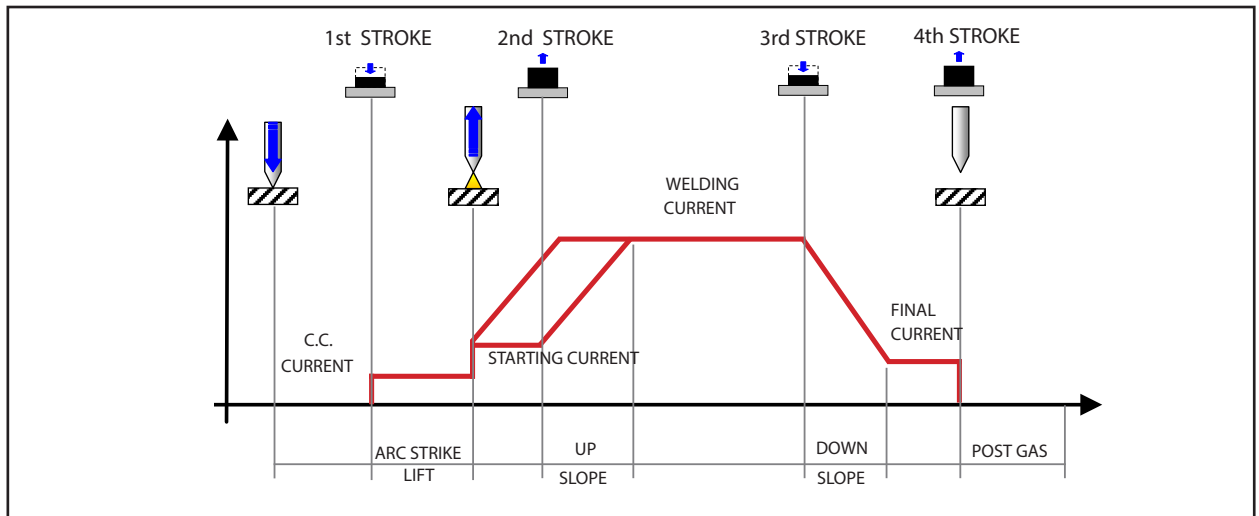

- 4 STROKE + HF

- Bring the torch up to the work until the electrode tip is approximately 2 or 3 mm away.
- Press (1T) and keep the torch trigger pressed.
- The arc strikes without contact with the part and the voltage discharges (HF) cease automatically, the welding current will assume the pilot current value. (if activated from the SET UP menu.)
- Release (2T) torch trigger.
- The welding current reaches the preset value, by way of a up slope time, if programmed.
- Press (3T) trigger and keep it pressed to start the weld completion procedure.
- The current reaches the end current value in the time set in the down slope time parameter.
- The arc continues and the current output will be the value set in the end current parameter.
- In these conditions the weld pool can be closed (crater filler current).
- Release (4T) the trigger to extinguish the arc.
- Gas delivery continues for the time set in the post gas parameter.

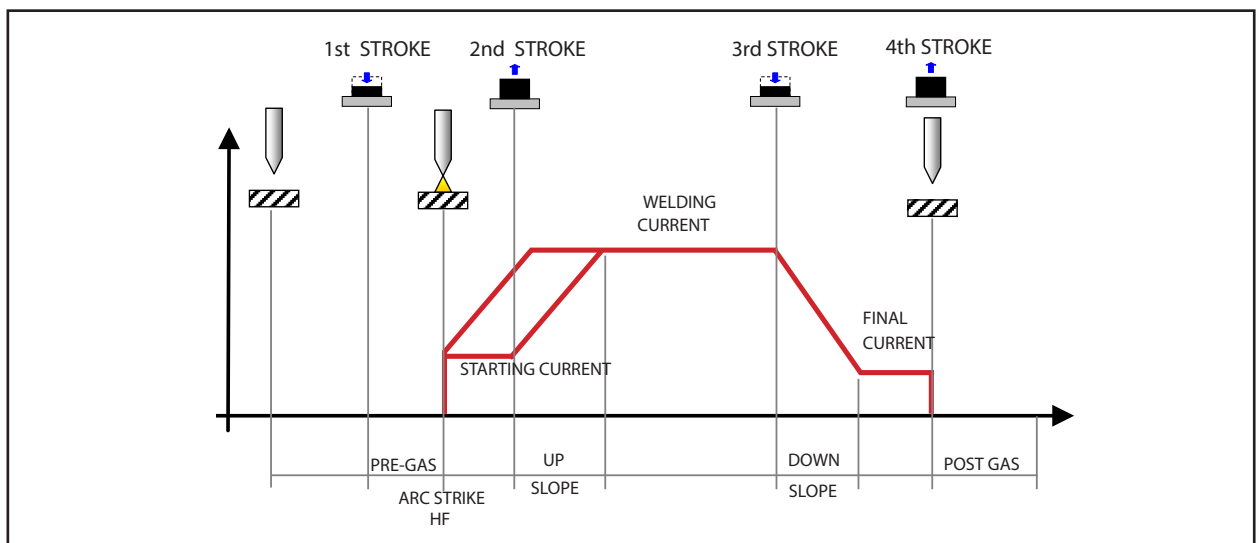

ENGLISH

4 STROKE B-LEVEL LIFT:

- Touch the workpiece with the torch electrode.
- Press (1T) and keep the torch trigger pressed.
- Slowly lift the torch to strike the arc.
- The arc strikes, the welding current assumes the pilot current value. (if activated from the SET UP menu.)
- Release (2T) torch trigger.
- The welding current reaches the preset value, by way of a up slope time, if programmed.
- Press and immediately release the torch trigger to switch to the second welding current.
- The trigger must not be pressed for more than 0.3 seconds; otherwise, the weld completion stage will start.
- When the trigger is pressed and released immediately, the system returns to the welding current.
- Press (3T) trigger and keep it pressed to start the weld completion procedure.
- The current reaches the end current value in the time set in the down slope time parameter.
- The arc continues and the current output will be the value set in the end current parameter.
- In these conditions the weld pool can be closed (crater filler current).
- Release (4T) trigger to extinguish the arc.
- Gas delivery continues for the time set in the post gas parameter.

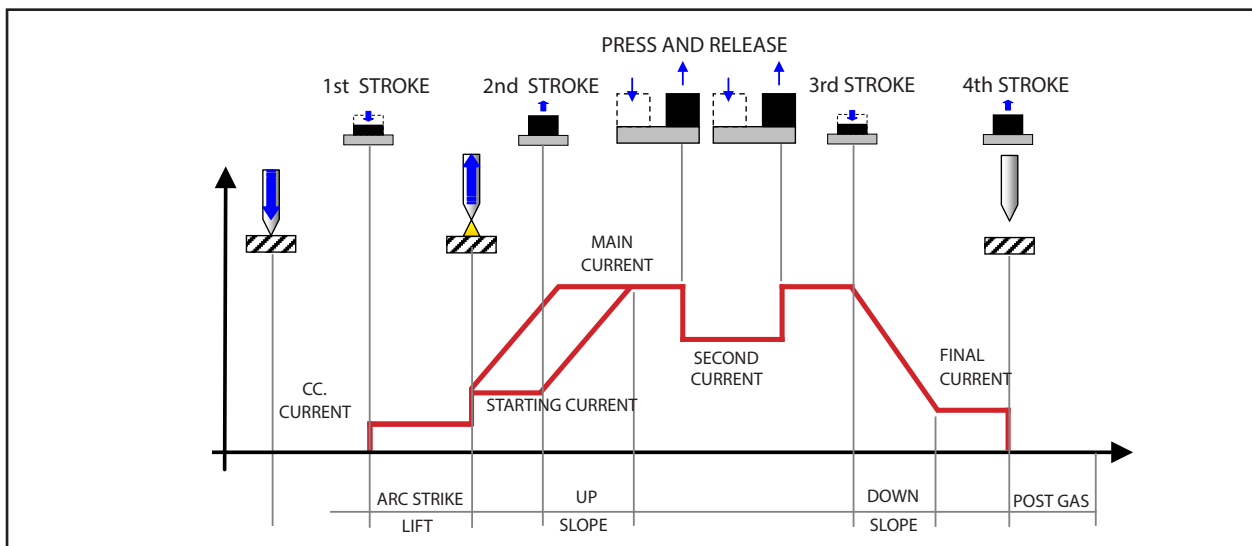

- 4 STROKE B-LEVEL:

- Bring the torch up to the work until the electrode tip is approximately 2 or 3 mm away.
- Press (1T) and keep the torch trigger pressed.
- The arc strikes without contact with the part and the voltage discharges (HF) cease automatically, the welding current will assume the pilot current value. (if activated from the SET UP menu.)
- Release (2T) torch trigger.
- The arc strikes without contact with the workpiece and the voltage discharges (HF) cease automatically.
- The welding current reaches the preset value, by way of a up slope time, if programmed.
- Press and immediately release the torch trigger to switch to the second welding current.
- The trigger must not be pressed for more than 0.3 seconds; otherwise, the weld completion stage will start.
- When the trigger is pressed and released immediately, the system returns to the welding current.
- Press (3T) trigger and keep it pressed to start the weld completion procedure.
- The current reaches the end current value in the time set in the down slope time parameter.
- The arc continues and the current output will be the value set in the end current parameter.
- In these conditions the weld pool can be closed (crater filler current).
- Release (4T) trigger to extinguish the arc.
- Gas delivery continues for the time set in the post gas parameter.

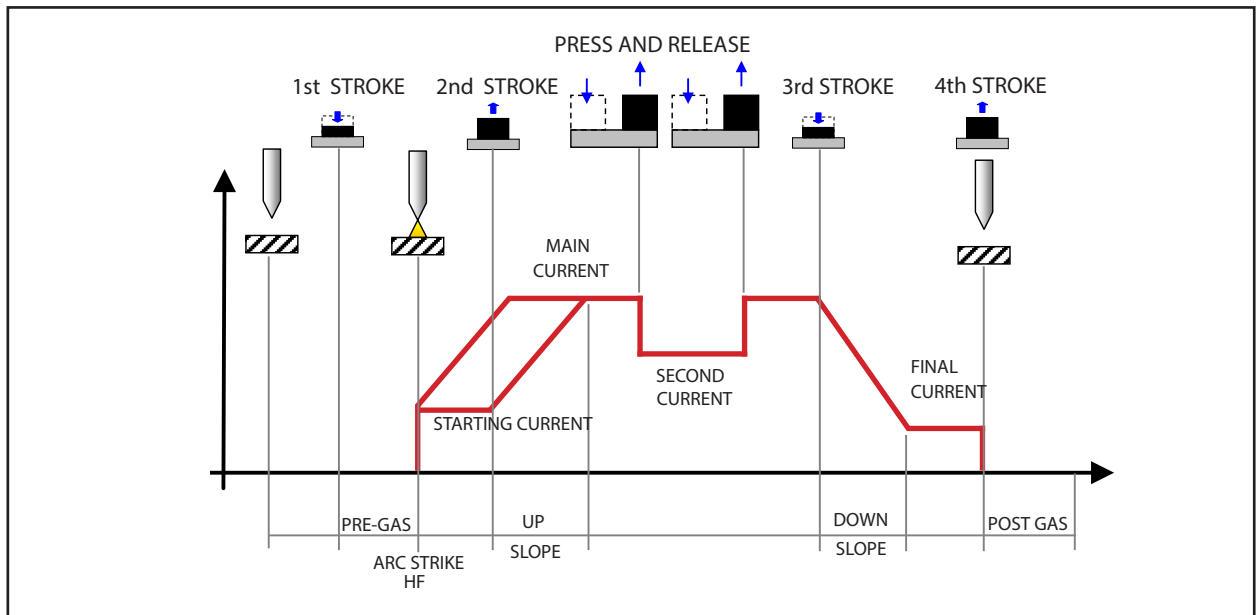

- PILOT ARC WELDING:

The pilot arc can be activated in the following torch trigger procedures:

- 4T LIFT-ARC WELDING
- 4 TIMES + HF WELDING (4T HF)
- 4 TIMES BI-LEVEL + HF WELDING (4T BI-LEVEL HF)

The welding procedure with pilot arc differs with respect to the procedure without pilot arc in the part of the torch trigger procedure described below.

LIFT-ARC Welding

- Touch the workpiece with the torch electrode.
- Press (1T) and keep the torch trigger pressed.
- Slowly lift the torch to strike the arc.
- The arc strikes, the welding current assumes the pilot current value.
- Release (2T) the torch trigger.
- The welding current reaches the preset value, by way of a up slope time, if programmed.
- etc.

Welding with HF

- Press (1T) and keep the torch trigger pressed.
- The arc strikes without contact with the part and the voltage discharges (HF) cease automatically, the welding current will assume the pilot current value.
- Release (2T) the torch trigger.
- The welding current reaches the preset value, by way of a up slope time, if programmed.
- etc.

11.1 2 STROKE SPOT - Q-SPOT FUNCTION

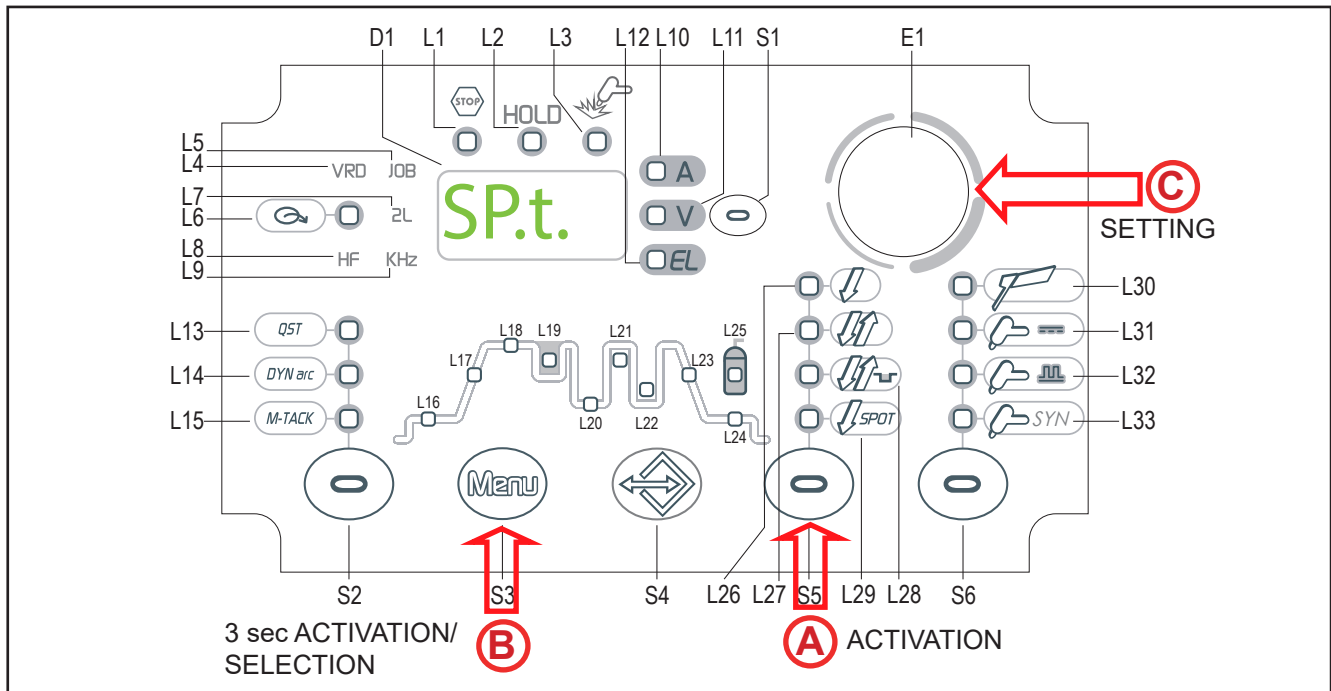

- (A)** ○ Press the **S5** button to select the TORCH 2 STROKE SPOT BUTTON mode.
- (B)** ○ Hold down the **S2** button for 3 seconds to access the 2nd level menu.
 - **2L** The LED will illuminate.
- Use the **encoder E1** to scroll the list of settings to be edited. Select SP.t. SPOT-WELDING TIME
 - The acronym associated with the selected setting is shown on display **D1**.
- Press the **S3** button to confirm.
 - The value associated with the selected setting appears on display **D1**.
- (C)** ○ Using the **encoder E1** , edit the value of the selected setting.

Tab. 17 - Parameters of the 2nd level menu: 2 STROKE SPOT mode

ACRONYM / LED	SETTING	MIN	DEFAULT	MAX	NOTES
SP.t.	SPOT TIG TIME	0.01 s	0.01 s	10.0 s	Only with 2 STROKE SPOT

- Press any button (except **S3**) to save the setting and quit the menu

- Q-SPOT

- This function, only present in 2 STROKE SPOT, facilitates spot-welding:
 - It allows the exact positioning of the electrode at the point to be joined. The electrode is conveniently placed at the desired location.
 - Only after lifting of the electrode, the machine emits pulse welding for the stipulated time.
 - It considerably reduces the risk of contamination of the joint with the electrode.
 - While pressing the torch button, the process may be repeated as many times as required.

- This function is ideally suited to the welding of thinner gauges, head to head position and the pipes. Place the torch with the electrode on the precise point to be fixed.
 - Press the torch trigger and then lift.
 - After lifting the torch, a precise trigger will follow.
- **Recommended:** Set the highest current possible with the lowest possible time. Value: 0.01-0.5 sec.
- **Warning:** it is important to check the up and down slopes are null (0sec.)
- The Q-Spot function has a dual mode, i.e. it is possible to carry out spot welding without contact with the piece.
 - It is recommended that the spot-welding position is researched (an electrode that contacts the workpiece) for thin layers (less than 1.5 mm) while for greater thicknesses, without making contact with the workpiece.

- 2 STROKE SPOT LIFT:

- Touch the workpiece with the torch electrode.
- Press (1T) and keep the torch trigger pressed.
- Slowly lift the torch to strike the arc.
- Release (2T) torch trigger.
- The welding current reaches the preset value, by way of a up slope time, if programmed.
- The welding procedure continues, at the preset current, for the time set with the spot time parameter.
- The current reaches the end current value in the time set in the down slope time parameter.
- The arc is extinguished.
- Gas delivery continues for the time set in the post gas parameter.

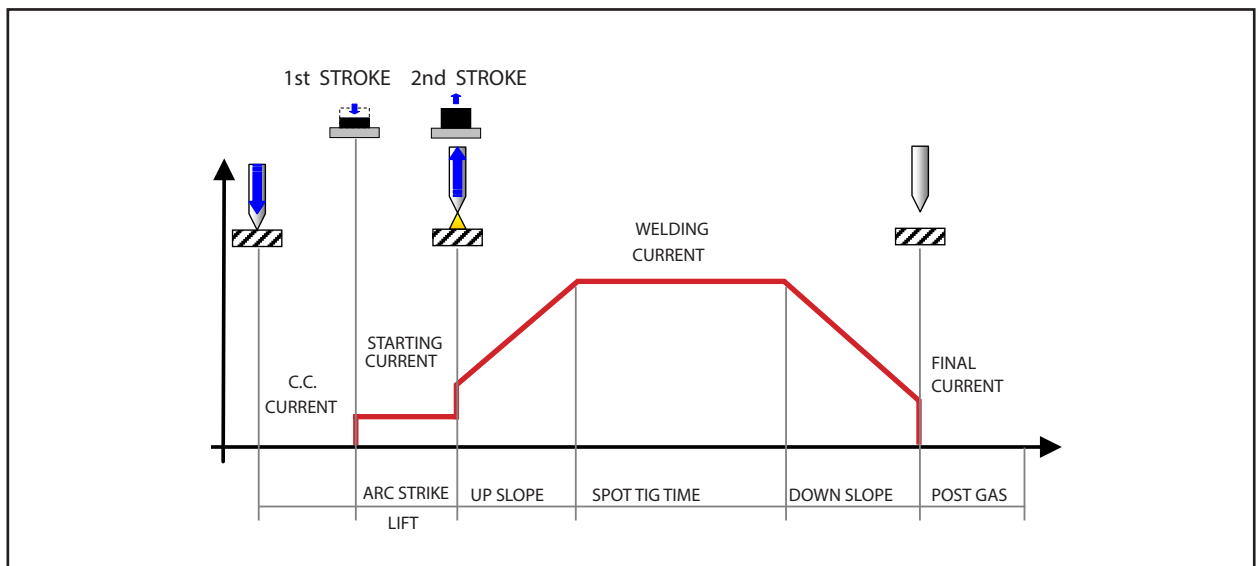

ENGLISH

- 2 STROKE SPOT HF:

- Bring the torch up to the work until the electrode tip is approximately 2 or 3 mm away.
- Press (1T) torch trigger.
- The arc strikes without contact with the workpiece and the voltage discharges (HF) cease automatically.
- Release (2T) torch trigger.
- The welding current reaches the preset value, by way of a up slope time, if programmed.
- The welding procedure continues, at the preset current, for the time set with the spot time parameter.
- The current reaches the end current value in the time set in the down slope time parameter.
- The arc is extinguished.
- Gas delivery continues for the time set in the post gas parameter.

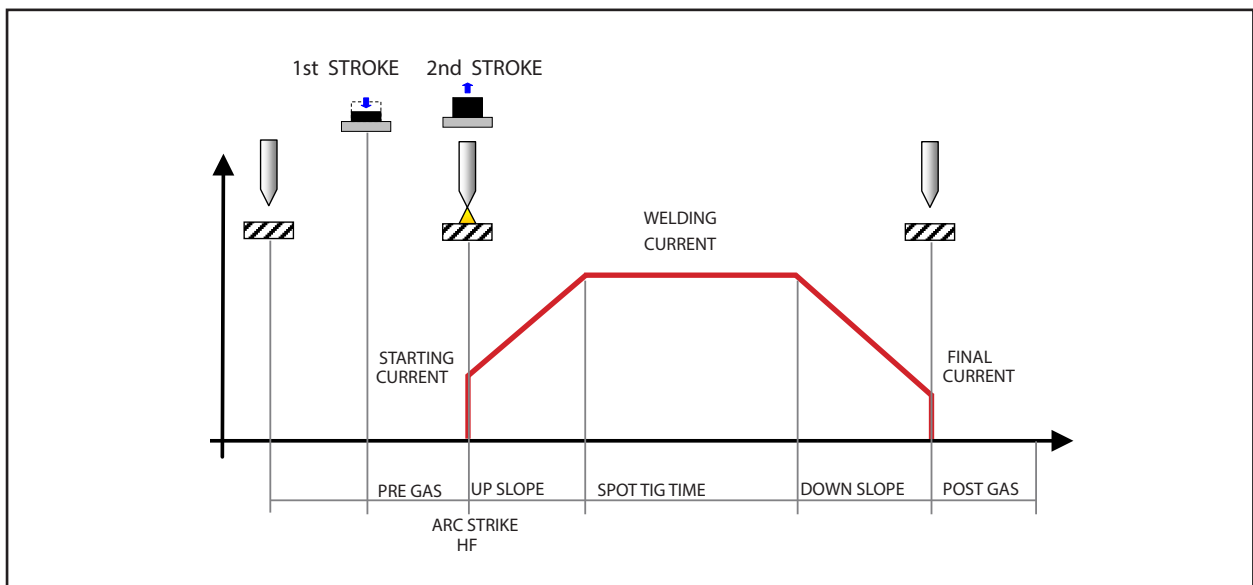

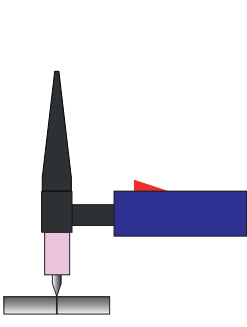
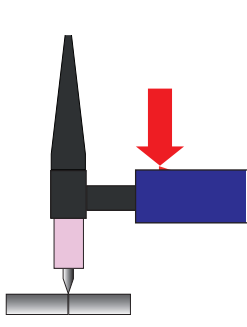
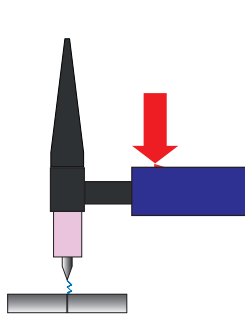
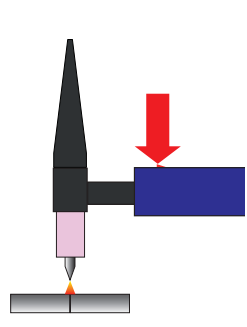
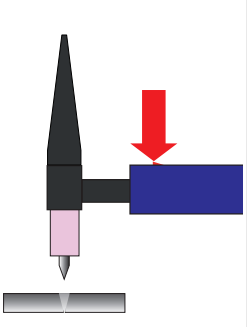
				
1. Position the torch with the electrode on the workpiece.	2. Press the torch trigger and keep it pressed.	3. Lift the torch slightly. As soon as the electrode is lifted then the HF ignition starts.	4. The arc ignites for a few hundredths of a second (time can be set up).	5. The result of this is a very precise, not oxidized welding spot without any plastic deformation of the sheet.

PROCEDURE WITH CONTINUOUS PRESSURE OF TORCH TRIGGER

- Bring the torch up to the work until the electrode tip is approximately 2 or 3 mm away.
- Press (1T) torch trigger.
- The arc strikes without contact with the workpiece and the voltage discharges (HF) cease automatically.
- The welding current reaches the preset value, by way of a up slope time, if programmed.
- The welding procedure continues, at the preset current, for the time set with the spot time parameter.
- The current reaches the end current value in the time set in the down slope time parameter.
- The arc is extinguished.
- Gas delivery continues for the time set in the post gas parameter.
- Touch the workpiece with the torch electrode.
- Slowly lift the torch to strike the arc.

The welding parameters are available in accordance with the selected welding mode and procedure. Certain parameters are available only after other parameters or functions of the unit have been enabled or set.















The table shows the settings required to enable each parameter.

LEGEND

- √: Always available
- 1: Available with the user interface reference active
- 2: Available with rC= on and remote controller connected
- 3: Available with HF= on
- 4: Not available with M.ta. active
- 5: Available with PUL.= Slo.

ENGLISH

Tab. 18 - Table showing enabled Welding Parameters

MENU ↓	MODE →													
	PROCEDURE →													
	PARAMETER ↓													
1°	WELDING CURRENT (MMA)	1												
1st	MAXIMUM RC CURRENT IN MMA MODE	2												
1°	HOT START	√												
1°	ARC FORCE	√												
1°	PRE GAS TIME		3	3	3	3	3	3	3	3	3	3	3	
1°	STARTING CURRENT		4	4	4	4	4	4	4	4	4	4	4	
1°	UP SLOPE TIME		4	4	4	4	4	4	4	4	4	4	4	
1°	WELDING CURRENT (TIG)		1	1	1	1	1	1	1	1	1	1	1	
1°	MAXIMUM PEDAL CURRENT IN TIG		2	2			2	2		2	2			
1°	SECOND WELDING CURRENT					√			√				√	
1°	BASE CURRENT						√	√	√	√	√	√	√	
1°	PEAK TIME						√	√	√	√	√	√	√	
1°	BASE TIME						5	5	5	5	5	5	5	
1°	PULSED CURRENT FREQUENCY						√	√	√	√	√	√	√	
1°	DOWN SLOPE TIME		4	4	4	4	4	4	4	4	4	4	4	
1°	FINAL CURRENT		4	4	4	4	4	4	4	4	4	4	4	
1°	POST GAS TIME		√	√	√	√	√	√	√	√	√	√	√	
2nd	ELECTRODE TYPE	√												
2nd	VRD	√												
2nd	LONG ARC VOLTAGE MMA	√												
2nd	REMOTE CONTROL ACTIVATION	√	√	√	√	√	√	√	√	√	√	√	√	
2nd	SPOT WELDING TIME			√				√			√			
2nd	HF ARC STRIKE ENABLE		√	√	√	√	√	√	√	√	√	√	√	
2nd	MINIMUM PEDAL CURRENT		2	2			2	2		2	2			
SPECIAL	Q-START		3		3	3	3		3	3				
SPECIAL	DYNAMIC ARC	√	√		√		√		√					
SPECIAL	MULTI TACK		3	3	3		3	3	3		3	3	3	

12 JOBS MANAGEMENT

Personalised welding settings, or JOBS, can be saved in memory locations and subsequently uploaded. Up to 50 JOBS can be saved (j01-j50).

JOBS can be managed only when the unit is not in welding mode.





The SETUP menu settings cannot be saved by means of the JOBS.

When a JOB is loaded and an UP/DOWN torch is installed, press the torch triggers to select the saved JOBS.

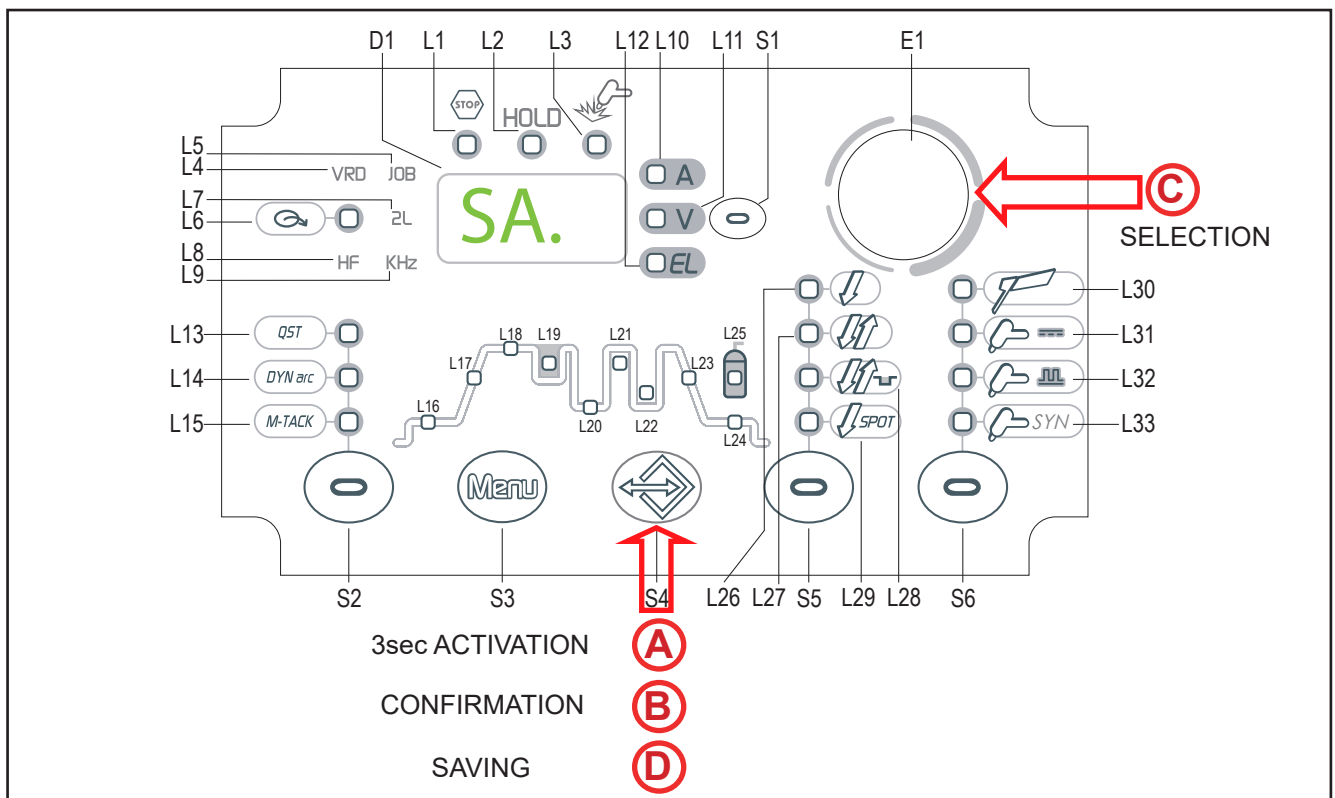
If there are no JOBS loaded, the UP/DOWN buttons on the torch serve to adjust the welding current.

12.1 SAVING A JOB



- | | |
|-------------------|--|
| <p>(A)</p> | <ul style="list-style-type: none"> Hold down the S4  button for 3 seconds to gain access to the JOB SAVE/DELETE menu. <ul style="list-style-type: none"> SA. : The message appears on the following displays D1. |
| <p>(B)</p> | <ul style="list-style-type: none"> Press the S4  button to confirm. <ul style="list-style-type: none"> S.xx : The message will appear on display D1. <ul style="list-style-type: none"> xx= number of the first free job. |
| <p>(C)</p> | <ul style="list-style-type: none"> Using the encoder E1 , select the desired job number. <ul style="list-style-type: none"> S.yy : The message will appear on display D1. On selecting a currently occupied memory location, the job number flashes. |
| <p>(D)</p> | <ul style="list-style-type: none"> Press the S4  button to save the JOB and exit the menu. If you confirm at this point, the new job will overwrite the previously saved settings. |

Press any button  (except **S4**) to exit without confirming.

12.2 DELETING A JOB

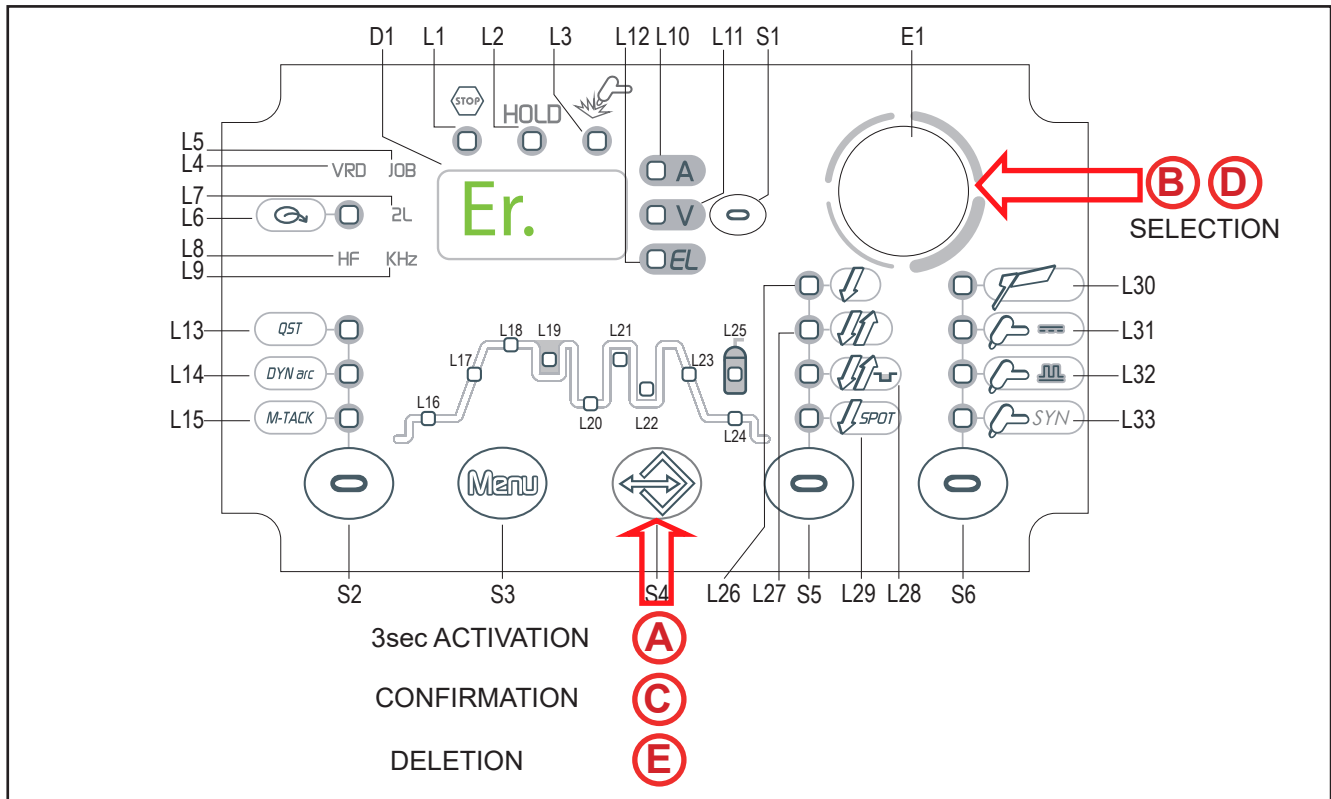

(A) ○ Hold down the **S4** button for 3 seconds to gain access to the JOB SAVE/DELETE menu.
● **SA.** : The message appears on the following displays **D1**.

(B) ○ Use the **encoder E1** , to select the following setting: **Er.**
- The message is shown on display **D1** only if there are saved JOBS.

(C) ○ Press the **S4** button to confirm.
● **E.xx** : The message will appear on display **D1**.
• xx= number of the last job used.



(D) ○ Use the **encoder E1** to select the number of the job to be deleted.

(E) ○ Press the **S4** button to cancel the JOB and quit the menu.

Press any button (except **S4**) to exit without confirming.

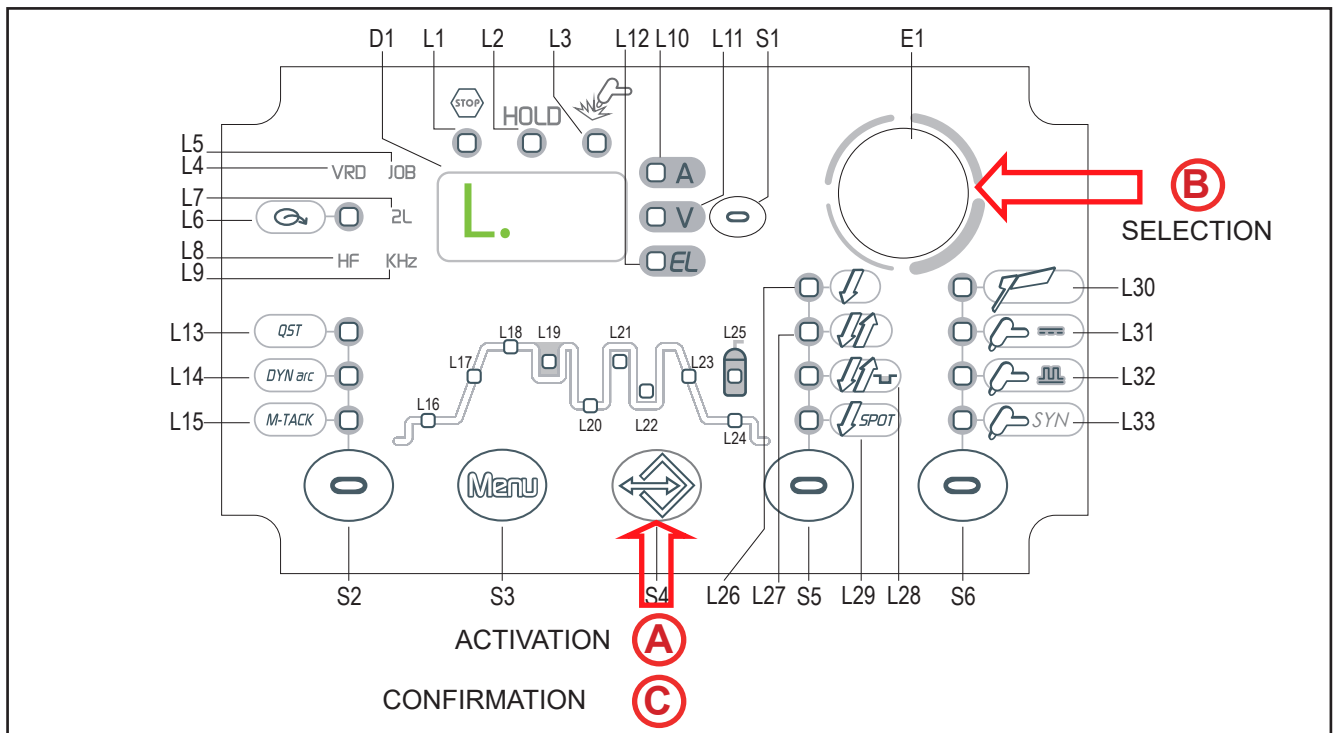
12.3 LOADING A JOB



- | | |
|------------|---|
| (A) | <ul style="list-style-type: none"> ○ Press and release the S4  button to activate the LOAD JOB menu. ● L.xx : Only after loading the job, the message will appear on display D1. <ul style="list-style-type: none"> • xx= number of the last job used. ● nO.J : If there are no saved jobs, the message will appear on display D1. |
| (B) | <ul style="list-style-type: none"> ○ Using the encoder E1 , select the job number to be loaded. |
| (C) | <ul style="list-style-type: none"> ○ Press the S4  button to load the JOB and exit from the menu. ● JOB The LED will illuminate. |





To quit the currently loaded JOB, change any setting on the power source user interface. Press any button  (except **S4**) to exit without confirming.

12.4 SELECTING JOBS USING THE TORCH BUTTONS



When an UP/DOWN torch is installed you can select the JOBs by using the buttons on the welding torch.

Select and upload one of the JOBs (e.g. J.06) on the power source user interface. Use the buttons on the welding torch to scroll the JOBs saved.

13 TECHNICAL DATA

Directives applied	Waste electrical and electronic equipment (WEEE)
	Electromagnetic compatibility (EMC)
	Low voltage (LVD)
	Restriction of the use of certain hazardous substances (RoHS)
Construction standards	EN 60974-1; EN 60974-3; EN 60974-10 Class A
Conformity markings	 Equipment compliant with European directives in force
	 suitable in an environment with increased hazard of electric shock
	 compliant with WEEE directive
	 Equipment compliant with RoHS directive

13.1 MULTI POWER 204T

Supply voltage	1 x 230 Va.c. ± 15 % / 50-60 Hz - 1 x 115 Va.c. ± 15 % / 50-60 Hz		
Mains protection	16 A Delayed - 32 A Delayed		
Zmax	Compliant with EN 61000-3-12 Hook-up not dependent on the supply network		
Dimensions (L x D x H)	400 x 160 x 260 mm		
Weight	9.8 kg		
Insulation class	H		
Protection rating	IP23S		
Cooling	AF: Air-over cooling (fan assisted)		
Maximum gas pressure	0,5 MPa (5 bar)		
Static characteristic	MMA	 Falling characteristic	
	TIG	 Falling characteristic	
Welding mode		MMA 230 Va.c. (115 Va.c.)	TIG 230 Va.c. (115 Va.c.)
Current and voltage adjustment range		10 A / 20.4 V - 150 A - 26.0 V (10 A / 20.4 V - 115 A - 24.6 V)	5 A / 10.2 V - 170 A - 16.8 V (10 A / 20.4 V - 115 A - 14.6 V)
Welding current / Working voltage	30% (40° C)	---	200 A -18.0 V (---)
	35% (40° C)	180 A -27.2 V (---)	---
	50% (40° C)	---	---
	60% (40° C)	130 A -25.2 V (110 A - 24.4 V)	140 A -15.6 V (---)
	100% (40° C)	120 A -24.8 V (105 A -24.2 V)	130 A -15.2 V (115 A -14.6 V)

Maximum input power	30% (40° C)	--- (---)	4.6 KVA - 4.3 KW (---)
	35% (40° C)	5.8 KVA - 5.6 KW (---)	---
	50% (40° C)	---	---
	60% (40° C)	4.0 KVA - 3.8 KW (3.3 KVA - 3.2 KW)	2.9 KVA - 2.6 KW (---)
	100 % (40° C)	3.6 KVA - 3.4 KW (3.1 KVA - 3.0 KW)	2.6 KVA - 2.4 KW (2.2 KVA - 2.1 KW)
Maximum input current	30% (40° C)	---	19.6 A (---)
	35% (40° C)	25.3 A (---)	---
	50% (40° C)	---	---
	60% (40° C)	17.3 A (28.2 A)	12.2 A (---)
	100 % (40° C)	15.4 A (27.0 A)	11.1 A (18.5 A)
Actual input current	30% (40° C)	---	10.7 A (---)
	35% (40° C)	15.0 A (---)	---
	50% (40° C)	---	---
	60% (40° C)	13.4 A (21.8 A)	9.5 A (---)
	100 % (40° C)	15.4 A (27.0 A)	11.1 A (18.5 A)
No-load voltage (U₀)		83 V	83 V
Reduced no-load voltage (U_r)		11 V	11 V
Rated HF peak voltage (U_p)	11.3 kV Arc striking device designed to work with manual guided torch.		
Power source efficiency	Efficiency (180A / 27,2V): 83%		
	No-Load condition power consumption (U ₁ = 230 Va.c.): 15 W		
Essential raw materials	According to the information provided by our suppliers, this product does not contain essential raw materials in quantities greater than 1g per component.		

ENGLISH

14 WIRING DIAGRAM

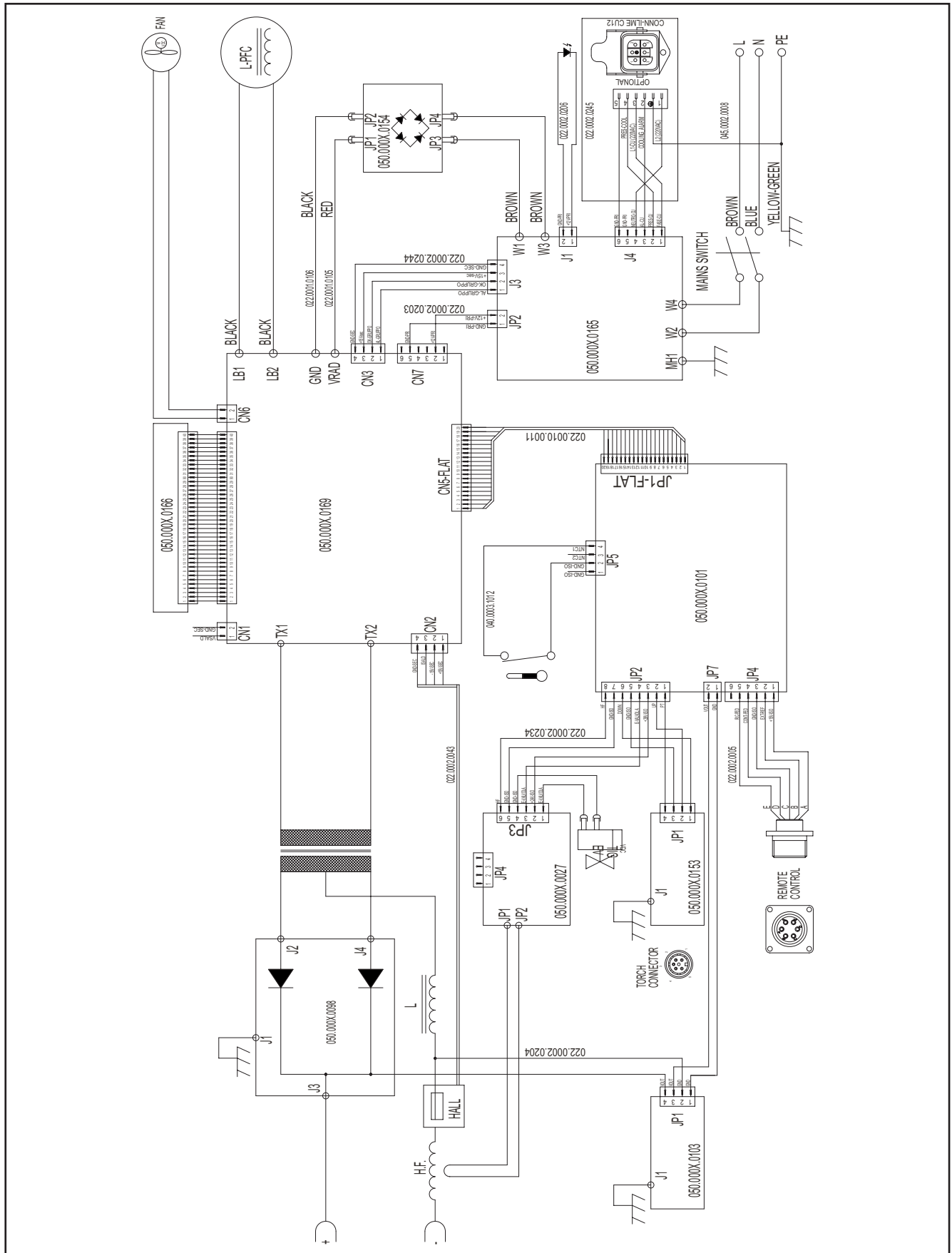

14.1 TORCH CONNECTOR (front panel)

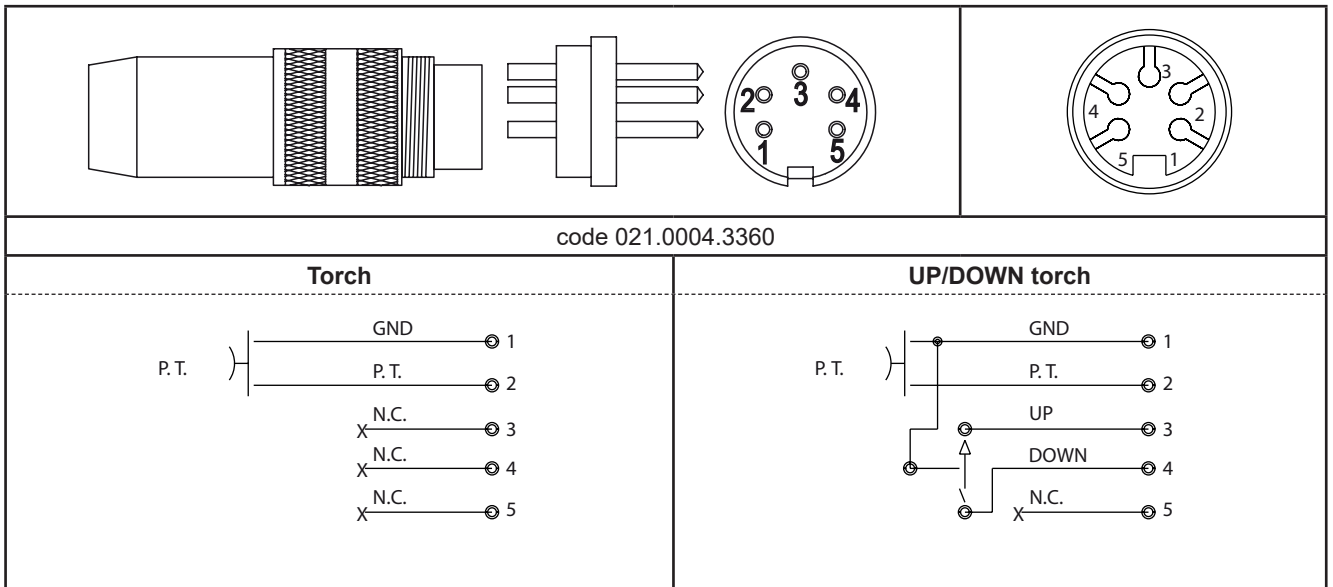

14.2 REMOTE CONTROL CONNECTOR (back panel)

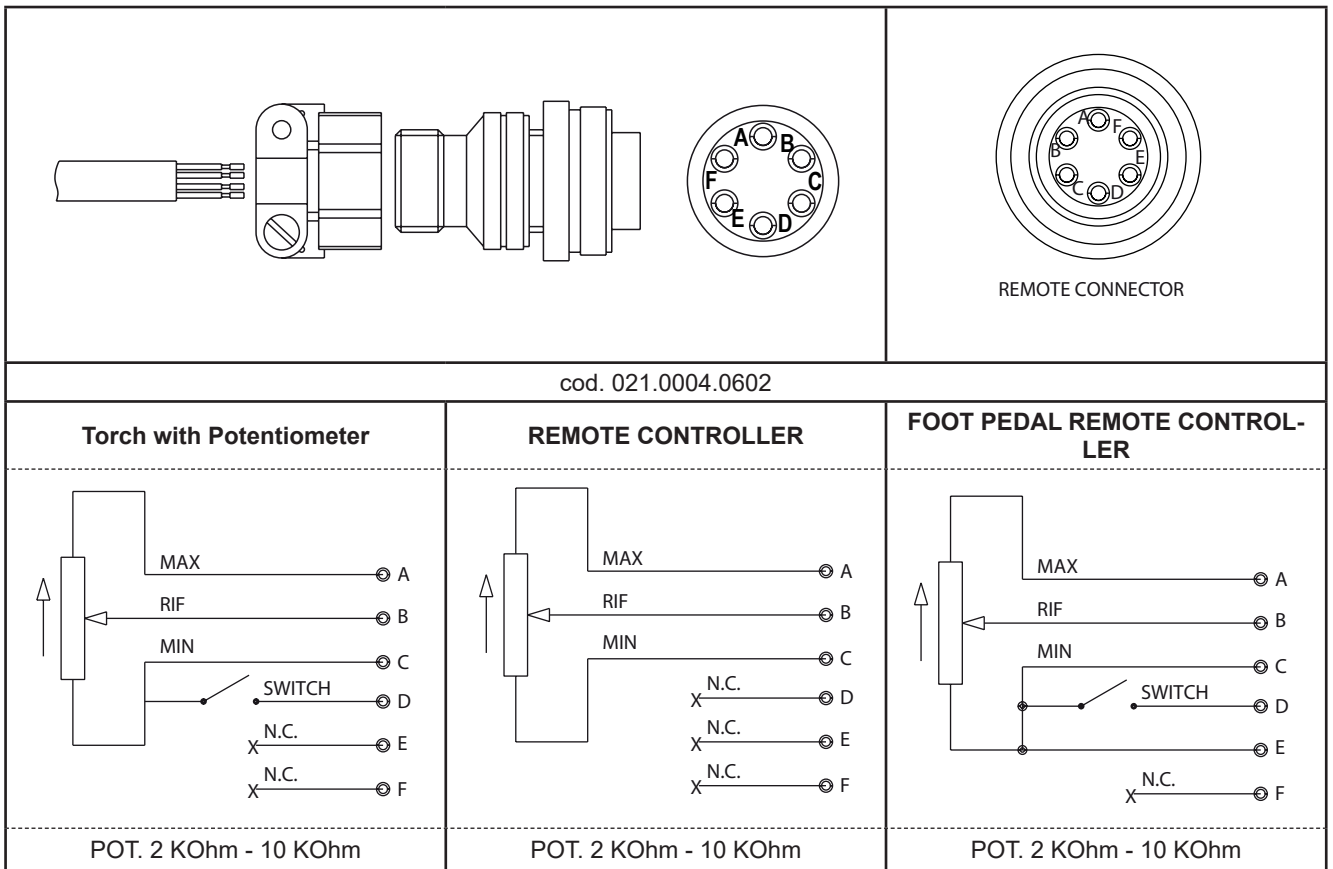

ENGLISH

15 SPARES

15.1 MULTI POWER 204T

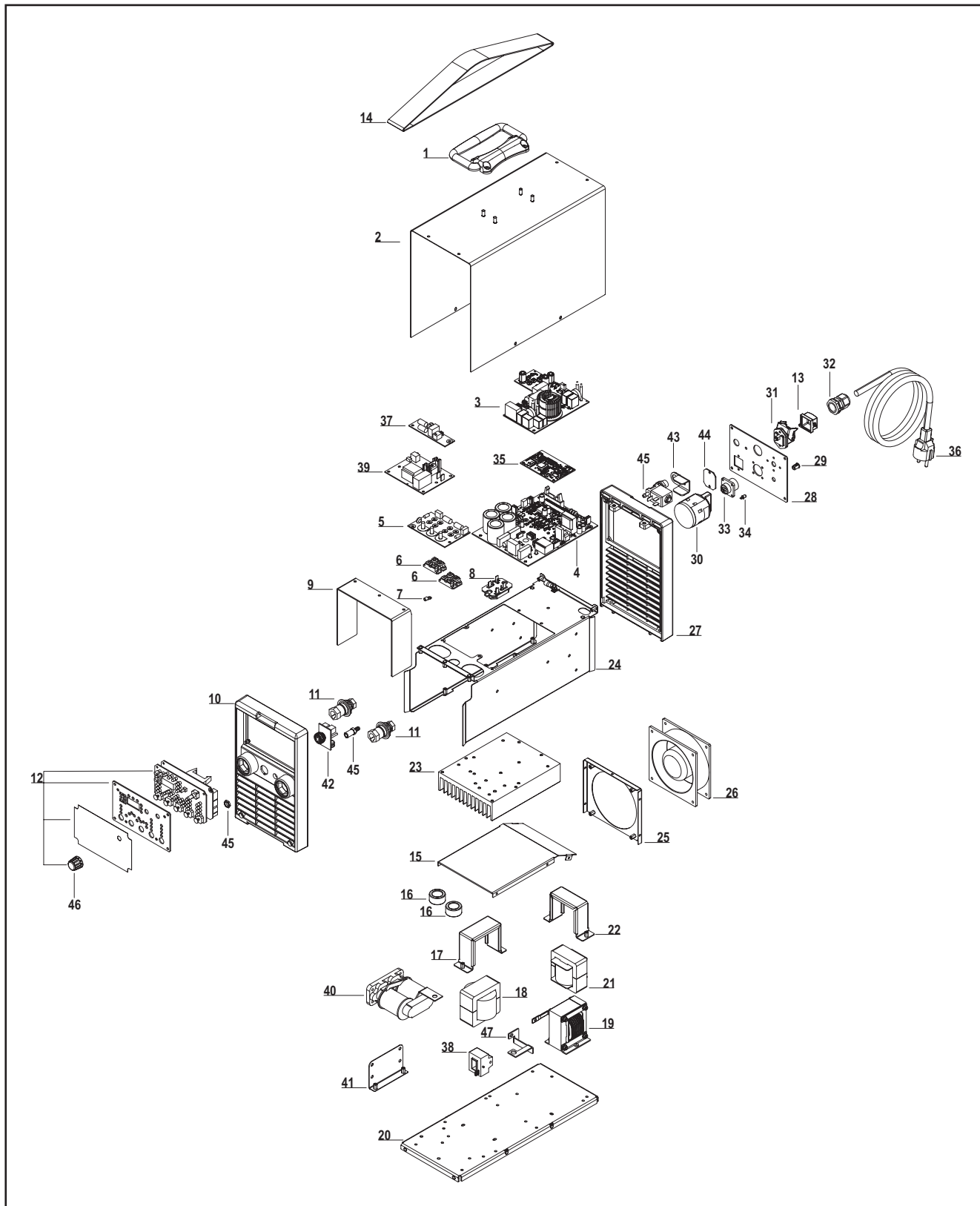

No.	CODE	DESCRIPTION
1	011.0006.0031	HANDLE
2	011.0000.0121	UPPER COVER
3	050.0002.0165	LINE FILTER BOARD
4	050.0003.0169	COMPLETE POWER BOARD (with board .0166)
5	050.0002.0098	SNUBBER BOARD
6	032.0002.2403	ISOTOP DIODE
7	040.0003.1008	TERMAL SWITCH
8	050.0001.0154	PRIMARY RECTIFIER BOARD
9	046.0004.0009	TUNNEL PLASTIC INSULATION
10	010.0006.0043	COMPLETE FRONT PLASTIC PANEL
11	021.0001.0260	FIXED SOCKET 400A
12	050.5031.0000	COMPLETE LOGIC FRONT PANEL
13	021.0013.0007	ILME CONNECTOR CAP (OPTIONAL WITH KIT CU-204T)
14	005.0001.0004	BELT
15	011.0003.0054	VENTILATION SHROUD
16	043.0002.0621	OUTPUT TOROIDAL FILTER
17	011.0003.0057	BOOST INDUCTANCE SUPPORT
18	044.0004.0017	BOOST INDUCTANCE
19	044.0004.0031	OUTPUT INDUCTANCE
20	011.0003.0051	LOWER COVER
21	042.0003.0043	POWER TRANSFORMER
22	011.0003.0056	TRANSFORMER SUPPORT
23	015.0001.0018	HEAT SINK
24	011.0003.0052	TUNNEL HOUSING
25	011.0003.0053	FAN SUPPORT
26	003.0002.0017	FAN
27	010.0006.0042	COMPLETE REAR PLASTIC PANEL
28	013.0014.0400	REAR PANEL
29	016.4107.0001	LED HOLDER
30	040.0001.0011	TWO-POLE SWITCH
31	022.0002.0245	C.U. POWER SUPPLY WIRING (OPTIONAL WITH KIT CU-204T)
32	045.0000.0014	CABLE CLAMP
33	022.0002.0005	REMOTE CONTRO WIRING
34	022.0002.0206	LED WIRING
35	050.0002.0166	INVERTER + CONTROL BOOST BOARD
36	045.0002.0008	NEOPRENE SUPPLY CABLE
37	050.0002.0103	OUTPUT FILTER BOARD
38	041.0004.0302	CURRENT SENSOR
39	050.0003.0027	HF BOARD
40	010.0002.0004	COMPLETE HF TRANSFORMER
41	011.0003.0058	HF SUPPORT PLATE
42	050.0002.0153	TORCH CONNECTOR
43	011.0002.0018	SOLENOID VALVE PLATE
44	011.0016.0125	C.U. CONNECTION COVER PLATE
45	010.0001.0010	COMPLETE SOLENOID VALVE
46	014.0002.0002	KNOB WITH CUP WITHOUT INDICATOR
47	045.0006.0123	CURRENT SENSOR BRACKET

15.2 TORCH CONNECTORS COMPLETE KIT

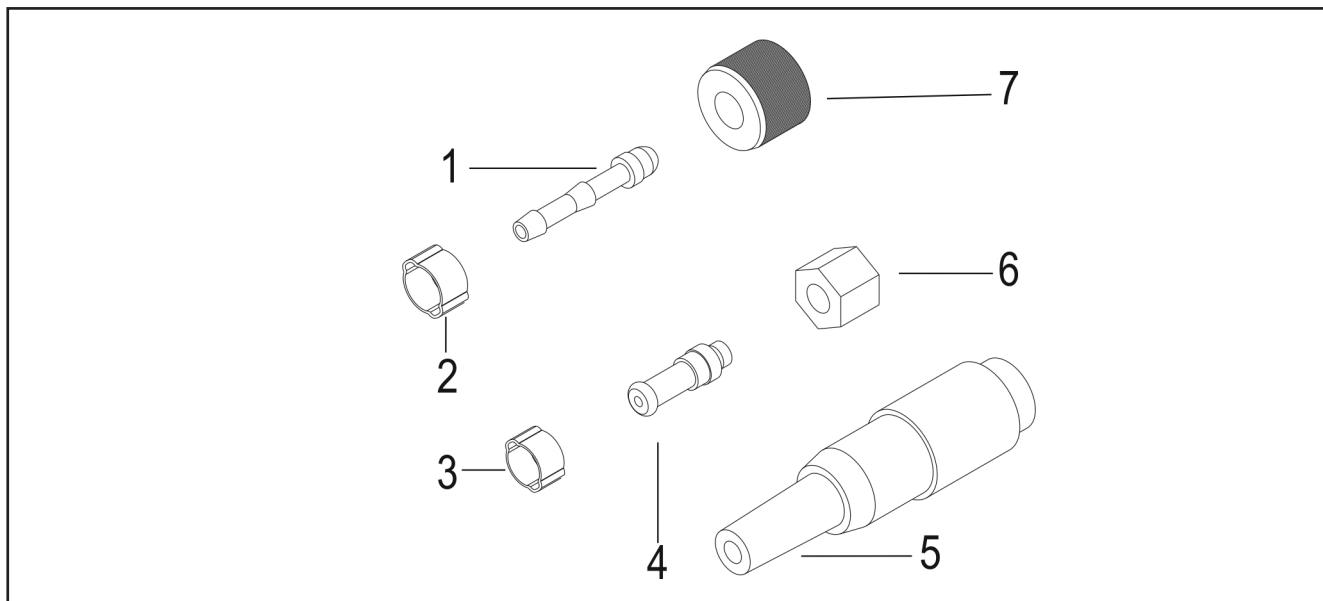

No.	CODE	DESCRIPTION
	021.0000.0001	TORCH CONNECTORS COMPLETE KIT
1	016.5001.0822	SLEEVE HOSE ADAPTOR 1/4
2	016.0007.0001	HOSE CLAMPS Ø=11-13
3	016.0007.0709	HOSE CLAMP Ø=07-09
4	016.5001.0821	SLEEVE HOSE ADAPTER FOR RUBBER HOSE M10
5	021.0004.3360	AMPHT3360-001 M/5V. VOL. CONNECTOR
6	016.5001.1311	NUT M10
7	016.5001.0823	NUT 1/4





WELD THE WORLD

www.weco.it

