



WELD THE WORLD

**CU-07C**  
**CU-07C-HP**

# Instruction Manual







---

## INDEX

<b>1</b>	<b>INTRODUCTION.....</b>	<b>4</b>
1.1	INTRODUCTION.....	4
<b>2</b>	<b>INSTALLATION .....</b>	<b>5</b>
2.1	FRONT PANEL .....	5
2.2	ASSEMBLY WITH THE WELDING POWER SOURCE.....	6
<b>3</b>	<b>TECHNICAL DATA .....</b>	<b>8</b>
3.1	CU-07C .....	8
3.2	CU-07C-HP .....	8
<b>4</b>	<b>SPARE PARTS .....</b>	<b>10</b>
4.1	COUPLINGS KIT ALREADY ASSEMBLED .....	13
<b>5</b>	<b>ELECTRICAL DIAGRAM .....</b>	<b>14</b>

# 1 INTRODUCTION

 	<b>IMPORTANT!</b>
<p><i>This handbook must be consigned to the user prior to installation and commissioning of the unit. Read the “General prescriptions for use” handbook supplied separately from this manual before installing and commissioning the unit.</i></p> <p><i>The meaning of the symbols in this manual and the associated precautionary information are given in the “general prescriptions for use”.</i></p> <p><i>If the “general prescriptions of use” are not present, it is mandatory to request a replacement copy from the manufacturer or from your dealer.</i></p> <p><i>Retain these documents for future consultation.</i></p>	

## LEGENDA

	<b>DANGER!</b>
<p><i>This pictogram warns of danger of death or serious injury.</i></p>	
	<b>WARNING!</b>
<p><i>This pictogram warns of a risk of injury or damage to property.</i></p>	
	<b>CAUTION!</b>
<p><i>This pictogram warns of a potentially hazardous situation.</i></p>	
	<b>INFORMATION!</b>
<p><i>This pictogram gives important information concerning the execution of the relevant operations.</i></p>	

## NOTES

The figures in this manual are purely guideline and the images may contain differences with respect to the actual equipment to which they refer.

### 1.1 INTRODUCTION

The cooling unit CU-07C/ CU-07C-HP can be connected to the generator, allowing the liquid cooling of the TIG torch.

## 2 INSTALLATION

### 2.1 FRONT PANEL

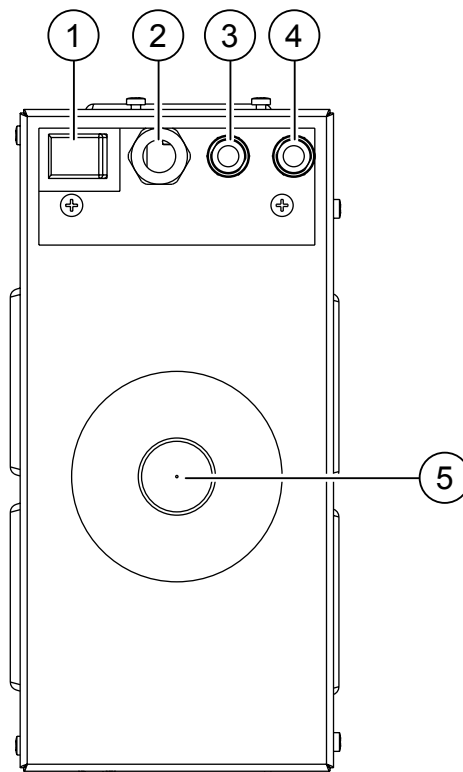





1. Switch for switching on and off.
2. Power cable.
  - Total length (including internal part): 0,95 m
  - Number and cross section of wires: 5 x 1 mm<sup>2</sup>
  - Power plug type: ILME 16 A 230 / 400 Va.c.
3. Connector for coolant hose:  
cooler → power source
4. Connector for coolant hose:  
power source → cooler
5. Inlet for jerrycan filling.

## 2.2 ASSEMBLY WITH THE WELDING POWER SOURCE

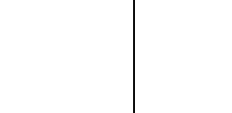

**DANGER!**  
**Lifting and positioning**

*Read the warnings highlighted by the following symbols in the “General prescriptions for use”.*



1. Set the welding power source ON/OFF switch to “O” (unit de-energized).
2. Fasten the welding power source support bracket to the cooler.
3. Mount the cooler in the relevant location.
4. Screw the cooler fixing bracket to the welding power source chassis using the supplied screws.
5. Screw the base of the cooler to the unit base using the supplied screws.
6. Connect the plug of the cooler power cable to the cooler power socket on the rear panel of the welding power source.
7. Attach the coolant hoses to the relevant connectors on the cooler and on the power source rear panel.
8. Plug the power cable plug into a mains socket outlet.
9. Set the welding power source ON/OFF switch to “I” to switch on the unit.
10. Set the cooler ON/OFF switch to “I” (unit powered).

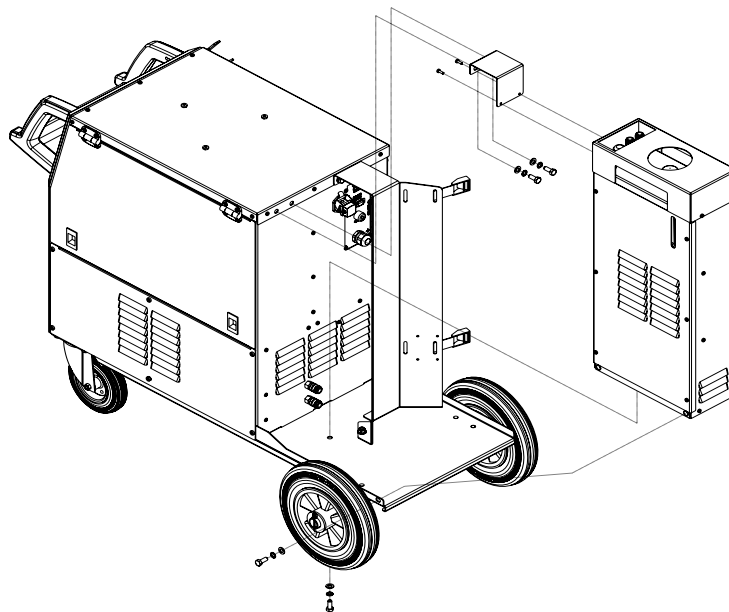







## **WARNING!**

***Periodically checking the level of the liquid in the indicator on the side of the cooling unit.  
Be careful when choosing the cooling liquid: it must not be an electricity conductor.  
Do not use polypropylene liquids because they damage the seals and generate incrustations.  
Read the warnings highlighted by the following symbols in the "General prescriptions for use".***



### 3 TECHNICAL DATA

<b>Directives applied</b>	Waste electrical and electronic equipment (WEEE)
	Electromagnetic compatibility (EMC)
	Low voltage (LVD)
	Restriction of the use of certain hazardous substances (RoHS)
<b>Construction standards</b>	EN 60974-2; EN 60974-10 Class A
<b>Conformity markings</b>	 Equipment compliant with European directives in force
	 Suitable in an environment with increased hazard of electric shock
	 Compliant with WEEE directive
	 Equipment compliant with RoHS directive

#### 3.1 CU-07C

<b>Supply voltage</b>	1 x 230 V~ ± 15 % / 50-60 Hz
<b>Dimensions ( D x L x H )</b>	142 x 280 x 620 mm
<b>Weight</b>	10.0 kg (13.0 kg with liquid)
<b>Tank capacity</b>	3.0 l
<b>Protection rating</b>	IP23
<b>Maximum input current (A)</b>	1.3 A (50 Hz) - 1.53 A (60 Hz)
<b>Cooling power</b>	1.1 kW (1l/min) - 1.4 kW (max. l/min)
<b>Maximum pressure</b>	0.33 MPa (50 Hz)–0.44 MPa (60 Hz)

#### 3.2 CU-07C-HP

<b>Supply voltage</b>	1 x 230 V~ ± 15 % / 50-60 Hz
<b>Dimensions ( D x L x H )</b>	142 x 280 x 620 mm
<b>Weight</b>	10.0 kg (13.0 kg with liquid)
<b>Tank capacity</b>	3.0 l
<b>Protection rating</b>	IP23
<b>Maximum input current (A)</b>	1.5 A (50 Hz) - 1.78 A (60 Hz)
<b>Cooling power</b>	1.1 kW (1l/min) - 1.4 kW (max. l/min)
<b>Maximum pressure</b>	0.41 MPa (50 Hz) - 0.51 MPa (60 Hz)



The technical characteristics of the antifreeze liquid supplied with this appliance are found below:

<b>Base</b>	Refrigerants polymers with low pour point
<b>Appearance</b>	Liquid
<b>Color</b>	Colorless
<b>Odor</b>	Odorless
<b>Specific weight</b>	1.030 g/cm <sup>3</sup>
<b>Viscosity</b>	< 100 cP
<b>pH</b>	7 / 8
<b>Refractive index</b>	1.369 nD (20 °C)
<b>Boiling point</b>	102 °C
<b>Specific heat</b>	3.9 kJ/kg K
<b>Thermal conductivity</b>	0.45 W/m k (25 °C)
<b>Electrical conductivity</b>	2.3 mS/cm (20 °C)
<b>Dissolved chloridea</b>	< 2 ppm
<b>Dissolved sulfides</b>	< 2 ppm
<b>Hardness</b>	< 0.1 mol/m <sup>3</sup> (Ca <sup>++</sup> , Mg <sup>++</sup> )
<b>Biodegradability</b>	Complete
<b>Foaming power</b>	No
<b>Solubility</b>	Soluble in water

## 4 SPARE PARTS

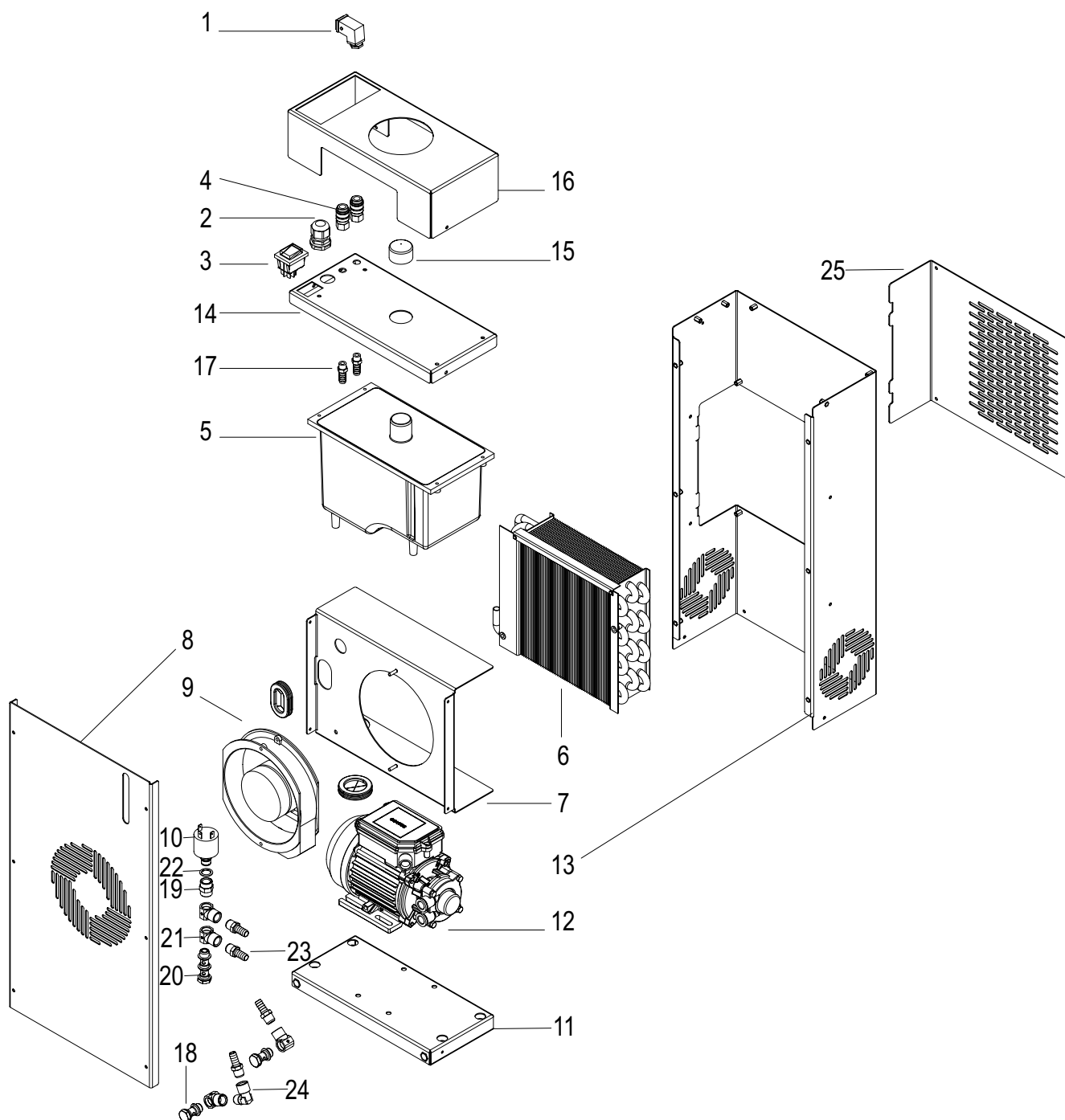

N°	CODE	DESCRIPTION
1	022.0002.0082	POWER SUPPLY CABLE
2	045.0000.0014	CABLE CLAMP
3	040.0001.0004	BI-POLE SWITCH
4	018.0002.0004	FLUIDS, FEMALE QUICK FITTING
5	003.0003.0009	TANK
6	003.0003.0014	RADIATOR
7	011.0012.0055	VENTILATION SHROUD
8	011.0012.0048	FRONT PLATE
9	003.0002.0016	FAN
10	017.0006.0007	PRESSURE SWITCH
11	011.0012.0051	PUMP SUPPORT
12	003.0004.0006	PUMP CU-07C
12	003.0004.0040	PUMP CU-07C-HP
13	011.0012.0049	REAR PLATE
14	011.0012.0054	UPPER COVER
15	003.0003.0011	CAP
16	011.0012.0056	GUARD SAFETY KIT
17	016.5001.3041	SLEEVE HOSE ADAPTER FOR RUBBER HOSE Ø= 10 mm F= 1/8 M
18	017.0003.0021	HOLLOW BOLT M= 1/4
19	017.0003.0056	F= 1/4 - M= 1/4 NIPPLE CONNECTOR
20	017.0003.0022	DOUBLE HOLLOW BOLT M= 1/4
21	017.0003.0024	HYDRAULIC SWIVEL JOINT LF= 1/4
22	016.1001.1001	WASHER 1/4 GAS NYLON
23	016.5001.3042	SLEEVE HOSE ADAPTER FOR RUBBER HOSE d= 10 mm F= 1/4 M
24	017.0003.0027	90° F= 1/4 - M= 1/4 NIPPLE CONNECTOR
25	011.0012.0050	FAN GRILL PLATE

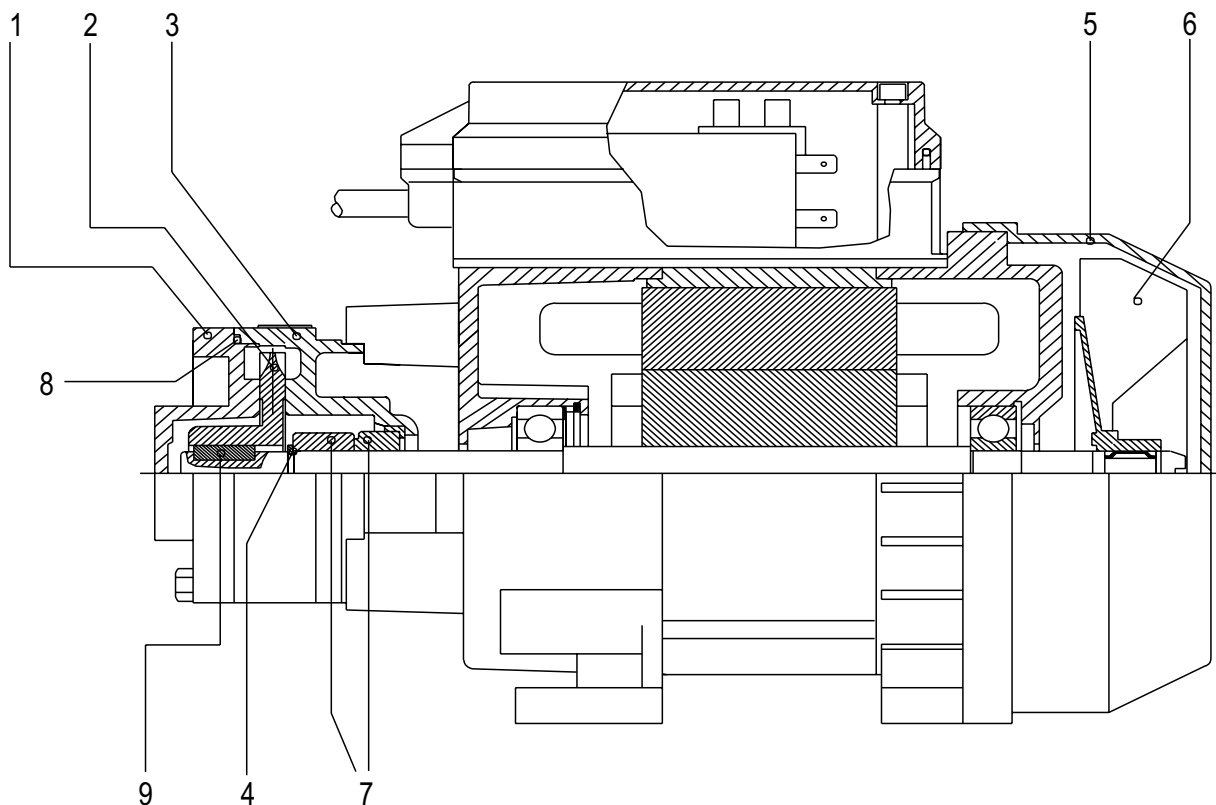

N°	CODE	DESCRIPTION
1	003.0004.0017	PUMP BODY ¼ GAS
2	003.0004.0018	IMPELLER
3	003.0004.0019	SEAL BODY
4	003.0004.0020	SEAL SEEGER
5	003.0004.0008	COVER FAN
6	003.0004.0007	FAN
7	003.0004.0021	MECHANICAL COMPLETE SEAL
8	003.0004.0023	BODY O-RING
9	003.0004.0022	SHAFT KEY

#### 4.1 COUPLINGS KIT ALREADY ASSEMBLED

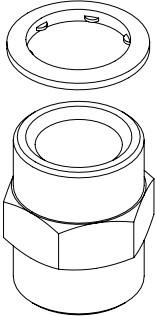
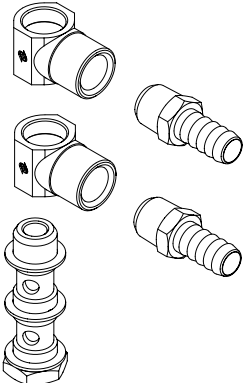
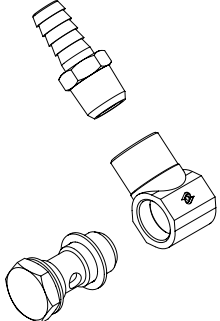
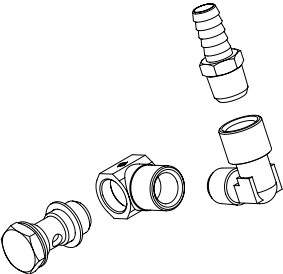
N°	CODE	DESCRIPTION
	010.0000.0067	PRESSURE SWITCH CONNECTOR KIT
	010.0000.0069	PRESSURE SWITCH PIPE DOUBLE CONNECTOR KIT
	010.0000.0070	PUMP UPPER CONNECTION KIT (A)
	010.0000.0071	PUMP LOWER CONNECTION KIT (B)

## 5 ELECTRICAL DIAGRAM

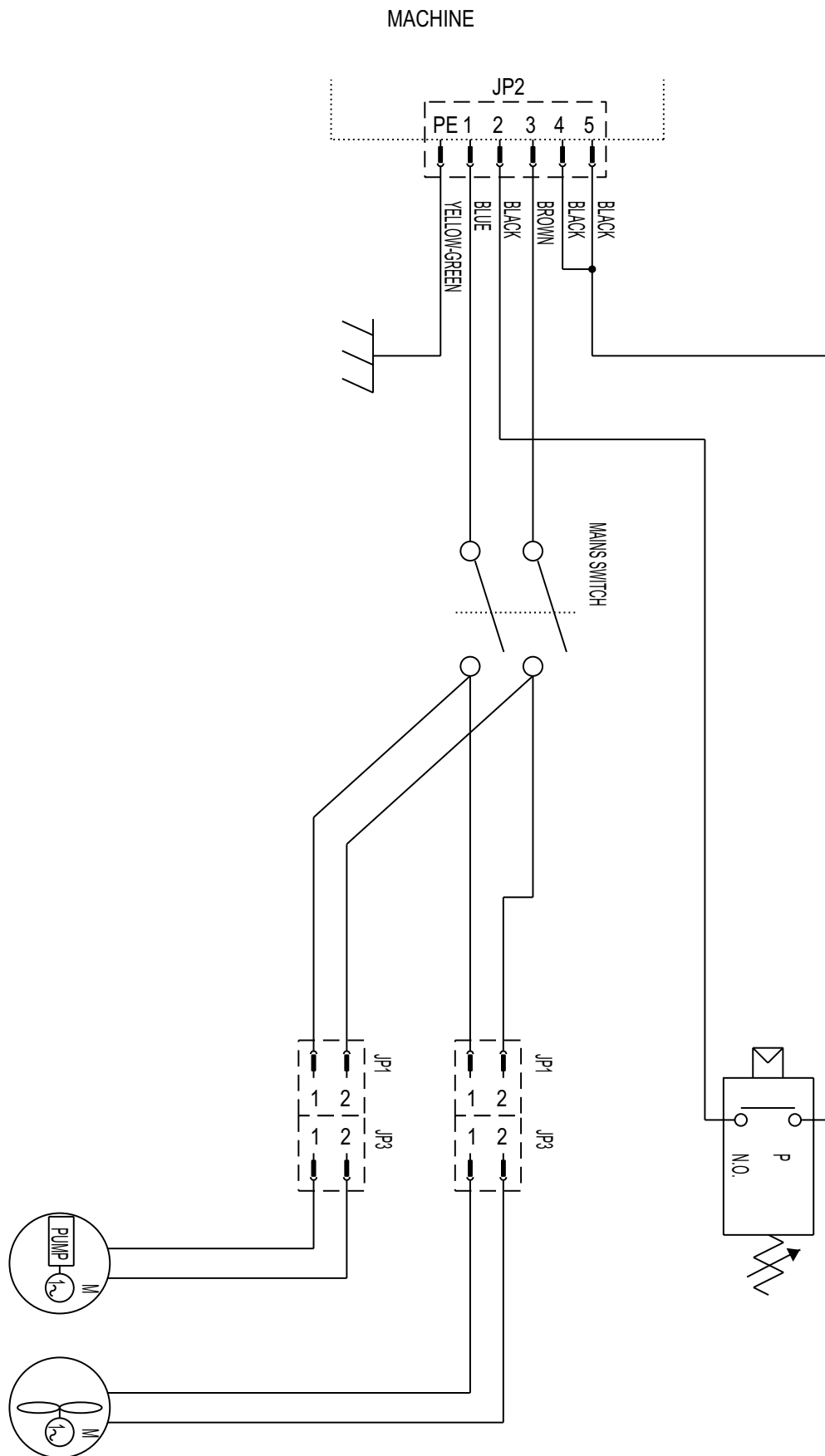





**WELD THE WORLD**

[www.weco.it](http://www.weco.it)

